

Serial Number

**QT
3.0L
30kW**

Model: 005219-0

**STANDBY GENERATOR
OWNER'S MANUAL**

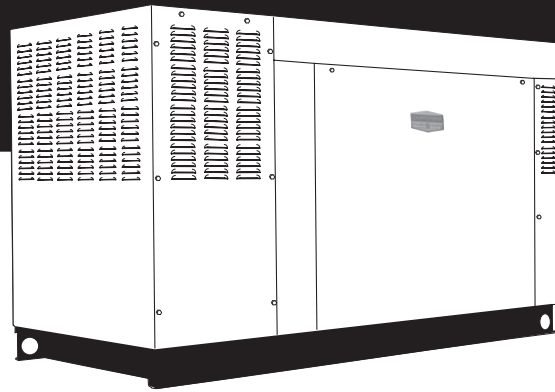

A new standard of reliability



⚠ Not intended for use in critical life support applications. ⚠

— ⚠ **CAUTION** ⚠ —

**ONLY QUALIFIED ELECTRICIANS OR CONTRACTORS SHOULD ATTEMPT INSTALLATION!
DEADLY EXHAUST FUMES. OUTDOOR INSTALLATION ONLY!**

This manual should remain with the unit.

GROUP A

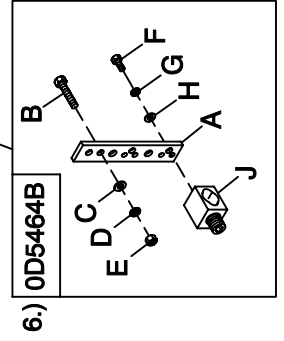
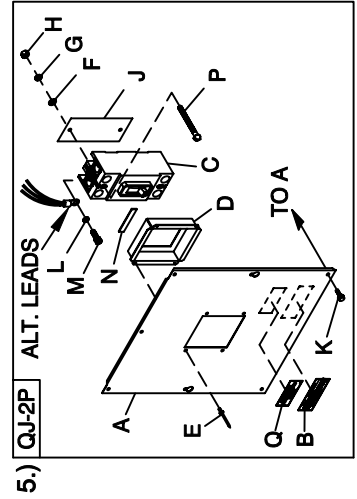
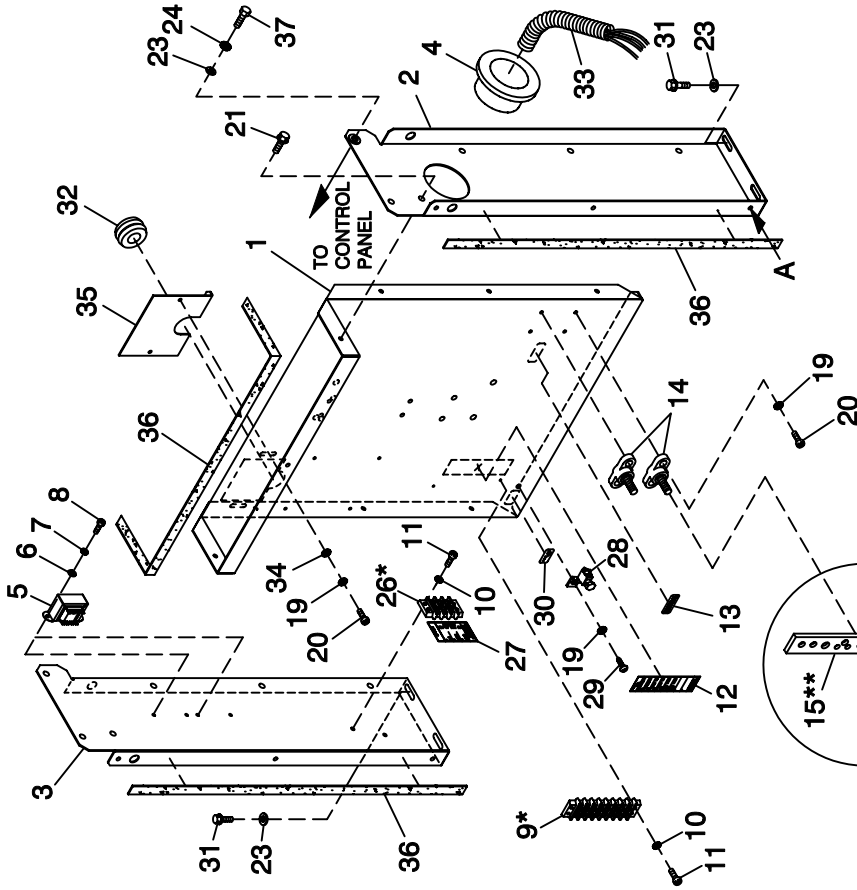
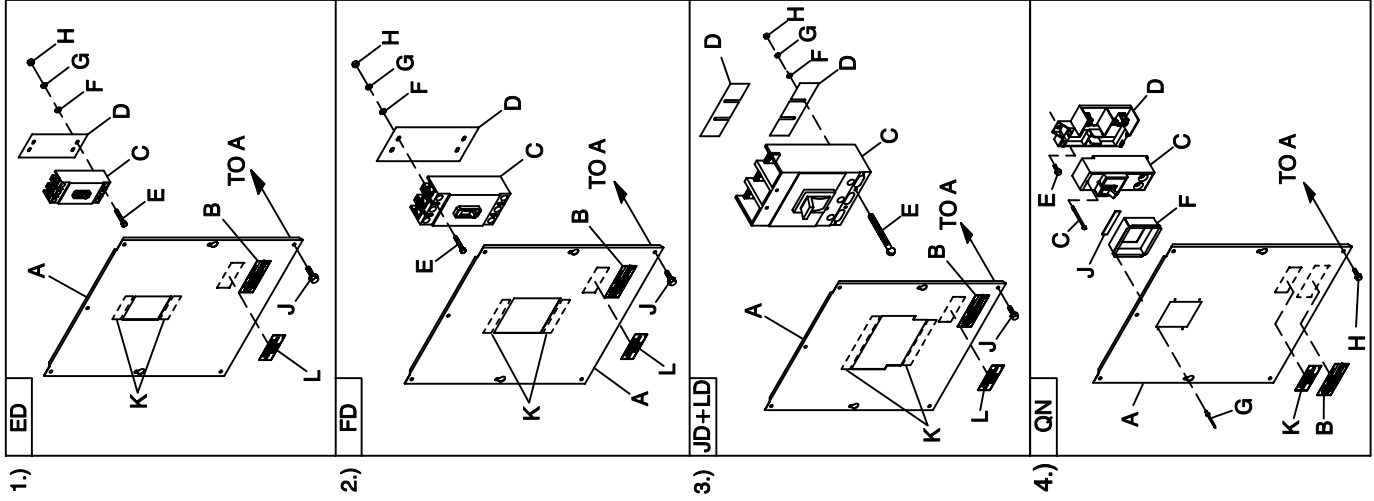

EXPLODED VIEW:
CPL C2 & C4 FLEX HSB
DRAWING #: 0F3391D

**EXPLODED VIEW: CPL C2 & C4 FLEX HSB
DRAWING #: 0F3391D**

GROUP A

APPLICABLE TO:

ITEM	PART #	QTY.	DESCRIPTION
1	0F3137	1	PAN CB CONN BOX
2	0F3188	1	STAND RH CONTROL
3	0F3189	1	STAND LH CONTROL
4	023484N	1	BUSHING SNAP SB-2.5-31
5 ***	0F6366B	1/2	XFMR DUAL 120V/16V (FOR 120/240V & 277/480V UNITS)
	0F6366A	1	XFMR DUAL 104V/16V (FOR 120/208V UNITS)
6 ***	043180	2/4	WASHER FLAT M4
7 ***	022264	2/4	WASHER LOCK #8-M4
8 ***	0C3990	2/4	SCREW PHTT M4-0.7 X 10 ZYC
9 *	057701	REF	BLOCK TERM 20A 8 X 6 X 1100V
10	022155	4	WASHER LOCK #6
11	0C2428	4	SCREW PHTT #6-32 X 1/2 ZYC
12	0F3824	1	DECAL UTIL SENSE/CUST CONN
13	0A9457	1	DECAL NEUTRAL
14	057073	2	JUNCTION BLOCK 3/8-16
15 **	0D5466	REF	BUS BAR NEUTRAL BLOCK 390
16 **	0A7822	REF	LUG SLDLSS 600/250-1/0 X 1/4-28
17	022237	2	WASHER LOCK 3/8
18	022241	2	NUT HEX 3/8-16 STEEL
19	049226	7	WASHER LOCK M5
20	0C2266	6	SCREW PHTT M5-0.8 X 16 ZYC
21	0C2454	8	SCREW THF M6-1 X 16 N WA Z/J5
23	022473	8	WASHER FLAT 1/4-M6 ZINC
24	022097	4	WASHER LOCK M6-1/4
26 *	0D4698	REF	BLOCK TERM 20A 6 X 3 X 1100V
27	0F4464	1	DECAL CUST CONN 120V UTILITY
28	025433	1	LUG SLDLSS #6-14 X 13/64 CU
29	024469	1	SCREW HHTT #10-32 X 3/8 CZ
30	067210A	1	DECAL GROUND LUG
31	0D6029	4	SCREW HHTT M6-1.0 X 16 ZYC
32	081008	1	GROMMET 1.25 X .25 X .75
33	077043J	1	CONDUIT FLEX 2.0" ID (36" LG)
34	051713	2	WASHER FLAT M5
35	0F6156	1	PLATE WIRE SNGL GALV
36	029289	1	TAPE ELEC 1/2 FOAM (AS REQ'D)
37	047411	4	SCREW HHC M6-1.0 X 16 G8.8
38 ****	064153B	2	WIRE JUMPER TRANSFORMER (NOT SHOWN)
1)			UL CIRCUIT BREAKER (ED)
A	0F3328	1	COVER ED CB SHORT STND
B	065469	1	DECAL DANGER HIGH VOLTAGE
C	0D5552	1	CB 0050A 3P 480V S ED4 LL
	0D5554	-	CB 0070A 3P 480V S ED4 LL
	0D5556	-	CB 0090A 3P 480V S ED4 LL
	0D9693	-	CB 0125A 3P 480V S ED4 LL
D	0F0492	1	INSULATOR CB S (ED-3P)
E	048927	4	SCREW RHM #10-32 X 4-1/2
F	023897	4	WASHER FLAT #10 ZINC
G	022152	4	WASHER LOCK #10
H	022158	4	NUT HEX #10-32 STEEL
J	0C2454	7	SCREW THF M6-1 X 16 N WA Z/J5
K	029289	1	TAPE ELEC 1/2 FOAM (AS REQ'D)
L	0F1733	1	DECAL CUSTOMER CONNECT INSIDE
2)			UL CIRCUIT BREAKER (FD)
A	0F3138	1	COVER CB CONN BOX
B	065469	1	DECAL DANGER HIGH VOLTAGE
C	0D5572	1	CB 0150A 3P 600V S FD6 LL
	0D5573	-	CB 0175A 3P 600V S FD6 LL
	0D5574	-	CB 0200A 3P 600V S FD6 LL
	0D5575	-	CB 0225A 3P 600V S FD6 LL
	0D5576	-	CB 0250A 3P 600V S FD6 LL
D	0F0199	1	INSULATOR CB FD FRAME 30MIL
E	081320	4	SCREW SHC 1/4-20 X 4.5 G8.8 NZ
F	022473	4	WASHER FLAT 1/4-M6 ZINC
G	022097	4	WASHER LOCK M6-1/4
H	022127	4	NUT HEX 1/4-20 STEEL
J	0C2454	7	SCREW THF M6-1 X 16 N WA Z/J5
K	029289	1	TAPE ELEC 1/2 FOAM (AS REQ'D)
L	0F1733	1	DECAL CUSTOMER CONNECT INSIDE
3)			UL CIRCUIT BREAKER (JD+LD)
A	0F3329	1	COVER JD/LD CB SHRT STAND

ITEM	PART #	QTY.	DESCRIPTION
B	065469	1	DECAL DANGER HIGH VOLTAGE
C	0D5577	1	CB 0300A 3P 600V S JD6 LL
D	0F2353	2	INSULATOR CIRCUIT BR. JD/LD
E	022770	4	SCREW RHM 1/4-20 X 3
F	022473	4	WASHER FLAT 1/4-M6 ZINC
G	022097	4	WASHER LOCK M6-1/4
H	022127	4	NUT HEX 1/4-20 STEEL
J	0C2454	7	SCREW THF M6-1 X 16 N WA Z/J5
K	029289	1	TAPE ELEC 1/2 FOAM (AS REQ'D)
L	0F1733	1	DECAL CUSTOMER CONNECT INSIDE
4)			UL CIRCUIT BREAKER (QN)
A	0F8135	1	COVER QN FRM CB
B	065469	1	DECAL, DANGER HIGH VOLTAGE
C	0E7283	-	CB 0150A 2P 240V S QN2 LL
	0E7284	-	CB 0175A 2P S QN2 LL 240V
D	0E3664	1	BASE, QN CIRCUIT BREAKER
E	074908	2	SCREW HHTT M5-0.8 X 10 BP
F	0F8140	1	COVER QN CB DISH
G	036261	4	RIVET POP .125 X .275 SS
H	0C2454	7	SCREW THF M6-1X16 N WA Z/J5
J	029289	1	TAPE ELEC 1/2 FOAM (AS REQ'D)
K	0F1733	1	DECAL CUSTOMER CONNECT INSIDE
5)			UL CIRCUIT BREAKER (QJ-2P)
A	0F8137	1	COVER QJ 2P FRM CB
B	065469	1	DECAL, DANGER HIGH VOLTAGE
C	0E7994	-	CB 0225A 240V 2P S QJ22
D	0F8136	1	COVER QJ 2P CB DISH
E	036261	4	RIVET POP .125 X .275 SS
F	022473	2	WASHER FLAT 1/4-M6 ZINC
G	022097	2	WASHER LOCK M6-1/4
H	022127	2	NUT HEX 1/4-20 STEEL
J	0F8139	1	INSUL CB 2P QJ
K	0C2454	7	SCREW THF M6-1X16 N WA Z/J5
L	022237	2	WASHER LOCK 3/8
M	048527	2	SCREW SHC 3/8-16 X 3/4 G8.8 NZ
N	029289	1	TAPE ELEC 1/2 FOAM (AS REQ'D)
P	022770	2	SCREW RHM 1/4-20 X 3
Q	0F1733	1	DECAL CUSTOMER CONNECT INSIDE
6)			NEUTRAL BLOCK 390 / 200-400A
A	0D5466	2	BUS BAR NEUTRAL BLOCK 390
B	039287	1	SCREW HHC M8-1.25 X 45 G8.8 FT
C	022145	1	WASHER FLAT 5/16-M8 ZINC
D	022129	1	WASHER LOCK M8-5/16
E	045771	1	NUT HEX M8-1.25 G8 YEL CHR
F	022473	2	WASHER FLAT 1/4-M6 ZINC
G	022097	2	WASHER LOCK M6-1/4
H	045335	2	SCREW HHC 1/4-28 X 3/4 G5
J	0A7822	1	LUG SLDLSS 600/250-1/0 X 1/4-28

* ITEM INCLUDED WITH HARNESS
 ** ITEM INCLUDED WITH 0D5464B
 *** ITEM QTY DOUBLES FOR 277/480V
 **** ITEM USED WITH 277/480V UNITS ONLY

GROUP A

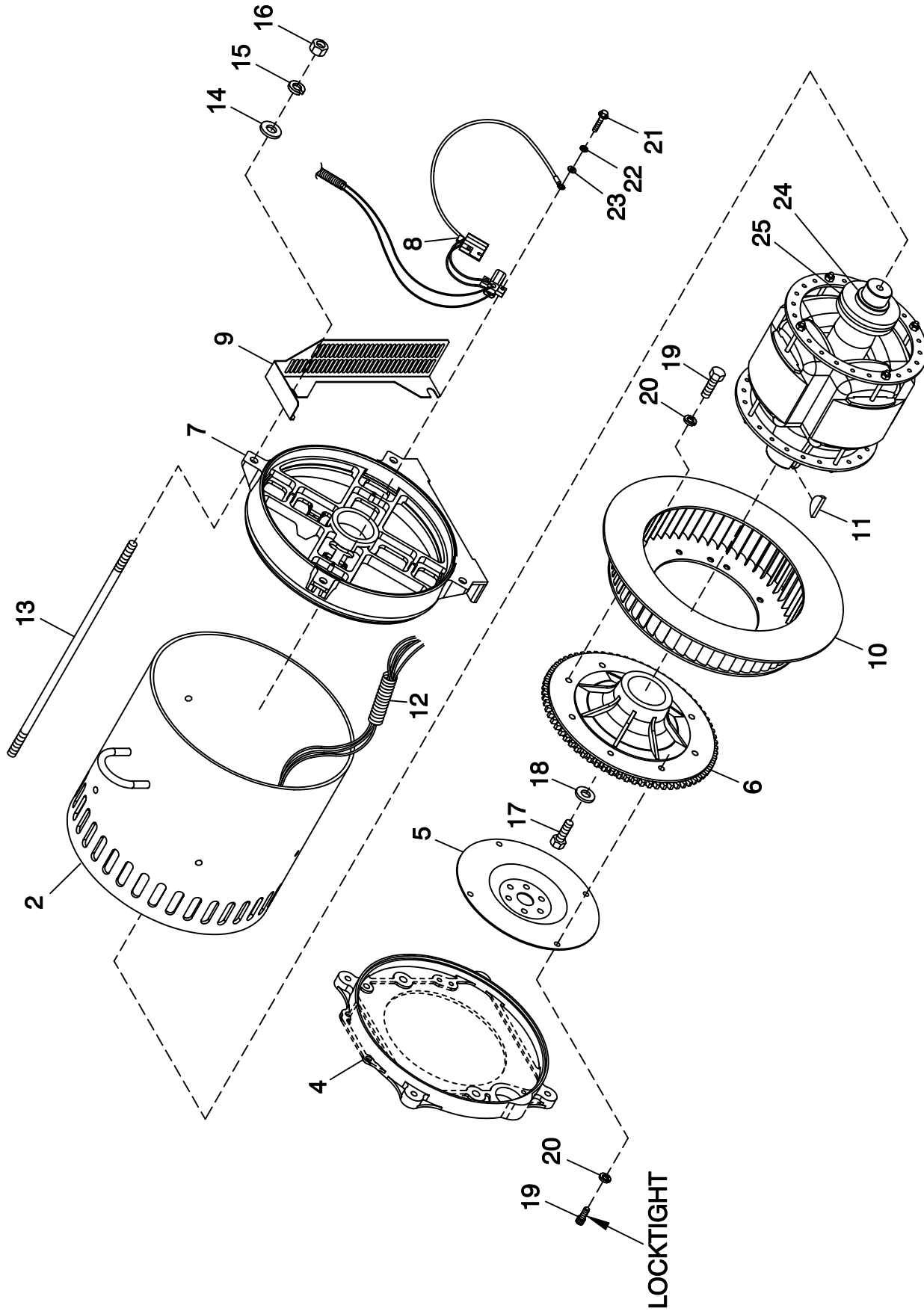

**EXPLODED VIEW: CPL ALTERNATOR DIRECT EXCITATION
DRAWING #: 0F4779**

GROUP A

APPLICABLE TO:

ITEM	PART #	QTY.	DESCRIPTION
1	0F3438	1	RTR 390 30AD1 CPL
	0F3440	1	RTR 390 40AD2 CPL HI-EF
	0F6188	1	ASSY RTR 390 30KD1 CPL
	0F6190	1	ASSY RTR 390 40KD2 CPL
2	0F3439	1	STR 390 30AD1 CPL
	0F3441	1	STR 390 40AD2 CPL
	0F6189	1	STR 390 30GD1 CPL
	0F6199	1	STR 390 40GD2 CPL
	0F6655	1	ASSY STR 390 30KD1 CPL
	0F6656	1	ASSY STR 390 40KD2 CPL
3	0C9708	1	INSTR HYPOT TEST
4	SEE ENGINE EV	REF	ENGINE ADAPTER
5	SEE ENGINE EV	REF	FLEXPLATE
6	0F5536	1	ASSY FLYWHEEL C2 CPL
7	0E5706	1	REAR BEARING CARRIER 390/DRCT
8	0F7874	1	ASSY BRUSH HOLDER 390/HSB
9	0F6124	1	GUARD REAR BEARING CARRIER CPL 3.0L 30KW
	0F6123	1	GUARD REAR BEARING CARRIER CPL 3.9L 40KW
10	0E6076	1	REVCOR FAN 12.63 X 2 W/PRESSDISK
11	023454	1	KEY WOODRUFF #E
12	077043F	1	CONDUIT FLEX 1-1/4" (30" LG)
13	04576100BU	4	STUD M14-2.0 570 G5 ZINC (30KW)
	04576100AQ	4	STUD M14-2.0 X 615 G5 ZINC
14	052646	4	WASHER FLAT M14
15	043123	4	WASHER LOCK M14
16	051779	4	NUT HEX M14-2.0 G8 YEL CHR
17	0A2601	1	SCREW HHC M16-2.0 X 45 G8.8
18	0A2602	1	WASHER FLAT .688 ID X 3.25 OD
19	0F3398	8	SCREW SHC M10-1.5 X 16 G10.9
20	046526	8	WASHER LOCK M10
21	0C3993	4	SCREW HHTT M4-0.7 X 25 BP
22	022264	4	WASHER LOCK #8-M4
23	038150	4	WASHER FLAT #8 ZINC
24*	047248	1	BALL BEARING-45 MM
25*	070892	1	SLIP RING MACHINED

* ROTOR REPLACEMENT PARTS

GROUP B

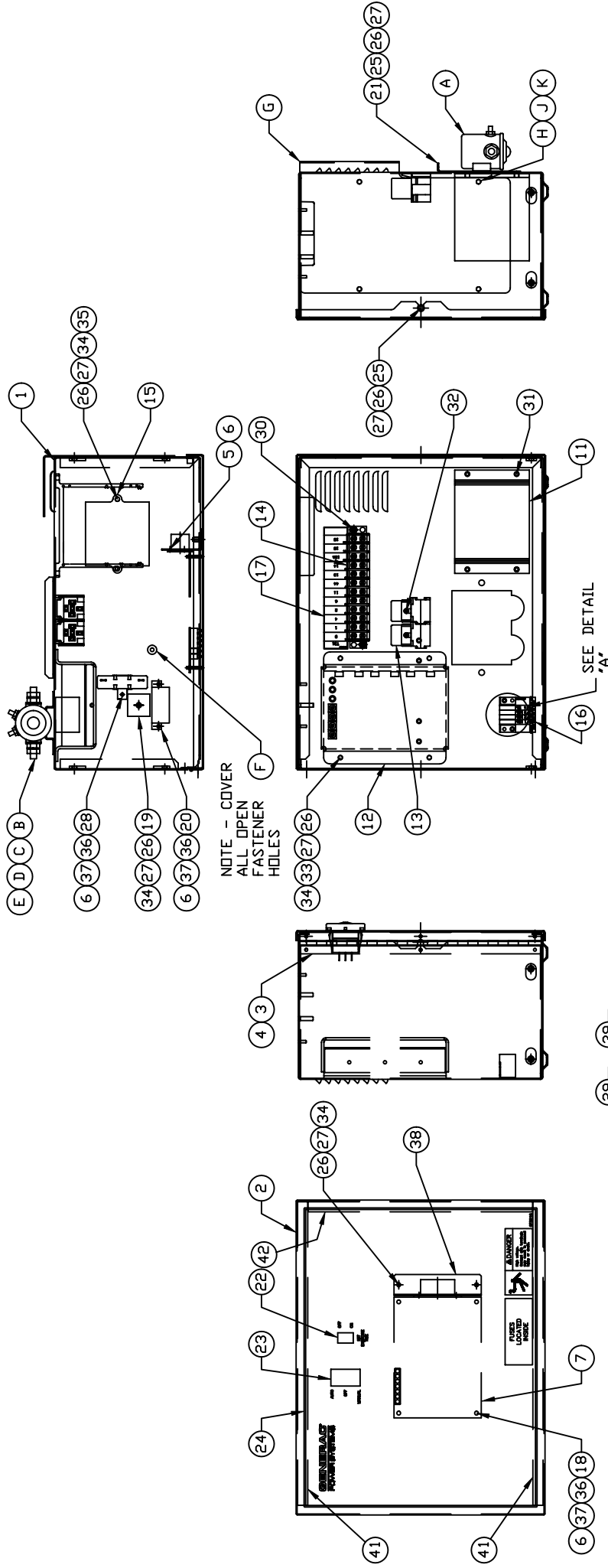

EXPLODED VIEW:
R-100 1800 RPM 3.0/3.9L
DRAWING #: 0F7376D

APPLICABLE TO:

ITEM	PART #	QTY.	DESCRIPTION
<u>COMPONENTS INCLUDED IN 01827E</u>			
1	0F1823A	1	ENCL HSB CONTROL PANEL
2	0F3078	1	COVER CONTROL PANEL
3	0F2606	1	HINGE CONTINUOUS H-PANEL
4	036261	6	RIVET POP .125 X .275 SS
5	043181	4	SCREW PHM M3-0.5 X 10MM
6	052777	7	WASHER FLAT M3
7	0F4245E	1	ASSY PCB CPL CTRLR 1800 RPM
8	0F1262	4	HOLDER FUSE WICKMANN 178.6150
9	0F1263	1	ADPTR RH SIDE WICKMAN 178.6191
10	0F1264	1	ADPTR LH SIDE WICKMAN 178.6192
11	0F1725C	1	ASSY PCB 2AMP 12V UL BATT CHGR
12	067680	1	ASSY VOLTAGE REGULATOR 60HZ
13	0E6875A	2	RELAY 12VDC C FORM W/DIODE
14	055911	1	BLOCK TERM 20A 12 X 6 X 1100V
15	0E3161	1	ASSY PCB BOSCH GOV DRIVER
16	0F5459	1	DECAL CPL CONTROL PANEL FUSES
17	0F5462	1	DECAL CPL 3.9L TB1
18	0A5062J	4	SPACER 9.5H 3.2 ID
19	029673	1	DIO BRIDGE 25A 600V
20	048467	1	CIRCT BRK 7 X 1 ETA 46-500-P
21	0F1958	1	PLATE,HARNES CLAMP
22	082573	1	SWITCH RKR DPST 125V SPD
23	0E4494	1	SWITCH RKR DPDT ON-OFF-ON
24	0F3215	1	DECAL CONTROL HSB
25	0F5886	3	SCREW HHPM M5-0.8 X 12
26	051713	12	WASHER FLAT M5
27	049226	12	WASHER LOCK M5
28	0F5752F	1	RES WW 15R 5% 25W QK CONN
29	0F5884	2	SCREW PHTT M3.5-0.6 X 10
30	0F5896	2	SCREW PHTT M3.5-0.6 X 16
31	0C2265	4	SCREW PHTT M4-0.7 X 12 ZYC
32	0C3990	2	SCREW PHTT M4-0.7 X 10 ZYC
33	091526	4	SCREW PPHM M5-0.8 X 12 ZNC
34	051716	9	NUT HEX M5-0.8 G8 CLEAR ZINC
35	079224	2	SCREW PPHM M5-0.8 X 30 SS
36	043182	7	WASHER LOCK M3
37	051714	7	NUT HEX M3-0.5 G8 YEL CHR
38	0F3192	1	SUPPORT ANGLE PCB
39	0E7403C	1	FUSE ATO TYPE 15 AMP (BLUE)
40	0F4416	1	HARN 1800RPM R-100 CONTROL PNL (NOT SHOWN)
41	0F6305	2	SEAL COVER 3.18 X 12.7 X 382
42	0F6305A	1	SEAL COVER 3.18 X 12.7 X 283
<u>COMPONENTS INCLUDED IN 0F7376D</u>			
A	056739	1	RELAY SOLENOID 12VDC PNL MNT
B	047411	2	SCREW HHC M6-1.0 X 16 G8.8
C	022473	4	WASHER FLAT 1/4-M6 ZINC
D	022097	2	WASHER LOCK M6-1/4
E	049813	2	NUT HEX M6 X 1.0 G8 YEL CHR
F	0F6145	A/R	SEAL WEATHER .45"DIA
G	0F2627A	1	COVER CONTROL PANEL SIDE
H	049815	4	SCREW HHC M5-0.8 X 16 G8.8
J	049226	4	WASHER LOCK M5
K	023897	4	WASHER FLAT #10 ZINC

GROUP C

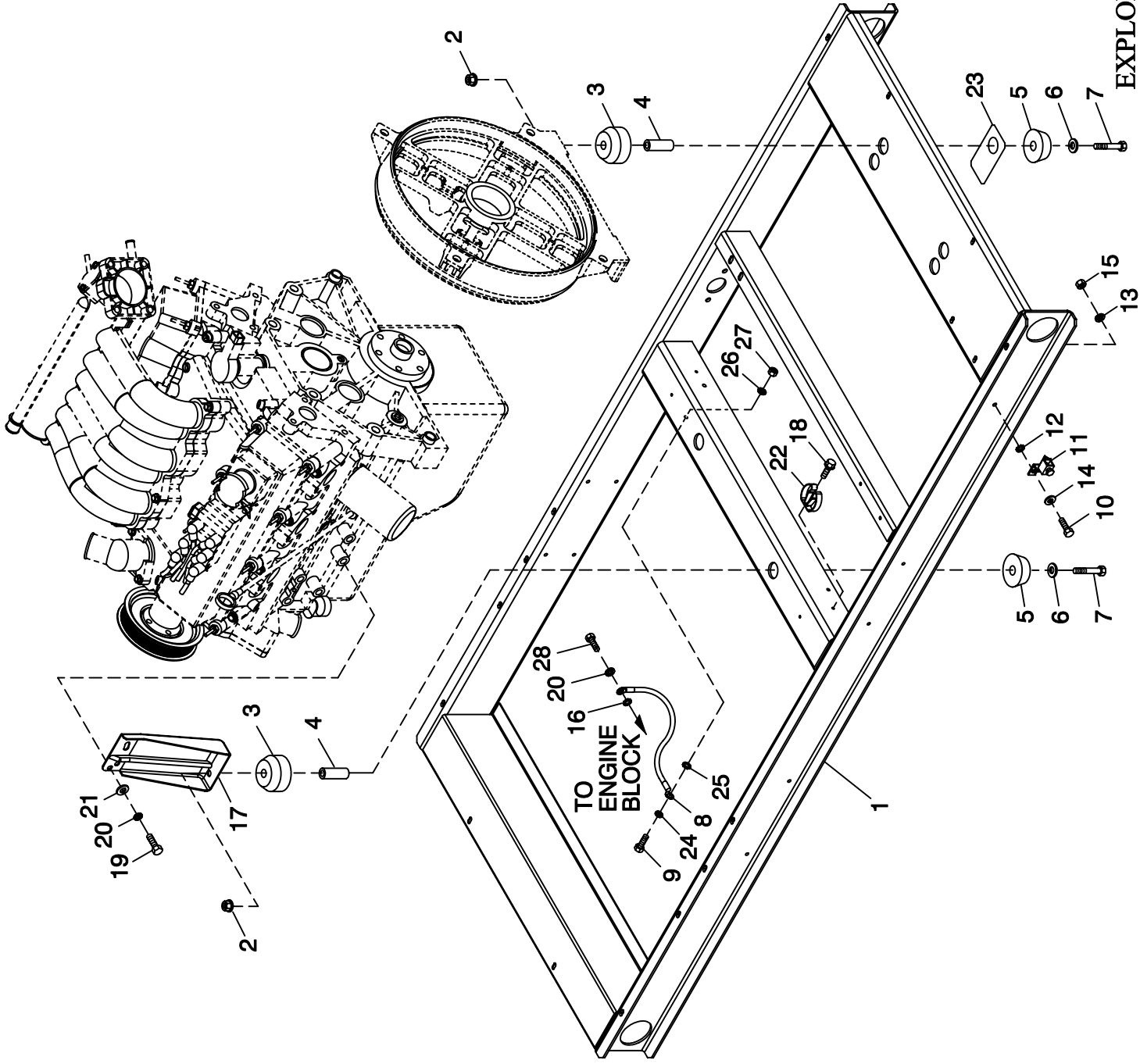

EXPLODED VIEW: MOUNTING BASE 3.0L 30KW C2 CPL
DRAWING #: 0F3513

GROUP C

APPLICABLE TO:

ITEM	PART #	QTY.	DESCRIPTION
1	0F3270A	1	MTG BASE 3.0L 30KW C2
2	052860	4	NUT FLANGED HEX M12-1.75
3	052251	4	DAMPENER VIBRATION 40 BLUE
4	052257	4	SPACER .49 X .62 X 1.87 PWDR/ZNC
5	052252	4	DAMPENER VIBRATION
6	052259	4	WASHER FLAT M12
7	052891	4	SCREW HHC M12-1.75 X 80 G8.8
8	0536210410	1	ASSY WIRE 14.00"
9	042909	1	SCREW HHC M8-1.25 X 30 G8.8
10	047411	1	SCREW HHC M6-1.0 X 16 G8.8
11	055414	1	LUG SLDLSS #2-#8 X 17/64 CU
12	022447	1	WASHER SHAKEPROOF INT 1/4
13	022097	1	WASHER LOCK M6-1/4
14	022473	2	WASHER FLAT M6-1/4 ZINC
15	049813	1	NUT HEX M6 -1.0 G8 YEL CHR
16	022261	1	WASHER SHAKEPROOF INT 3/8
17	0E8824	2	STAMPING ENG FOOT 3.0L FORD
18	045764	1	SCREW HHTT M4-0.7 X 8 BP
19	049814	4	SCREW HHC M10-1.5 X 25 G8.8
20	022302	5	WASHER LOCK 7/16
21	022131	4	WASHER FLAT 3/8-M10 ZINC
22	065852	1	SPRING CLIP HOLDER .37-.62
23	0F5898	2	PLATE ALT VARMINT
24	022129	1	WASHER LOCK M8-5/16
25	026204	1	WASHER SHAKEPROOF INT 5/16
26	022145	1	WASHER FLAT 5/16-M8 ZINC
27	045771	1	NUT HEX M8-1.25 G8 CLEAR ZINC
28	051755	1	SCREW HHC M10-1.5 X 16 G8.8

GROUP C

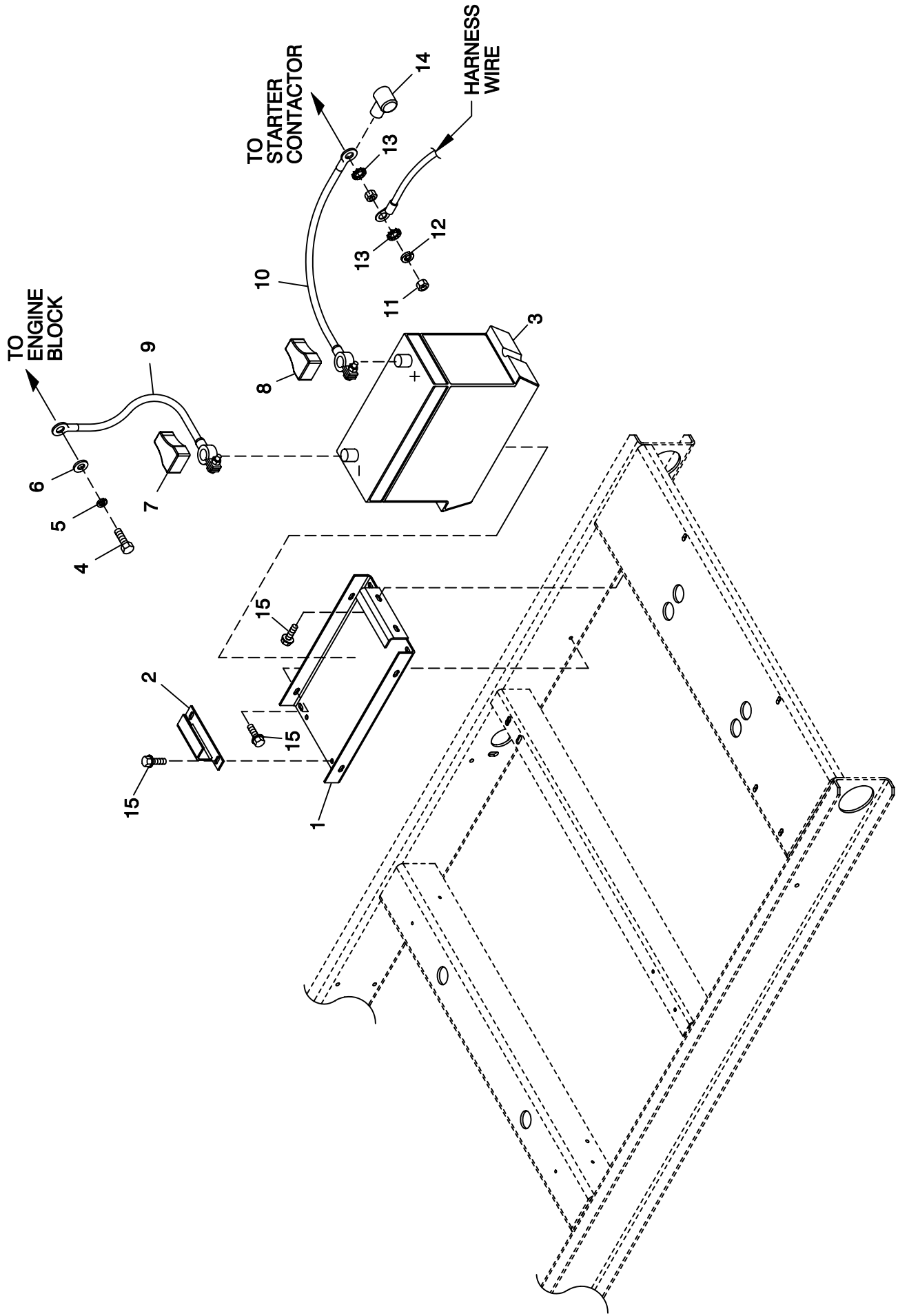

EXPLODED VIEW:
BATTERY
DRAWING #: 0F5668

EXPLODED VIEW: BATTERY

DRAWING #: 0F5668

GROUP C

APPLICABLE TO:

ITEM	PART #	QTY.	DESCRIPTION
1	0F3408	1	TRAY BATTERY
2	0F3411	1	STRAP BATTERY RETAINMENT
3	058208	REF	BATT 12VDC 24F 625
4	036833	1	SCREW HHC 3/8-16 X 1 G8
5	022237	1	WASHER LOCK 3/8
6	022131	1	WASHER FLAT 3/8-M10 ZINC
7	050331A	1	BATT POST COVER RED +
8	050331	1	BATT POST COVER BLK -
9	038805H	1	CABLE BATT BLK #1 X 23.00
10	038804Y	1	CABLE BATT RED #1 X 35.00
11	045771	1	NUT HEX M8-1.25 G8 YEL CHR
12	022129	1	WASHER LOCK M8-5/16
13	027482	2	WASHER SHAKEPROOF EXT 5/16 STL
14	075763	1	BOOT BATTERY CABLE
15	0C2454	6	SCREW THF M6-1 X 16 N WA Z/JS

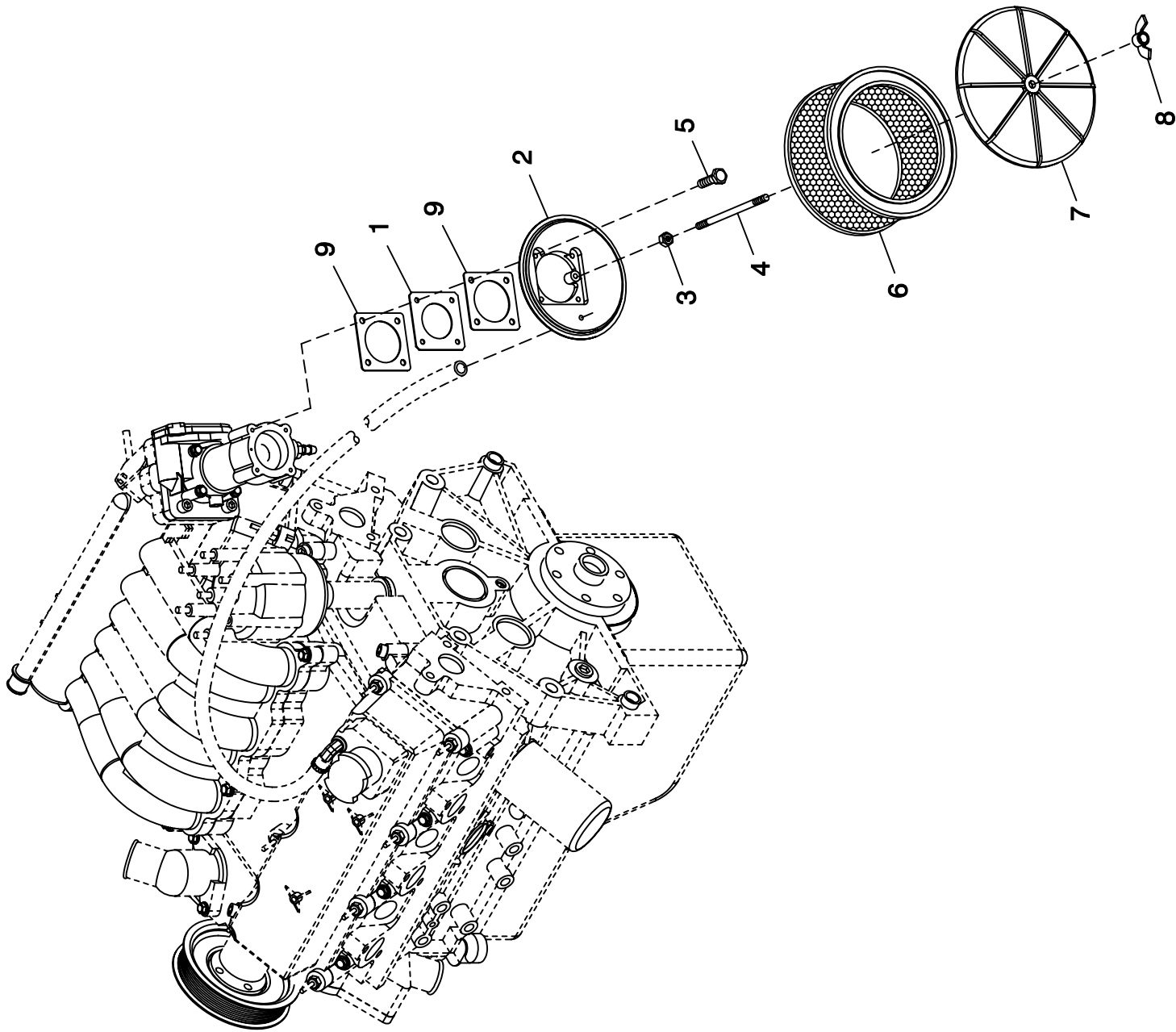

EXPLODED VIEW:
AIR CLEANER 3.0L FORD C2
DRAWING #: 0F3516

EXPLODED VIEW: AIR CLEANER 3.0L FORD C2

DRAWING #: 0F3516

GROUP D

APPLICABLE TO:

ITEM	PART #	QTY.	DESCRIPTION
1	0E5193	1	PLATE AIR CLEANER ADAPTER
2	0E0519A	1	ADAPTER CARBURETOR WPVC CONN
3	022127	1	NUT HEX 1/4-20 STEEL
4	062974	1	STUD TH 1/4-20 X 4-1/2 G2 ZNC
5	052619	4	SCREW HHC M5-0.8 X 20 G8.8
6	0C8127	1	ELEMENT AIR CLEANER
7	0A5547	1	COVER - AIR CLEANER
8	037561	1	NUT WING 1/4-20 NYLK
9	0E6586	2	GASKET BOSCH 32 & 40

GROUP D

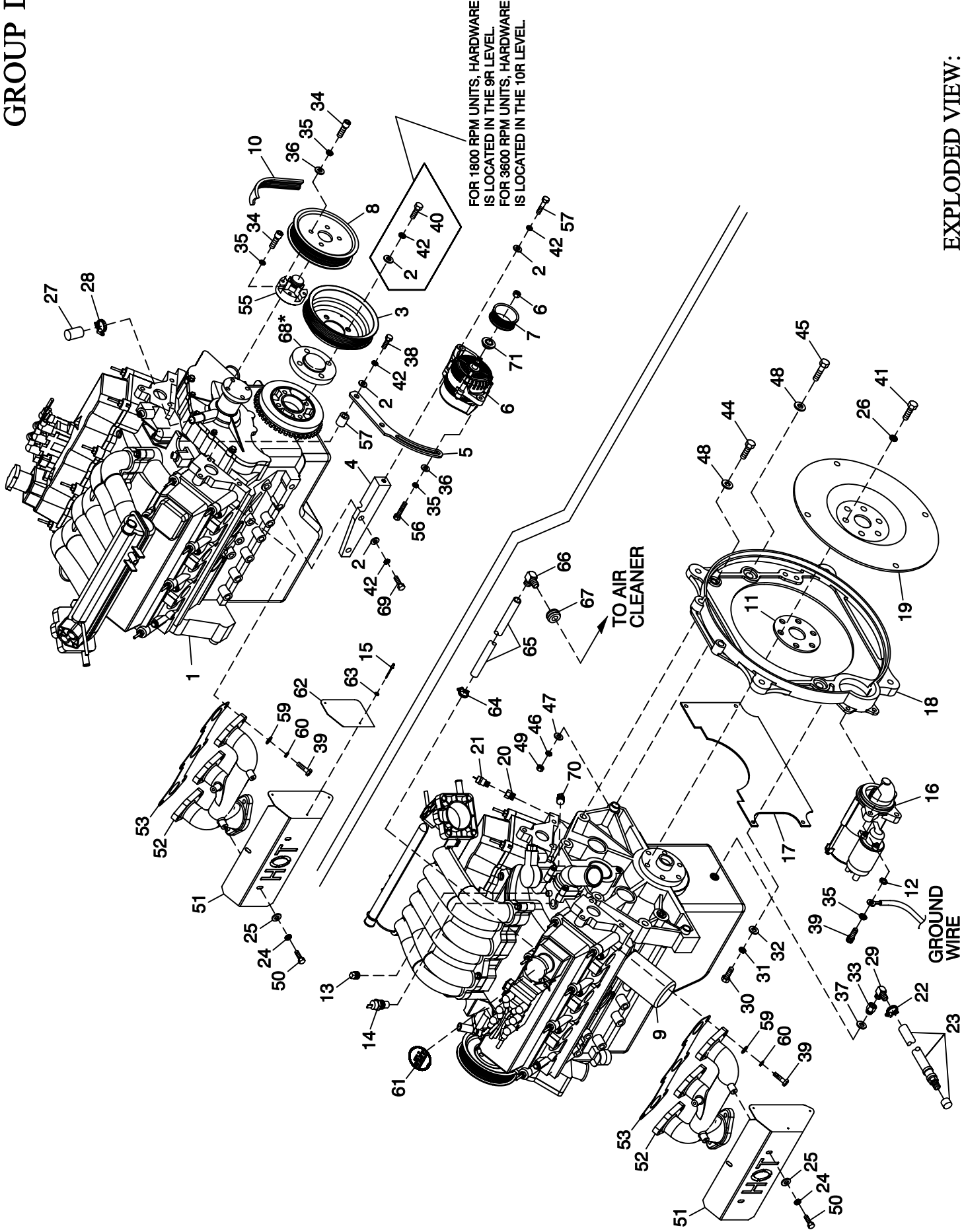

EXPLODED VIEW:
ENGINE COMMON PARTS 3.0L FORD CPL
DRAWING #: 0F6845

**EXPLODED VIEW: ENGINE COMMON PARTS 3.0L FORD CPL
DRAWING #: 0F6845**

GROUP D

APPLICABLE TO:

ITEM	PART #	QTY.	DESCRIPTION
1	0F6842	1	ENGINE 3.0L FORD (FD) (MAKE) CPL
2	022131	14	WASHER FLAT 3/8-M10 ZINC (1800 RPM ONLY)
	022131 *	9	WASHER FLAT 3/8-M10 ZINC (3600 RPM ONLY)
3	0E8963	1	PULLEY CRANKSHAFT 3.0L FORD (1800 RPM ONLY)
	0E6309	1	PULLEY CRANKSHAFT 3.0L FORD (3600 RPM ONLY)
4	0F6912	1	BRACKET R/H SIDE D.C. ALT
5	0F6873	1	BRACKET TENSIONER
6	0E9868A	1	ALTERNATOR DC W/OUT PULLEY
7	0F3216	1	PULLEY 80 OD DC ALTERNATOR (1800 RPM)
	0F3216C	1	PULLEY 132 OD DC ALTERNATOR (3600 RPM)
8	0E6308	1	PULLEY WATERPUMP 3.0L FORD (RD)
9	0E7080	REF.	OIL FILTER 3.0L FORD
10	0D3488F	1	BELT SERPENTINE 38.35" LG (1800 RPM)
	0D3488B *	1	BELT SERPENTINE 40.85" LG (3600 RPM)
11	0E8940	1	SPACER FLEXPLATE HSB (1800 RPM)
	0F5753 *	1	SPACER FLEX PLATE 3.0L FORD (3600 RPM)

ITEM	PART #	QTY.	DESCRIPTION
12	027482	1	WASHER SHAKEPROOF EXT 5/16 STL
13	061012	1	PLUG STD PIPE 1/8 SOCKET HEAD
14	0A6751	1	SWITCH HI-TEMP 245D X 3/8NPT
15	033472	3	RIVET POP .125 X .400 AL
16	0E6729	1	STARTER 12V
17	0E6703	1	COVER FLYWHEEL ACCESS 3.0L HSB
18	0E6667	1	ENGINE ADAPTER 3.0L FORD
19	0F3903 *	1	FLEX PLATE 2 POLE 3.0L FORD (3600 RPM)
	0E5048	1	FLEXPLATE HSB 3.0L FORD (1800 RPM)
20	035579	1	BUSHING REDUCER 1/4 TO 1/8
21	0A8584	1	SWITCH OIL PRESSURE 10 PSI 2 POL
22	0C7649	1	CLAMP HOSE .38-.87
23	069860E	1	HOSE DRAIN ASSY 28"
24	083896	6	WASHER LOCK 1/4-M6 SS
25	084929	6	WASHER FLAT 1/4 SS
26	0F3844	6	WASHER FLAT .45 X 1.00
27	0F6151	1	CAP RUBBER
28	057823	1	CLAMP HOSE #10 .56-1.06
29	043790	1	BARBED EL 90 3/8 NPT X 3/8
30	047411	4	SCREW HHC M6-1.0 X 16 G8.8
31	022097	4	WASHER LOCK M6-1/4
32	022473	4	WASHER FLAT 1/4-M6 ZINC
33	057765	1	ADAPTER M14-1.50 X 3/8 NPT
34	040976	8	SCREW SHC M8-1.25 X 20 G12.9
35	022129	12	WASHER LOCK M8-5/16
36	022145	5	WASHER FLAT 5/16-M8 ZINC
37	057772	1	WASHER NYLON .565
38	057645	3	SCREW HHC M10-1.5 X 50 G8.8
39	0D9913	12	SCREW SHC M8-1.25 X 35 SS
40	059980	4	SCREW HHC M10-1.5 X 25 G10.9 (1800 RPM ONLY)
41	0D5417	REF.	SCREW HHC M10-1.0 X 25 G10.9
42	046526	14	WASHER LOCK M10 (1800 RPM ONLY)
	046526 *	9	WASHER LOCK M10 (3600 RPM ONLY)
44	059982	4	SCREW SHC M12-1.75 X 45 G10.9
45	098780	2	SCREW HHC M12-1.75 X 65 G8.8
46	051769	2	WASHER LOCK M12
47	049808	2	WASHER FLAT M12
48	051430	6	WASHER SHAKEPROOF INT 1/2
49	045773	2	NUT HEX M12-1.75 G8 YEL CHR
50	085296	6	SCREW HHC 1/4-20 X 1/2 SS
51	0E7202	2	HEAT SHIELD 260 X 80 HOT
52	0E5527	2	MANIFOLD EXHAUST 3.0L FORD
53	0E7163	2	GASKET EXHAUST 3.0L FORD
54	0F6840 *	1	HARN ENG 3.0L 3600RPM R-100 (NOT SHOWN) (3600 RPM)
	0F6841	1	HARN ENG 3.0L 1800RPM R-100 (NOT SHOWN) (1800RPM)
55	0F6809	1	ADAPTER, WATER PUMP
56	039253	1	SCREW HHC M8-1.25 X 20 G8.8
57	0F6833	2	SPACER .44 X .87 X 1.14 AL
59	070008	12	WASHER FLAT M8 SS
60	070006	12	WASHER LOCK M8 SS
61	0F5114	1	DECAL REFER TO OWNERS MANUAL
62	0F5966	1	REFLECTIVE HEAT SHIELD 3.0L FD
63	022985	3	WASHER FLAT #6 ZINC
64	057822	1	CLAMP HOSE #8 .53-1.00
65	059057	1	HOSE 3/4 ID SAE-30R2 (14" LG)
66	057795A	1	BARBED EL 90 3/4 PLASTIC
67	057796	1	GROMMET
68 *	0E6313A *	1	SPACER PULLEY 3.0L FORD (FD) (3600 RPM ONLY)
69	049541	2	SCREW HHC M10-1.5 X 35 G8.8
70	026925	1	PLUG STD PIPE 3/8 STEEL SQ HD
71	0F3217	1	SPACER DC ALTERNATOR PULLEY

* FOR 3600 RPM UNITS ONLY

GROUP D

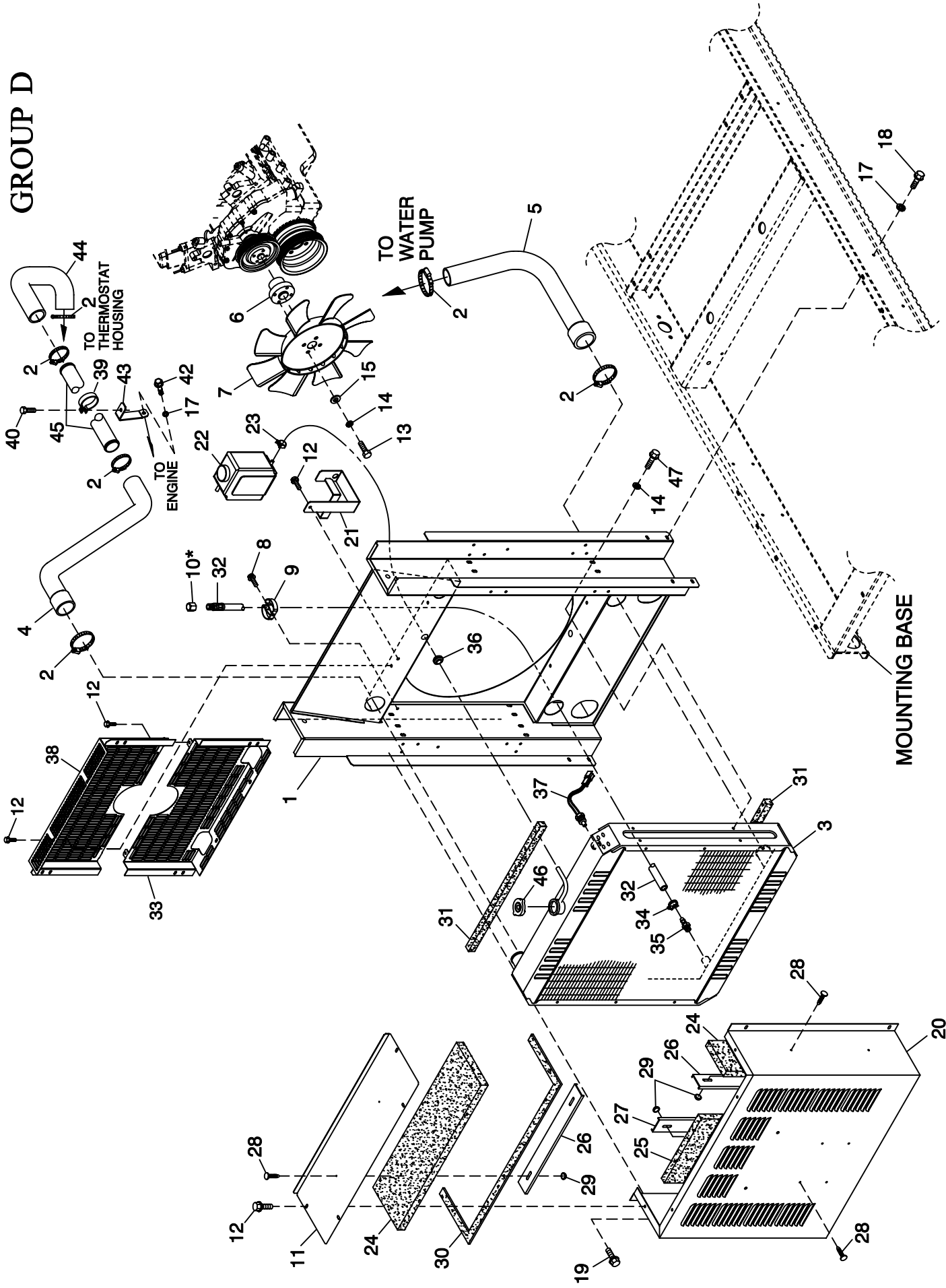

EXPLODED VIEW:
 C2 COOLING SYSTEM & FAN DRIVE
 DRAWING #: 0F6879

EXPLODED VIEW: C2 COOLING SYSTEM & FAN DRIVE
DRAWING #: 0F6879

GROUP D

APPLICABLE TO:

ITEM	PART #	QTY.	DESCRIPTION
1	0F3203A	1	WELDMENT RAD SUPPORT 3.0L C2
2	035685	6	CLAMP HOSE #28 1.32-2.25
3	0F2608A	1	RADIATOR 598 X 568 X 49,CPL LH
4	0F6761	1	HOSE UPPER RAD CPL C2 3.0L
5	0F3228	1	HOSE LOWER RAD CPL C2 3.0L
6	0F5143	1	SPACER FAN 3.0L C2
7	0F0230A	1	FAN COOLING 16" DIA 8 BLADE
8	045764	1	SCREW HHTT M4-0.7 X 8 BP
9	065852	1	SPRING CLIP HOLDER .37-.62
10 *	069811	REF.	CAP HEX 1/4 NPT BRASS
11	0F3312	1	DUCT INNER DISCHARGE TOP C2
12	0C2454	13	SCREW THF M6-1 X 16 N WA Z/J
13	039253	4	SCREW HHC M8-1.25 X 20 G8.8
14	022129	12	WASHER LOCK M8-5/16
15	022145	4	WASHER FLAT 5/16-M8 ZINC
17	022097	10	WASHER LOCK M6-1/4
18	0C8566	8	SCREW HHFC M6-1.0 X 20 G8.8
19	0E3257	4	SCREW HWHTF M6-1.0 X 16
20	0F3313	1	DUCT INNER DISCHARGE C2
21	080712	1	BRKT COOLANT RECOVERY TANK
22	076749	1	TANK COOLANT RECOVERY
23	048031C	1	CLAMP HOSE BAND 1/4
24	0F4051D	3	INSULATION INNER DUCT
25	0F4073C	1	INSUL DUCT SIDE OR INNER DUCT
26	0F3890	3	RETAINER INSULATION (450)
27	0F3890C	2	RETAINER INSULATION (220)
28	0F3072	10	INSULATION RETAINMENT HANGER
29	078115	10	WASHER SELF LOCKING DOME
30	089961	1	FOAM STRIP 3/4" WIDE X 3/16" THK (46" LG)
31	052250	2	TAPE FOAM 1 X 1 (22.5" LG)
32	069860E	1	HOSE DRAIN ASSY 28"
33	0F8085	1	GUARD FAN C2 CPL, BOTTOM
34	0C7649	1	CLAMP HOSE .38-.87
35	055596	1	BARBED STR 3/8 NPT X 3/8
36	089685	1	GROMMET .75 X .12 X .50
37	0E0561	1	ASSY WATER LEVEL SENSOR C/E PL
38	0F8085A	1	GUARD FAN C2 CPL TOP
39	055934V	2	CLAMP VINYL 1.5 X .281 Z
40	092079	2	SCREW HHTT M6-1.0 X 25 BP
42	076340	2	SCREW HHFC M6-1.0 X 16 G8.8
43	0F6657	2	SUPPORT TUBE RADIATOR
44	0F6631	1	HOSE RADIATOR ENGINE
45	0F6746	1	TUBE UPPER COOLANT C4 3.0L
46	090283	1	CAP RADIATOR 13 PSI
47	0F8651	8	SCREW HHFC M8-1.25 X 20 W/M6

* ITEM #10 IS INCLUDED WITH ITEM #32.

GROUP D

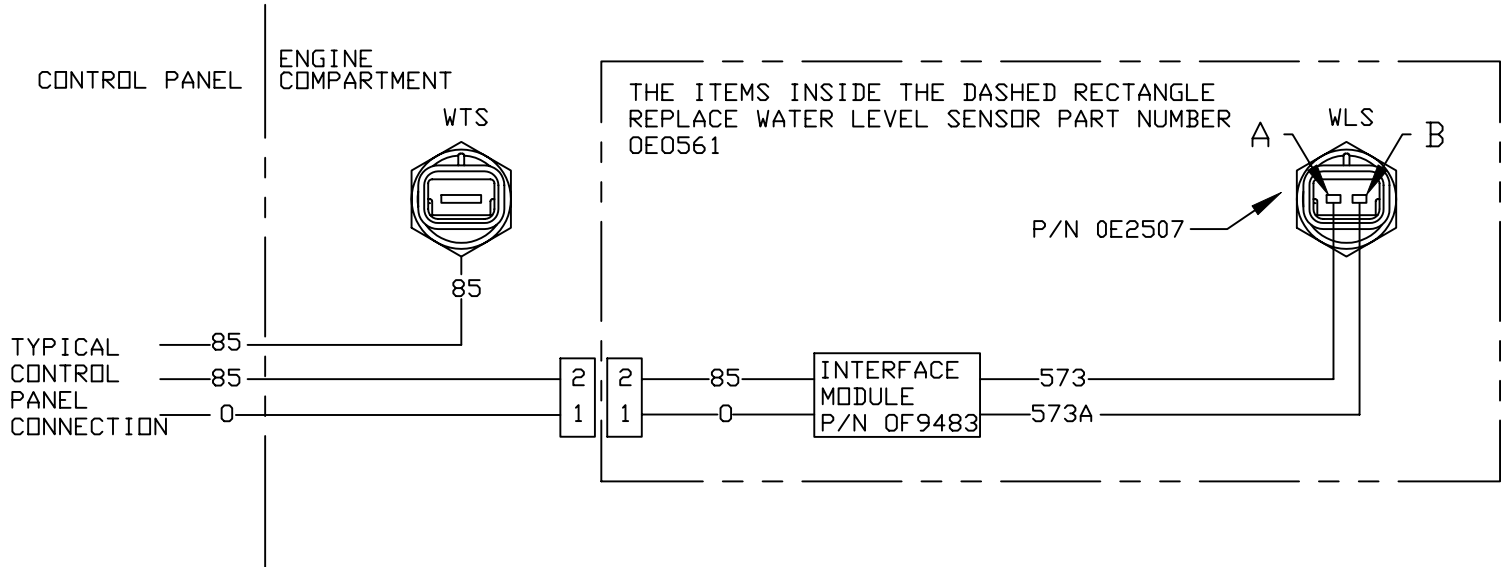

WIRING DIAGRAM FOR NEW COOLANT LEVEL SENSOR

MECHANICAL DIAGRAM FOR NEW COOLANT LEVEL SENSOR INSTALATION

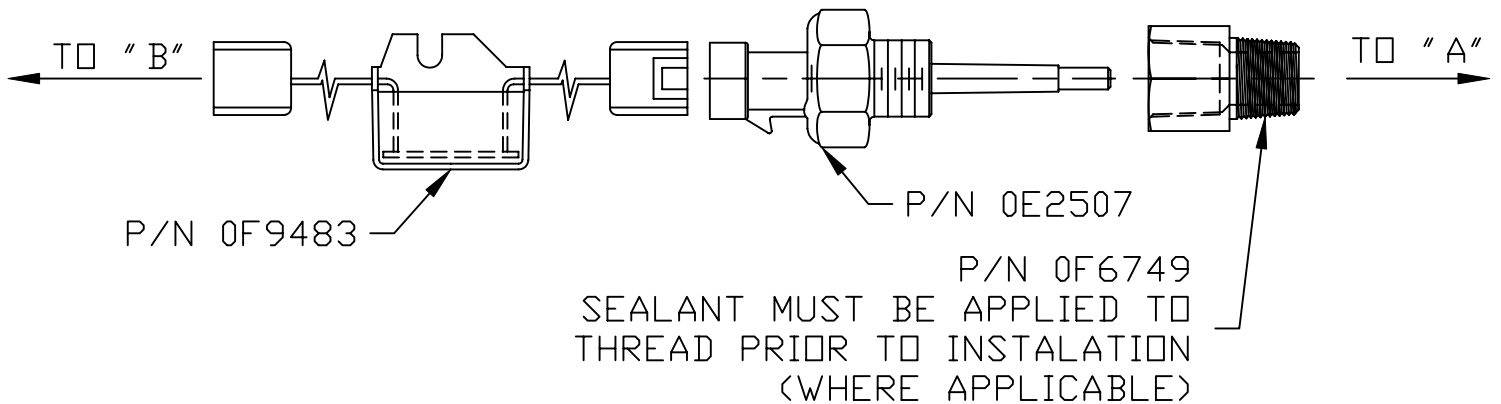

"A" = EXISTING COOLANT LEVEL SENSOR LOCATION ON UNIT
 "B" = EXISTING COOLANT LEVEL SENSOR WIRE HARNESS CONNECTOR

BLANK PAGE

GROUP E

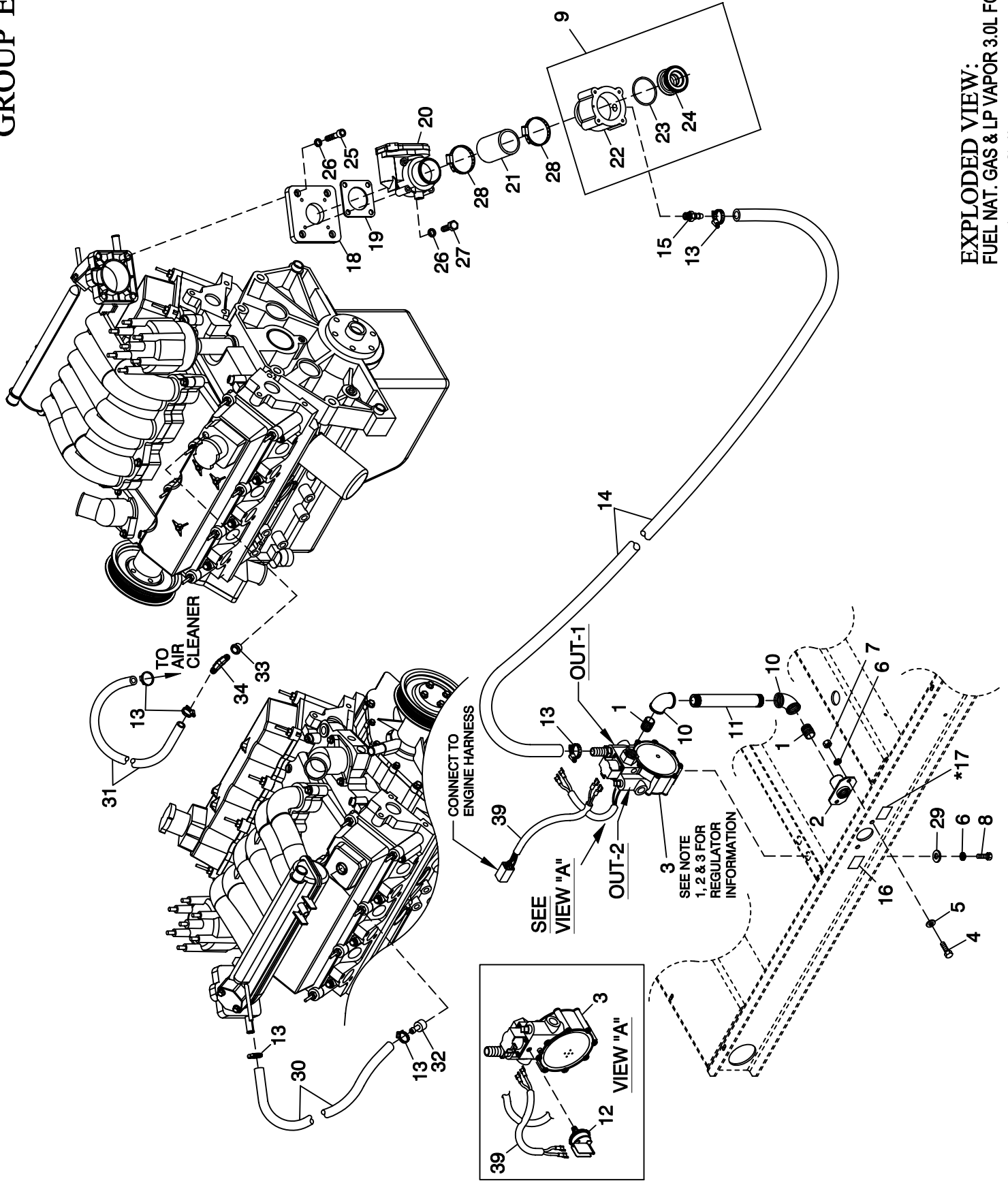

EXPLODED VIEW: FUEL NAT. GAS & LP VAPOR 3.0L FORD 4-POLE
DRAWING #: 0F3521

GROUP E

APPLICABLE TO:

ITEM	PART #	QTY.	DESCRIPTION
1	026915	2	NIPPLE CLOSE 3/4 X 1.375
2	075580	1	FLANGE FUEL INLET
3	0F6390	1	REGULATOR ASSEMBLY DUAL FUEL
4	039253	2	SCREW HHC M8-1.25 X 20 G8.8
5	022145	2	WASHER FLAT 5/16-M8 ZINC
6	022129	4	WASHER LOCK M8-5/16
7	045771	2	NUT HEX M8-1.25 G8 CLEAR ZINC
8	042907	2	SCREW HHC M8-1.25 X 16 G8.8
9	0E9295A	1	ASSY THROTTLE 27MM
10	026812	2	ELBOW 90D 3/4NPT
11	025424	1	NIPPLE PIPE 3/4NPT X 6
12	0F3869	1(REF)	SWITCH, PRESSURE GAS 5" RISE (INCLUDED WITH I/N 3)
13	057823	6	CLAMP HOSE #10 .56 - 1.06
14	059194	1	HOSE 5/8 ID LPG & NG (31.5" LG)
15	044117	1	BARBED STR 3/8 NPT X 5/8
16	0D1509	1	DECAL INLET PRESSURE
17*	050279	1	DECAL FUEL INLET NG (NATURAL GAS APPLICATION)
	050280	1	DECAL FUEL INLET LPG (LP VAPOR APPLICATION)
18	0E6123	1	INTAKE ADAPTER 3.0L FORD-BOSCH
19	0E6586	1	GASKET BOSCH 32
20	0E4395	1	ACTUATOR BOSCH 32 GOVERNOR
21	057753B	1	HOSE 1.5 ID X 2 LG 20R4
22	0E6382A	1(REF)	VENTURI HOLDER W/32MM ACTUATOR
23	0E7121	1(REF)	O-RING 47.625 ID X 2.38 WIDTH
24	0E6376A	1(REF)	VENTURI, 27 ID THROTTLE W/CHOKE
25	047487	4	SCREW SHC M6-1.0 X 18 G12.9
26	022097	8	WASHER LOCK M6-1/4
27	051751	4	SCREW HHC M6-1.0 X 50 G8.8
28	035685	2	CLAMP HOSE #28 1.32-2.25
29	0A2038	2	WASHER FLAT 3/8 ZINC
30	047290	1	HOSE 3/8 ID SINGLE BRAID (305mm [12"] LONG)
31	047290	1	HOSE 3/8 ID SINGLE BRAID (432mm [17"] LONG)
32	0A4121	1	VALVE PCV
33	0E6609	1	GROMMET ROCKER COVER 3.0LFORD
34	049099	1	BARBED EL 90 3/8 X 3/8 PLST
35**	055934M	1	CLAMP VINYL .75 X .343 Z
36**	047411	1	SCREW HHC M6-1.0 X 16 G8.8
37**	022097	1	WASHER LOCK M6-1/4
38**	022473	1	WASHER FLAT 1/4-M6 ZINC
39	0F6155	1	HARNESS, CPL FUEL JUMPER

NOTES:

- REGULATOR (I/N 3) AS SHOWN IN ILLUSTRATION IS SET UP FOR NATURAL GAS APPLICATION.
- TO CONFIGURE REGULATOR FOR LP VAPOR, SWITCH HOSE BARB, HOSE CLAMP (I/N 13) AND HOSE (I/N 14) FROM "OUT-1" TO "OUT-2". REPLACE PIPE PLUG FROM "OUT-2" TO "OUT-1". USE PIPE SEALANT ON HOSE BARB AND PIPE PLUG. MAKE SURE TO KEEP PORTS FREE FROM DEBRIS DURING RECONFIGURATION PROCESS.
- FOR LP VAPOR APPLICATION SUBSTITUTE LPG FUEL INLET DECAL P/N 050280 FOR NG FUEL INLET DECAL P/N 050279 (ITEM17).
- WHEN SWITCHING FUEL TYPES, THE PROPER DIP SWITCH SETTINGS MUST BE MADE TO THE CONTROL PANEL. SEE OWNERS MANUAL, FUEL SECTION FOR MORE DETAILS.

** NOT SHOWN-USED TO HOLD #31 IN PLACE

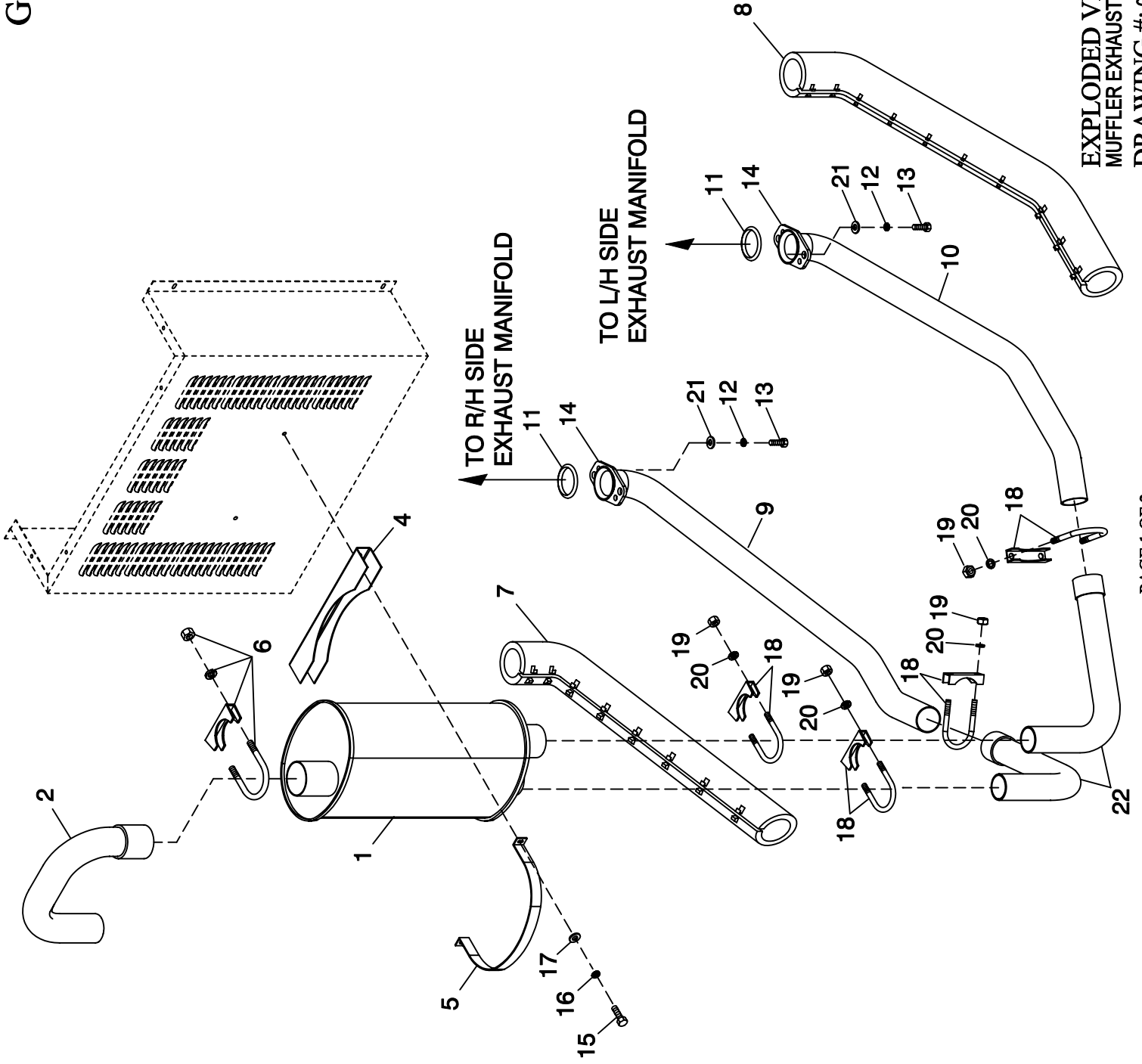

EXPLODED VIEW:
MUFFLER EXHAUST 3.0L CPL 30KW C2
DRAWING #: 0F3523

EXPLODED VIEW: MUFFLER EXHAUST 3.0L CPL 30KW C2
DRAWING #: 0F3523

GROUP F

APPLICABLE TO:

ITEM	PART #	QTY.	DESCRIPTION
1	0F0738	1	MUFFLER 7" X 9"-(2) 2" IN/2.5" OUT
2	0F2808B	1	PIPE EXHAUST MUFFLER
4	0F2830	1	MUFFLER BRACKET STIFFENER
5	0F2962	1	MUFFLER STRAP
6	080762	1	BOLT U 3/8-16 X 2.62
7	0E0170B	1	EXHAUST BLANKET 800MM (C2)
8	0E0170	1	EXHAUST BLANKET 750MM (C2)
9	0F4343	1	EXHAUST PIPE 3.0L C2 CPL RH
10	0F4344	1	EXHAUST PIPE 3.0L C2 CPL LH
11	044149	2	GASKET EXHAUST RING
12	085917	4	WASHER LOCK 3/8 SS
13	0D2611	4	SCREW HHC 3/8-16 X 1-3/4 SS
14	0E8816	2	EXHAUST FLANGE 2" PIPE
15	047411	2	SCREW HHC M6-1.0 X 16 G8.8
16	022097	2	WASHER LOCK M6-1/4
17	022473	2	WASHER FLAT 1/4-M6 ZINC
18	036797	4	BOLT U 5/16-18 X 2.25
19	024114	8	NUT HEX 5/16-24 STEEL
20	022129	8	WASHER LOCK M8-5/16
21	088775	4	WASHER FLAT 3/8 SS
22	0F7100	2	PIPE EXHAUST ELBOW 3.0L C2

GROUP F

○ INSULATION AND RETAINERS LOCATED ON THE NEAR SIDE.
 ○ INSULATION AND RETAINERS LOCATED ON THE FAR SIDE.
 ○ RETAINER (30) (32) (33)
 ○ TYPICAL MOUNTING OF ACOUSTIC INSULATION. SEE DETAIL "A" AND "B" FOR SPLITTER VARIATIONS.

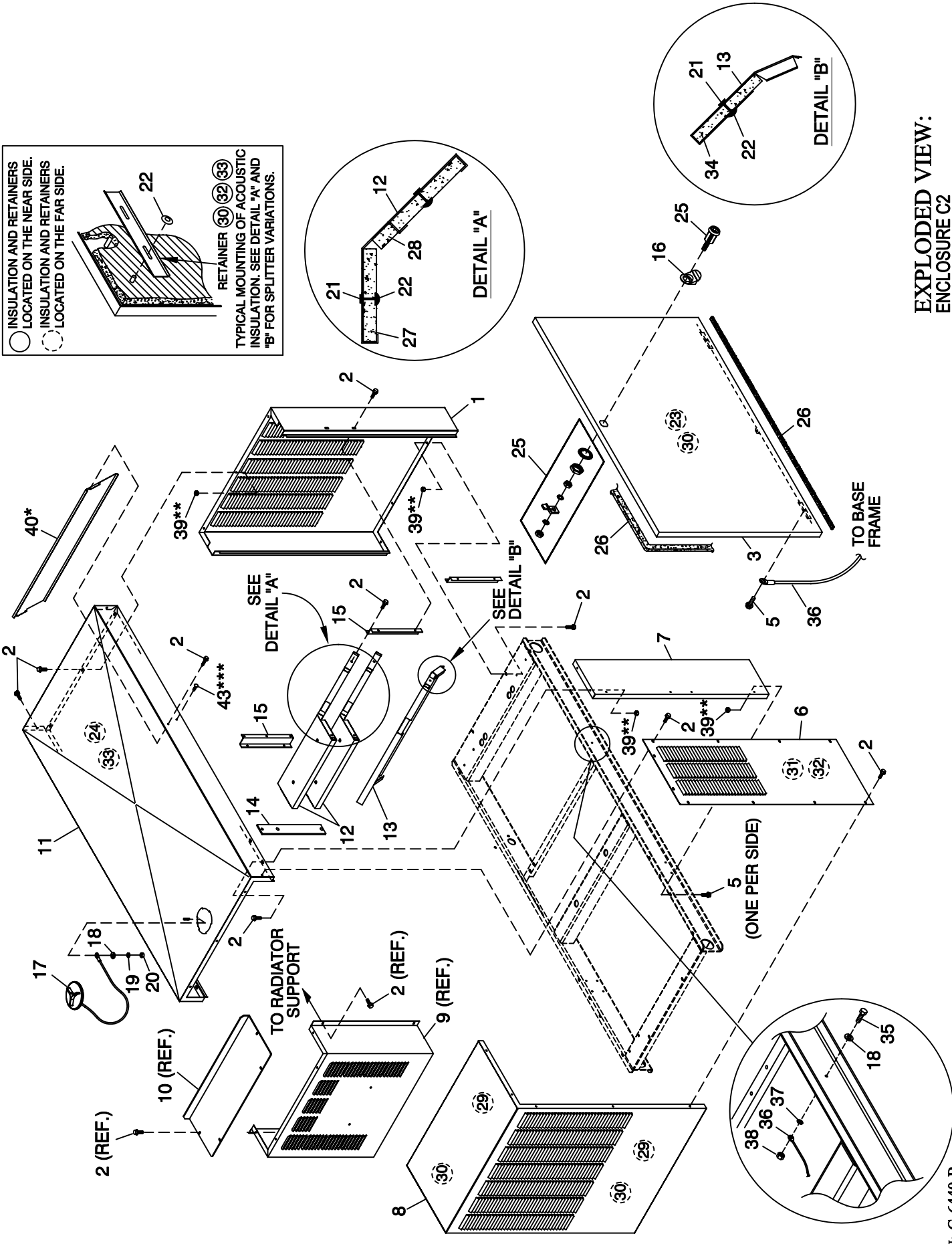

EXPLODED VIEW:
 ENCLOSURE C2
 DRAWING #: 0F7887

EXPLODED VIEW: ENCLOSURE C2

DRAWING #: 0F7887

GROUP F

APPLICABLE TO:

ITEM	PART #	QTY.	DESCRIPTION
1	0F5853 (XX)	1	REAR WRAP C2
2	0C2454	68	SCREW THF M6-1 X 16 N WA Z/JS
3	0F5849 (XX)	2	DOOR C2
4	087233	2	RIVET POP .1875 X .450 SS
5	0E3257	4	SCREW TH-FRM M6 W/CAP SHKPRF W
6	0F5852 (XX)	2	DISCHARGE DUCT,LH & RH SIDE C2
7	0F5850 (XX)	2	FRONT CORNERS C2
8	0F5851 (XX)	1	DISCHARGE CENTER DUCT C2
9	0F3313	1 (REF.)	DUCT INNER DISCHARGE C2
10	0F3312	1 (REF.)	DUCT INNER DISCHARGE TOP C2
11	0F5848	1	ROOF C2 ALUM
12	0F2786	2	SLITTER C4
13	0F2785	1	SPLITTER LOWER C4
14	0F3364	1	SPLITTER STINGER C2
15	0F4880	2	SUPPORT SPLITTER LH C2
16	0F5049	2	TAB PULL
17	0C2634A	1	ASSEMBLY COVER ACCESS
18	022473	3	WASHER FLAT 1/4-M6 ZINC
19	022097	1	WASHER LOCK M6-1/4
20	022127	1	NUT HEX 1/4-20 STEEL
21	0F3072	16	INSULATION RETAINMENT HANGER
22	078115	48	WASHER SELF LOCKING DOME
23	0F4051	2	INSULATION DOOR C2
24	0F4051A	1	INSULATION ROOF TOP
25	0F5048	2	LATCH VISE ACTION 5/16HEX SOCK
26	0E5968	1	GASKET EXTRUDED TRIM (440.64" LG)
27	0F3760K	2	INSULATION SPLITTER
28	0F3760E	2	INSULATION SPLITTER
29	0F4051C	2	INSULATION DUCT
30	0F3890B	8	RETAINER INSULATION (820)
31	0F4051B	2	INSULATION DUCT SIDES
32	0F3890	4	RETAINER INSULATION (450)
33	0F3890A	3	RETAINER INSULATION (740)
34	0F3760L	1	INSULATION LOWER SPLITTER
35	042568	2	SCREW HHC M6-1.0 X 20 G8.8
36	0912970094	2	ASSY WIRE 14 AWG 34.8" GRN/YEL
37	022447	2	WASHER SHAKEPROOF INT 1/4
38	049813	2	NUT HEX M6 X 1.0 G8 YEL CHR
39**	077992	21	NUT HEX LOCK M6-1.0 SS NY INS
40*	0F6321	1	ROOF RAIN DEFLECTOR
43***	0C3397	4	FASTENER RATCHET

OPTIONAL COMPARTMENT MATERIALS:

ALL P/N'S WITH AN (XX) SUFFIX INDICATE A MULTIPLE MATERIAL AND COLOR OPTION.
USE THE FOLLOWING LEGEND TO IDENTIFY THE CORRECT PART NUMBER:

PART NO.	MATERIAL	COLOR
0XXXXXSN	STEEL	TAN
0XXXXXAN	ALUMINUM	TAN
0XXXXXSG	STEEL	GRAY
0XXXXXAG	ALUMINUM	GRAY

* 3.9L ONLY

** ALUMINUM ENCLOSURE NOTE: ALL ENCLOSURE PANELS THAT FASTEN TO THE BASE FRAME MUST BE SECURED USING ITEM 2 & 5 THREAD FORMING FASTENER AND ITEM 39 LOCK NUT. LOCK NUT IS TO BE INSTALLED AFTER THREAD FORMING FASTENER HAS PENETRATED THROUGH EXTRUSIONS IN ENCLOSURE PANELS. ALL ROOF PANELS ARE TO BE SECURED IN THE SAME MANNER.

*** 3.0L ONLY