

# OHVI<sup>®</sup> V-Twin Engine Service Manual

GTH760/990

GTV760/990



**GENERAC<sup>®</sup>**  
POWER SYSTEMS, INC.

# FOREWORD

This manual has been written and published by GENERAC® POWER SYSTEMS, INC. to aid our dealers' mechanics, company service personnel and general consumers when servicing the products described herein.

It is assumed that these personnel are familiar with the servicing procedures for these products, or like or similar products, manufactured and marketed by GENERAC® POWER SYSTEMS, INC. It is also assumed that they have been trained in the recommended servicing procedures for these products, which includes the use of mechanics hand tools and any special tools that might be required.

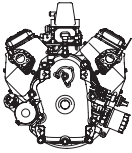
Proper service and repair is important to the safe, economical and reliable operation of the products described herein. The troubleshooting, testing, service and repair procedures recommended by GENERAC® POWER SYSTEMS, INC. and described in this manual are effective methods of performing such operations. Some of these operations or procedures may require the use of specialized equipment. Such equipment should be used when and as recommended.

We could not possibly know of and advise the service trade of all conceivable procedures or methods by which a service might be performed, nor of any possible hazards and/or results of each procedure or method. We have not undertaken any such wide evaluation. Therefore, anyone who uses a procedure or method not recommended by the manufacturer must first satisfy himself that neither his safety, nor the product's safety, will be endangered by the service or operating procedure selected.

All information, illustrations and specifications contained in this manual are based on the latest product information available at the time of publication. However, GENERAC® POWER SYSTEMS, INC. reserves the right to change, alter or otherwise improve the product at any time without prior notice.

Some components or assemblies of the product described in this manual may not be considered repairable. Disassembly, repair and reassembly of such components may not be included in this manual.

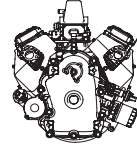
The engines described herein may be used to power a wide variety of products. Service and repair instructions relating to any such products are not covered in this manual. For information pertaining to use of these engines with other products, refer to any owner's or service manuals pertaining to said products.

**RULES FOR SAFE OPERATION****4-CYCLE ENGINE THEORY****SECTION 1: GENERAL INFORMATION****SECTION 2: IGNITION****SECTION 3: CARBURETION AND FUEL SYSTEM****SECTION 4: GOVERNOR CONTROLS AND GOVERNOR****SECTION 5: CYLINDER HEAD AND VALVES****SECTION 6: ELECTRIC STARTER****SECTION 7: ALTERNATORS****SECTION 8: LUBRICATION SYSTEM****SECTION 9: ENGINE DISASSEMBLY****SECTION 10: CYLINDER AND CRANKCASE COVER****SECTION 11: CRANKSHAFT AND CAMSHAFT****SECTION 12: PISTON, RINGS AND CONNECTING ROD INSPECTION AND ASSEMBLY****SECTION 13: ENGINE ASSEMBLY****SECTION 14: SPECIFICATIONS****1****2****3****4****5****6****7****8****9****10****11****12****13****14****A WORD ABOUT SPECIAL TOOLS**

*Many of the procedures depicted in this manual require the use of special tools. Some of the tools required are available as Generac parts and are listed as such in this manual.*

**ATTENTION!**

Generac Power Systems does not approve or authorize the use of these engines on All Terrain Vehicles (ATV's), go-carts, motorbikes, aircraft products, personal watercraft, or vehicles intended for use in competitive events. The use of this product in any other than it's intended application will void the warranty! Use of these engines in such applications could result in property damage, serious injury (including paralysis), or even death.





If you do not understand any portion of this manual, contact Generac or your nearest Generac Authorized Service Dealer for starting, operating and servicing procedures.


Throughout this publication and on tags and decals affixed to the engine, **DANGER**, **WARNING** and **CAUTION** blocks are used to alert you to special instruction about a particular operation that may be hazardous if performed incorrectly or carelessly. Observe them carefully.

These safety warnings cannot eliminate the hazards that they indicate. Strict compliance with the special instructions while performing the service plus "common sense" are major measures to prevent accidents.

The following definitions apply to **DANGER**, **WARNING**, **CAUTION** and **NOTE** blocks found throughout the manual. *These safety symbols indicate the following:*


 **DANGER:** After this heading you can read handling, installing, operating or servicing instructions that, if not strictly complied with, will result in personal injury.

 **WARNING:** After this heading you can read handling, installing, operating or servicing instructions that, if not strictly complied with, may result in personal injury.

 **CAUTION:** After this heading you can read instructions for handling, installing, operating or servicing the engine that, if not strictly complied with, may result in damage to equipment and/or property.

**NOTE:** After this heading you can read explanatory statements that require special emphasis.

These symbols indicate the following:

 Points out important safety information that, if not followed, could endanger personal safety and/or property of yourself and others.

 **Potential explosion hazard.**


 **Potential fire hazard.**

 **Potential electrical shock hazard.**

### RULES FOR SAFE OPERATION

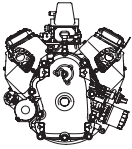
Study these RULES FOR SAFE OPERATION carefully before operating or servicing this equipment. Become familiar with the OWNER'S MANUAL and with the engine. The engine can operate safely, efficiently and reliably only if it is properly operated and maintained. Many accidents are caused by failing to follow simple and fundamental rules or precautions.

Generac cannot possibly anticipate every possible circumstance that might involve a hazard. The warnings in this manual and on tags and decals affixed to the equipment, are therefore, not all-inclusive. If you use a procedure, work method or operating technique Generac does not specifically recommend, you must satisfy yourself that it is safe for you and others. You must also make sure the procedure, work method or operating technique that you choose does not render the engine to be unsafe.

 **DANGER:** Do not tamper with the engine governed speed. High operating speeds are dangerous and increase the risk of personal injury or damage to the equipment. Operating at low speeds with heavy load may shorten the engine's life.

### BEFORE OPERATING

- Gasoline is highly **FLAMMABLE** and its vapors are **EXPLOSIVE**. Do not permit smoking, open flames, sparks or heat in the area while handling gasoline. Avoid spilling gasoline on a hot engine. Comply with all of the laws regulating storage and handling of gasoline.
- Store gasoline and other fuels only in containers designed and approved for the storage of such materials.
- Add gasoline in a clean, well-ventilated area. Wipe up any spilled gasoline immediately. If gasoline has been spilled, let it dry completely before starting the engine.
- Do not overfill the fuel tank. Always allow room for fuel expansion. If the tank is overfilled, the fuel can overflow onto a hot engine and cause a FIRE or an EXPLOSION.
- Allow at least two (2) feet of clearance on all sides of the engine, even while operating it outdoors, or you could damage the engine.
- Thoroughly inspect the engine for loose or damaged parts before each use. Do not use the engine until adjustments or repairs are made.
- Check the oil level in the engine before each use.
- Inspect the engine periodically. Repair or replace all damaged or defective parts immediately.



- Inspect fuel system frequently for leaks or damage. Repair or replace any damaged or leaking component immediately. Never attempt to change, alter or modify the engine fuel system in any way that might affect safety or compliance with applicable codes and standards.

### WHILE OPERATING

- This engine was designed and manufactured for specific applications. Do not attempt to modify the equipment or use it for any application for which it was not designed.
- Generac Power Systems does not approve or authorize the use of these engines on All Terrain Vehicles (ATV's), go-carts, motorbikes, aircraft products, personal watercraft, or vehicles intended for use in competitive events. The use of this product in any other than it's intended application will void the warranty! Use of these engines in such applications could result in property damage, serious injury (including paralysis), or even death.
- Engine exhaust gases contain DEADLY carbon monoxide gas. This dangerous gas, if breathed in sufficient concentrations, can cause unconsciousness or even death. Operate this equipment only in the open air where adequate ventilation is available.
- Do not insert any object through the cooling slots of the engine. You could damage the equipment or injure yourself.
- Do not operate the engine faster than the speed necessary to operate the equipment. Do not run the engine at high speed when not operating the equipment.
- This engine requires an adequate flow of cooling air for its continued proper operation. Never operate the equipment inside any room or enclosure where the free flow of cooling air into and out of the equipment might be obstructed. Without sufficient cooling air flow, the engine quickly overheats, damaging the engine or nearby property.
- Do not smoke around the engine. Wipe up any fuel or oil spills immediately. Never leave oily or fuel soaked rags around the engine. Keep the area around the engine clean and free of debris.
- Keep hands, feet, clothing, etc., away from moving parts of this engine.
- Never operate the engine (a) in the rain; (b) in any enclosed compartment; (c) if the engine speed changes; (d) if the engine sparks; (e) if flame or smoke is observed while the engine is running.
- Never work on this engine or handle any electrical device while standing in water, while barefoot, or while hands or feet are wet. DANGEROUS ELECTRIC SHOCK will result.



## WARNING:



The engine exhaust from this product contains chemicals known to the State of California to cause cancer, birth defects, or other reproductive harm.

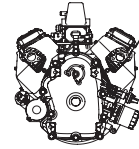
## SERVICE INFORMATION

Service on this engine within and after the warranty period can be performed by any authorized service dealer. Service technicians are factory trained and capable of handling all service needs.

When contacting an authorized service dealer about parts and service, **always supply the complete model number and serial number** of your unit as given on its data plate decal. See the illustration below for the location of the decal.

The warranty for this engine is included in the owner's manual.

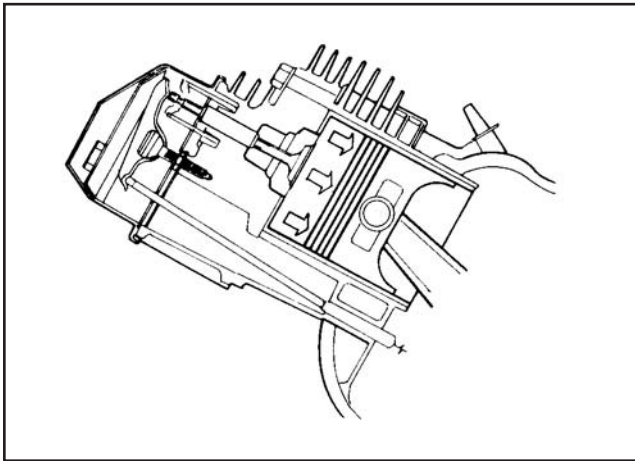




If the engine is to run properly, four (4) events must occur in the proper sequence and at the correct time. These events are (A) intake, (B) compression, (C) ignition and power, and (D) exhaust.

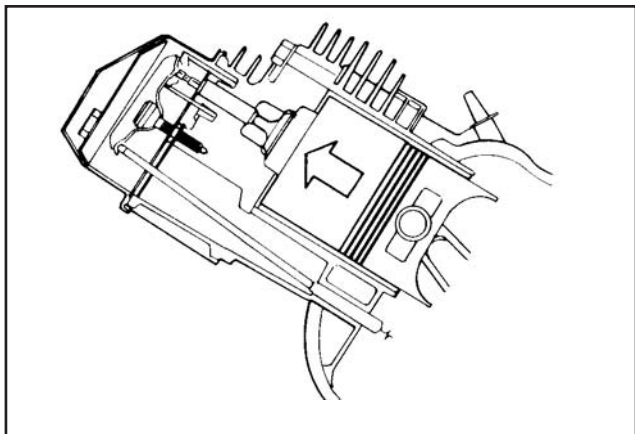
### (A) INTAKE

The piston is travelling from top dead center (TDC) to bottom dead center (BDC). The cam has opened the intake valve. The piston's downward movement in the cylinder creates a partial vacuum in the cylinder. Air at atmospheric pressure is drawn into the cylinder through the carburetor and is mixed with fuel in the carburetor. The fuel-air mixture flows through the open intake valve into the cylinder. When the piston reaches BDC, the intake stroke is over.



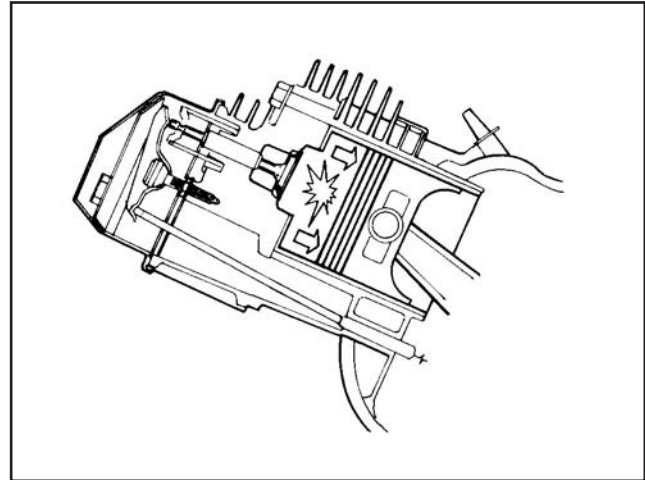
### (B) COMPRESSION

As the piston reaches bottom dead center (BDC), both the intake and exhaust valves are closed. The piston moves upward toward TDC and the fuel-air mixture is compressed. Just before the piston reaches TDC, ignition occurs.



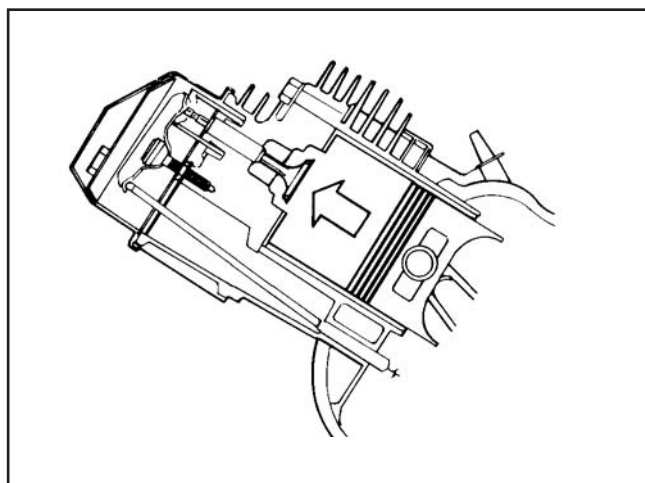
### (C) IGNITION AND POWER

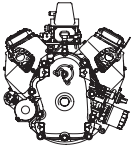
By the time the piston reaches TDC, combustion is already in progress. The intake and exhaust valves remain closed as the expanding gases of combustion force the piston downward.



### (D) EXHAUST

The exhaust stroke begins when the piston has reached BDC and has started its upward movement. The intake valve is closed. The exhaust valve is open to let gases escape.





**MAINTENANCE SCHEDULE**

	Every 8 Hours or Daily	Every 25 Hours Season	Every 50 Hours Season	Every 100 Hours Season
Check Oil Level	•			
Change Oil				Note 1
Change Oil Filter				Note 1
Service Air Filter		Foam Pre-Filter if equipped	Filter (Note 2)	
Replace or Clean Spark Plug				•
Clean Spark Arrestor Screen				•
Valve Clearance				Note 3

**NOTE 1:** Change oil and filter after first 8 hours of operation and then every 100 hours thereafter. Change sooner when operating under a heavy load or in a dusty or dirty environment or in high ambient temperature.

**NOTE 2:** Clean more often when operating in dirty or dusty conditions. Replace canister style filter every 500 hours.

**NOTE 3:** Check valve lash and adjust if necessary after first 50 hours of operation and every 100 hours thereafter.

**FUEL AND OIL RECOMMENDATIONS**

GASOLINE:

We recommend the use of clean, fresh lead-free gasoline. A minimum of 85 octane is recommended. The use of lead-free gasoline results in fewer combustion deposits and longer valve life.

**NOTE:** Using a fuel additive such as STA-BIL® fuel stabilizer, or an equivalent, will prevent gum deposits from forming in the engine's fuel system.

**NOTE:** Some fuels, called oxygenated or reformulated gasolines, are gasolines blended with alcohols, ethers or ethanol. Excessive amounts of these blends can damage the fuel system or cause performance problems. Do not use gasoline which contains Methanol. If any undesirable operating symptoms occur, use gasoline with a lower percentage of alcohol, ether or ethanol.

It is also recommended that gasoline be purchased in small quantities, not more than a 30 day supply. FRESH gasoline minimizes gum deposits, and also will ensure fuel volatility tailored for the season in which the engine will be operated.

LUBRICATION:

Oil has four purposes. It cools, cleans, seals and lubricates. During normal operation, small particles of metal from the cylinder walls, pistons, bearings and combustion deposits will gradually contaminate the oil. Dust particles from the air also contaminate the oil forming an abrasive mixture which can cause wear to all of the internal moving parts of the engine, if the oil is not changed regularly. Fresh oil also assists in cooling. Old oil gradually becomes thick and loses its cooling ability as well as its lubricating qualities.

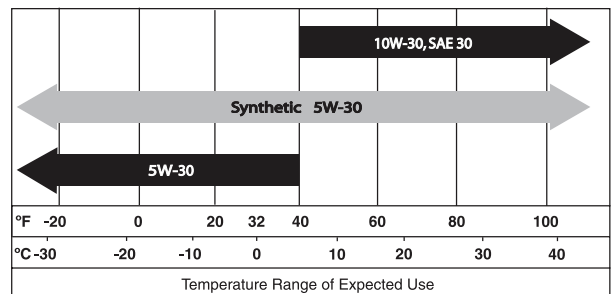
RECOMMENDED OIL TYPE:

Using the proper type and weight of oil in the crankcase is extremely important. Check the oil before each use and change the oil regularly (see Figures 1-1 through 1-5). Failure to use the correct oil, or using dirty oil, can cause premature engine wear and failure.

Use only high quality detergent oil rated with an API service classification SJ or higher (example: SL or SM). Do NOT use oil designated "for diesel engines only" (example: CD).

The recommended oil weights include the following:

- During summer months: SAE 30. An acceptable substitute is SAE 10W-30. After first oil change, synthetic oil is acceptable.
- During winter months: SAE 5W-30 or synthetic 5W-30. DO NOT USE SAE 10W-40. After first oil change, synthetic oil is acceptable.

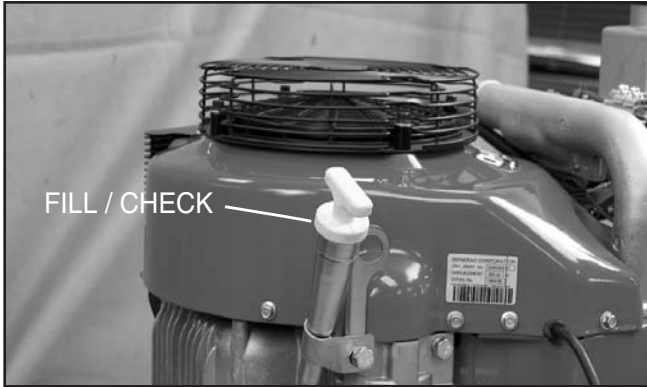
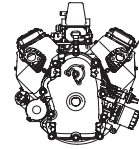


CHANGE OIL:

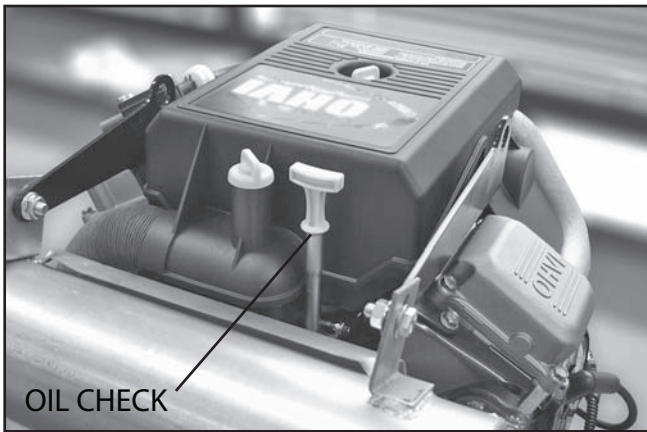
See "Section 14: Specifications" for crankcase oil capacities. Use no special additives. Make sure that the unit is level when filling with oil. DO NOT OVERFILL.

**IMPORTANT: DO NOT OVERFILL. Check and maintain oil level regularly. Change oil and filter after first eight (8) hours of operation.**

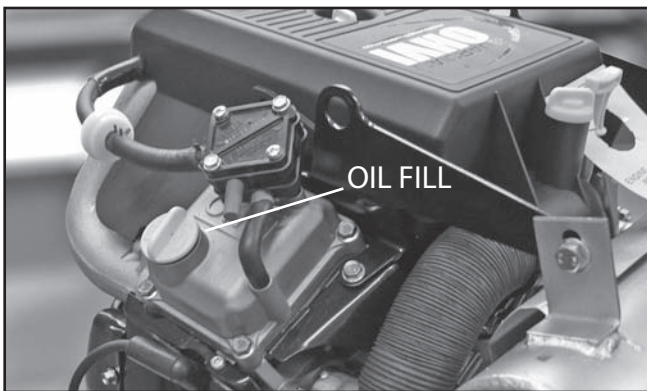
Thereafter, change oil and filter every 100 hours of operation. Change oil more often if engine is operated in dirty or dusty conditions or if engine is operated under heavy loads or in high ambient air temperatures.



**Figure 1-1. Oil Fill/Check Vertical Engine**



**Figure 1-2. Oil Check Horizontal Engine**



**Figure 1-3. Oil Fill Horizontal Engine**

Remove oil drain plug and drain oil while engine is still warm, Figure 1-4. Change oil filter (Figure 1-5) and replace drain plug.

Remove dipstick and refill slowly with new oil of proper service classification and viscosity grade. Refill to full mark on dipstick. When checking oil level, dipstick must be all the way in for accurate readings.

CHANGE OIL FILTER:

Replace oil filter every 100 hours. Before installing new filter, lightly oil filter gasket with fresh clean engine oil. Screw filter on by hand until gasket contacts filter adapter. Tighten 3/4 to one full turn farther, Figure 1-5.

Start and run engine at idle for 30 seconds and stop engine. Recheck oil level and add if required. Restart engine and check for oil leaks.



**Figure 1-4. Oil Drain**

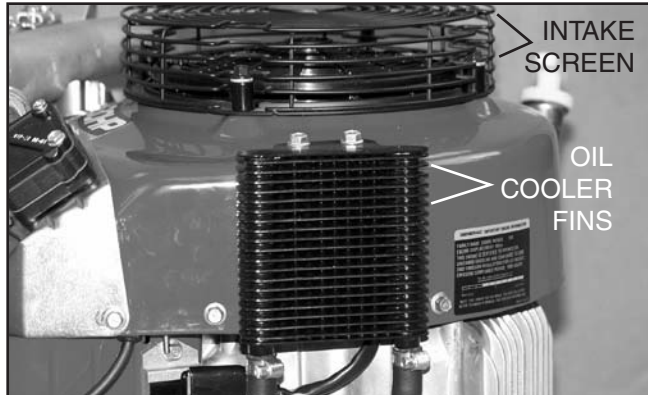
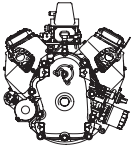


**Figure 1-5. Oil Filter**

CLEANING INTAKE SCREEN:

Grass particles, chaff or dirt can clog the air cooling system, especially after prolonged service in cutting dry grass or when operating in extremely dusty or dirty conditions. Continued operation with a clogged cooling system can cause severe overheating and possible engine damage. Figure 1-6 shows the areas to be cleaned. This should be a regular maintenance operation, or clean intake screen and oil cooler fins after each use.

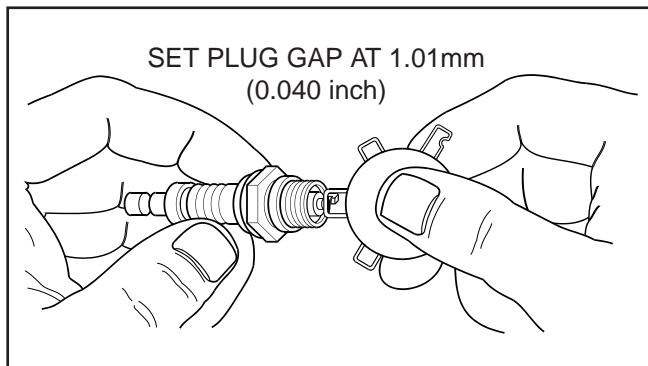




**Figure 1-6. Clean Intake Screen & Oil Cooler Fins**

REPLACE SPARK PLUGS:

Replace spark plugs every 100 hours of operation or every season, whichever occurs first. Replace spark plugs if electrodes are burned away, or the porcelain is cracked. Set spark plug gap at 1.01 mm (0.040") for all models. Torque spark plugs to 19.0 Nm (168 in. lbs.).



**Figure 1-7. Setting Spark Plug Gap**

**Note: For proper spark plug replacement, refer to the owner's manual for the specific product.**

AIR CLEANER MAINTENANCE:

**⚠ WARNING: NEVER OPERATE ENGINE WITH AIR CLEANER ASSEMBLY OR AIR CLEANER CARTRIDGE REMOVED. FIRE MAY RESULT.**

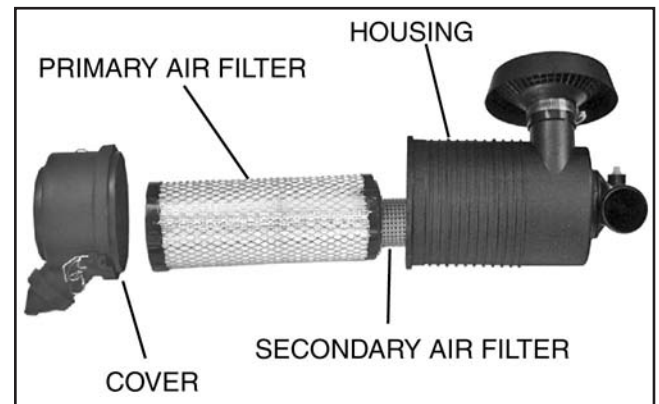
A properly serviced air cleaner protects internal parts of the engine from dirt and dust particles in the air. If air cleaner instructions are not carefully followed, dirt and dust which should be collected in the cleaner will be drawn into the engine. These particles are highly abrasive and will cause the piston rings and cylinder bore to wear quickly. As the rings and cylinder bore become worn, these abrasive particles enter the crankcase and contaminate the oil, forming an abrasive mixture which will cause wear on all of the internal moving parts.

The air cleaner on every engine brought in for a check up or repair should be examined and serviced. If the air cleaner shows signs of neglect, show it to the customer before cleaning. Instruct the customer on proper care, to assure long engine life.

**Note: Replace air cleaner gaskets and mounting gaskets that are worn or damaged, to prevent dirt and dust from entering engine due to improper sealing. Replace bent air cleaner mounting bracket if necessary.**

SERVICE CANISTER AIR CLEANERS:

Clean the air filter element(s) with compressed air every 50 hours or every season, whichever occurs first. Replace the air filter element(s) every 500 hours or if damaged (see Figure 1-8).



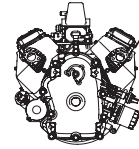
**Figure 1-8. Canister Air Cleaner Components**

SERVICE DUAL ELEMENT AIR CLEANERS:

Remove and service foam pre-cleaner every 25 hours or every season, whichever occurs first. Service cartridge every 50 hours or every season, whichever occurs first (see Figure 1-9).



**Figure 1-9. Dual Element Air Cleaner Components**



**Note:** *The air cleaner assemblies on some equipment may have been supplied by the equipment manufacturer. See the equipment manufacturer's owner's manual for service information specific to that product.*

**TROUBLESHOOTING**

Most complaints concerning engine operation can be classified as one or a combination of the following:

1. Will not start
2. Hard starting
3. Lack of power
4. Runs rough
5. Vibration
6. Overheating
7. High oil consumption

**Note:** *What appears to be an engine malfunction may be a fault of the powered equipment rather than the engine. If equipment is suspect, see equipment affecting engine operation.*

**SYSTEMATIC CHECK**

If the engine will not start and the cause of malfunction is not readily apparent, perform a systematic check in the following order:

1. Fuel
2. Ignition
3. Compression

This check-up, performed in a systematic manner, can usually be done in a matter of minutes. It is the quickest and surest method of determining the cause of failure. The basic checkup procedure is the same for all engine models, while any variation, by model, will be shown under the subject heading.

CHECK FUEL:

The fuel pressure on LP and NG generator engines can be checked using a pressure tester kit for LP and NG systems.

For gasoline engines, check the following:

1. Are the tanks full?
2. Is the fuel stale?
3. Is the tank vent open?
4. Is the fuel shutoff valve open?
5. Is the fuel pump working?
6. Is the fuel solenoid working?

CHECK IGNITION:

If spark does not occur look for:

- Shorted ignition/ground wire (see Page 2-1)
- Two closed diodes in ground wire harness (see Page 2-1)
- Incorrect ignition coil air gap (see Page 2-3)
- Ignition coil failure

CHECK IGNITION (ENGINE RUNNING):

If engine runs but misses during operation, a quick check to determine if ignition is or is not at fault can be made by installing a spark tester (Generac P/N 0C5969) between the spark plug lead and each spark plug, Figure 1-10. A spark miss will be readily apparent when the engine is running. If spark is good but engine misses, check for a fouled spark plug.



**Figure 1-10. Running Check**

CHECK IGNITION (FOULED PLUG OR OTHER CAUSES):

To check for a fouled spark plug or a non-functioning cylinder, attach the spark tester (Generac P/N 0C5969) between the spark plug lead and each spark plug. Start and run engine at top no load speed. Now ground one spark plug, Figure 1-11. The engine should continue to run on the other cylinder. Repeat this test with the other cylinder. If the engine will not continue to run when making this test, the cylinder that is NOT grounded is not functioning and/or the spark plug is fouled. Install a new spark plug before proceeding. If miss continues, problem may be carburetion or compression. See Check Fuel, Check Compression, and Cylinder Balance Test.

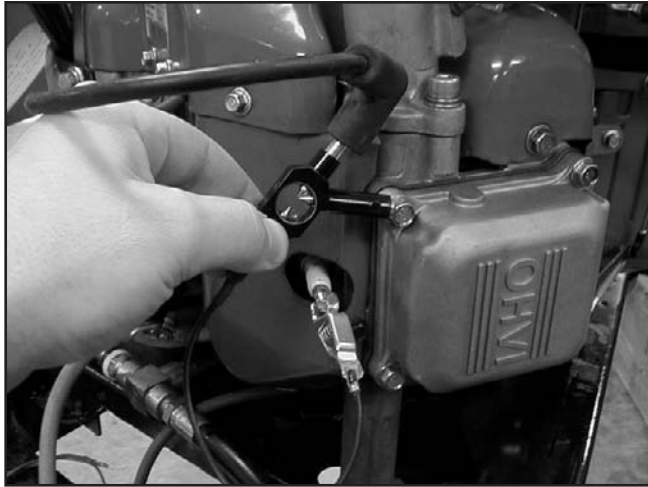
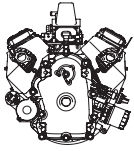


Figure 1-11. Checking For Fouled Plugs

CYLINDER BALANCE TEST:

If the engine is hard starting, runs rough, misses or lacks power, perform a cylinder balance test to determine whether both cylinders are operating to their full potential.

Tools Required:

- Two Ignition Testers (Generac P/N 0C5969)

Attach an ignition tester between the spark plug lead and each spark plug, Figure 1-10.

Start and run engine at top no load speed and note spark at ignition testers. If the spark is equal at both ignition testers, the problem is not ignition related. A spark miss will be readily apparent. Now note RPM of engine. Ground out one cylinder by contacting ignition tester and a good ground on engine, Figure 1-11. Note RPM loss. Then ground out the other spark plug and note the RPM loss. If the difference between the two cylinders does not exceed 75 RPM, the amount of work the two cylinders are doing should be considered equal.

If the RPM loss is greater than 75 RPM this indicates that the grounded cylinder with the least RPM loss is the weakest of the two cylinders. Look to that cylinder for a problem.

Example:

Engine RPM - Both Cylinders = 3400 RPM

Engine RPM - #1 Cylinder Grounded = 3300 RPM

Engine RPM - #2 Cylinder Grounded = 3100 RPM

Conclusion: #1 cylinder is weakest of the two cylinders.

The cylinder balance test will also detect a cylinder that is not functioning. When grounding out one cylinder there will be no RPM loss. When the other cylinder is grounded out the engine will stop.

CHECK COMPRESSION:

It has been determined through testing that a simple and accurate indication of compression can be made as follows:

Remove both spark plugs and insert a compression gauge into either cylinder (one cylinder at a time). Open the throttle to Wide Open Throttle (WOT) position. Turn engine over with engine starter until there is no further increase in pressure. Record this reading. Repeat procedure on other cylinder and record that reading. The difference between both cylinders should not exceed 25%. More than 25% indicates loss of compression in the cylinder with lower pressure. See example.

EXAMPLE:

	Cyl. #1	Cyl. #2	Diff.
Eng. #1	165 PSI	160 PSI	5 PSI
Eng. #2	175 PSI	155 PSI	20 PSI

If compression is poor, look for:

- Insufficient valve clearance
- Loose cylinder head bolts
- Blown head gasket
- Burned valves, valve seats and/or loose valve seats
- Warped cylinder head
- Warped valve stems
- Worn bore and/or rings
- Broken connecting rods

Model	Normal Compression
GTH/GTV-760	130-160 psi
GTH/GTV-990	160-190 psi

**CYLINDER LEAKDOWN TEST**

A cylinder leak down test will indicate the condition of the cylinder. It will assist in troubleshooting the engine's condition such as leaking valves or rings.

On the tester there will be two gauges, one will be the incoming air pressure and the other will measure the percent of cylinder leakage (see Figure 1-12).

CYLINDER LEAK DOWN TEST PROCEDURE:

- Piston must be at TDC.
- Install the tester into the spark plug hole.
- The crankshaft/flywheel must be safely locked down to prevent turning.
- Pressurize the cylinder to 90 psi.
- Observe the leakage of the cylinder and where the air is coming from.

**NOTE: If leaking into intake or exhaust port, check lash, valve face, and seat condition.**

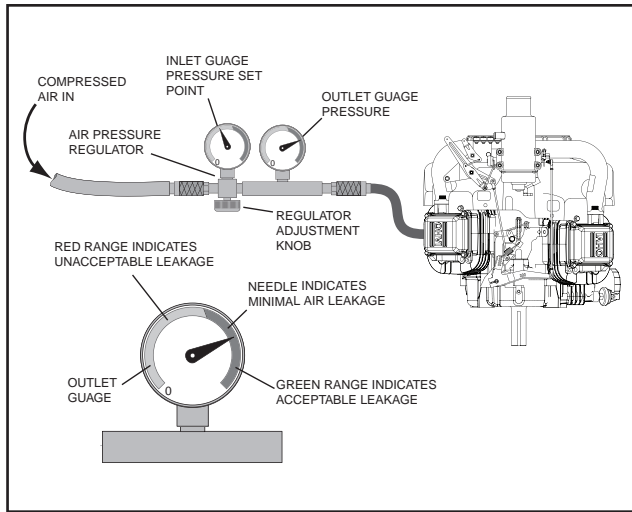
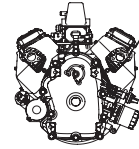


Figure 1-12. Cylinder Leakdown Tester

RESULTS:

1. 0-10% Cylinder is good
2. 10-30% there may be a problem
3. 30-100% Cylinder requires repair

THINGS WHICH AFFECT BOTH CYLINDERS:

1. Carburetion
2. Crankcase vacuum
3. Ignition timing
  - a. A partially sheared flywheel key will effect ignition timing and engine performance.

THINGS WHICH AFFECT ONE CYLINDER:

1. Spark plug
  - a. A fouled spark plug may indicate that carburetor is out of adjustment.
2. Leak in spark plug wire
3. Head gasket
4. Intake manifold
  - a. A leak at either end of the intake manifold will only affect one cylinder, not both.
5. Valves
6. Rings
7. Piston
8. Cylinder

**NOTE:** A twin cylinder engine will run well on one cylinder as long as the power required for the application does not exceed the power produced by the one cylinder.

**EQUIPMENT AFFECTING ENGINE OPERATION**

Frequently, what appears to be a problem with engine operation, such as hard starting, vibration, etc., may be the fault of the equipment powered rather than the engine itself. Listed are the most common effects of equipment problems, and what to look for as the most common cause.

HARD STARTING OR WILL NOT START:

1. Loose belt - a loose belt like a loose blade can cause a backlash effect, which will counteract engine cranking effort.
2. Starting under load - see if the unit is disengaged when engine is started; or if engaged, should not have a heavy starting load.
3. Check remote control assembly for proper adjustment.
4. Check interlock system for shorted wires, loose or corroded connections, or defective modules or switches.

ENGINE WON'T STOP:

1. Check equipment ignition stop switch.
2. Check for loose or disconnected equipment stop switch wire.
3. Check ground wire harness on engine.
  - a. See Section 2 for test procedure.

VIBRATION:

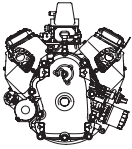
1. Unit load out of balance - remove and balance.
2. Mounting bolts loose - tighten.

POWER LOSS:

1. Bind or drag in unit- if possible, disengage engine and operate unit manually to feel for any binding action.
2. Unit load has excess drag.

NOISE:

1. Engine coupling or pulley - an oversize or worn coupling can result in knocking, usually under acceleration. Check for fit or tightness.
2. Equipment needs lubrication.



**GENERAL INFORMATION**

Generac GTH/GTV-760/990 OHVI V-Twin engines use a magneto ignition: an ignition coil with a self-contained transistor module (no moving parts). Two magneto ignition coils are used, with a flywheel containing a permanent magnet.

**NOTE: The magneto ignition system requires a minimum of 250 RPM to produce a consistent spark.**

**ENGINE WIRING HARNESS**

The engine wiring harness consists of a ground wire with a diode for each ignition coil and a separate wire for the carburetor solenoid. The engine ground wires are connected to the wiring harness provided by the equipment manufacturer.

**NOTE: Newer models will have the diodes built into the ignition coils or spark plug leads. Check the wire harness. If there are no diodes in the harness, perform test on the coil ground terminal.**

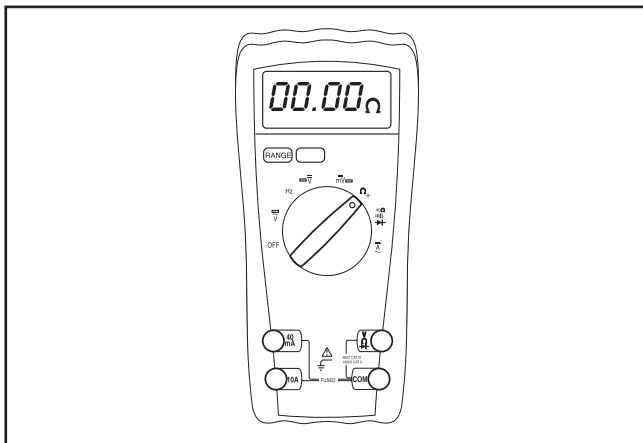
See Figure 2-4.

TESTING GROUND WIRES:

Use a Digital Multimeter (Figure 2-1) to test the ground wires.

The following test will be made with the meter in the Diode Test position.

In the Diode Test position, the meter will display the forward voltage drop across the diode(s). If the voltage drop is less than 0.7 volts, the meter will "Beep" once as well as display the voltage drop. A continuous tone indicates continuity (shorted diode) An incomplete circuit (open diode) will be displayed as "OL."

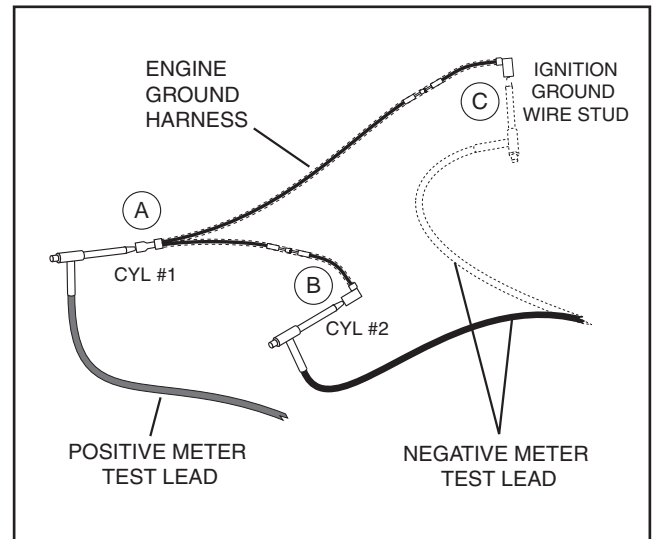


**Figure 2-1. Digital Multimeter**

1. Insert RED test lead into **VΩ** receptacle in meter.
2. Insert BLACK test lead into the "COM" receptacle in meter.

3. Rotate selector to **▶|** (Diode Test) position.
4. Insert RED test lead clip into connector "A" (Figure 2-2). Leave attached for remainder of test.
5. Touch BLACK test lead probe to terminal "B."
  - a. If meter "Beeps" once, diode is OK.
  - b. If meter makes a continuous tone, diode is defective (shorted). Replace ground harness.
  - c. If meter displays "OL," diode is defective (open). Replace ground harness.
6. Now repeat test for terminal "C." Results must be the same.
7. Replace wiring if defective.
8. If wiring tests good, proceed to IGNITION COILS section to replace defective coil.

**Note: See "Diode Failure Diagnosis", Figure 2-3.**



**Figure 2-2. Testing Ground Wire**

SWITCH ON	TURNT OFF	CAUSE
Engine Runs On 1 Cylinder	Shuts Off OK	1 Closed Diode
Engine Runs (Both Cylinders)	Only One Cylinder	1 Open Diode
Won't Run (No Spark)		2 Closed Diodes
Engine Runs (Both Cylinders)	Engine Won't Shut Off	2 Open Diodes

**Figure 2-3. Diode Failure Diagnosis**

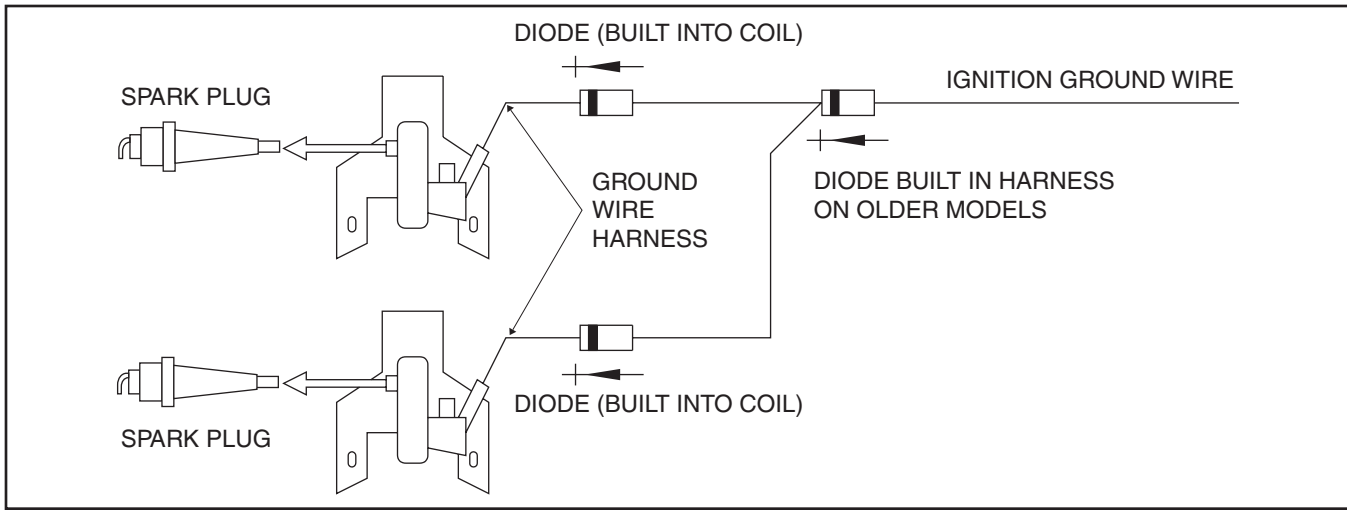
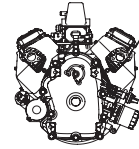


Figure 2-4. Engine Wiring Harness

**WIRE HARNESS CHECK**

IGNITION COIL TESTING:

If ignition does not have spark, disconnect ground wire from ignition ground stud on engine and re-check. If ignition now has spark, check wire harness for pinched wires, broken insulation or bad diode (if equipped). If there is no spark, proceed to Removing Ignition Coil section.

REMOVING AND INSTALLING WIRE HARNESS:

1. Remove spark plug leads.
2. Remove intake manifold and cover intake ports with a shop towel.
3. Remove rotating screen and blower housing.
4. Disconnect stop switch wire(s) at ignition coil(s).
5. Reverse order of above to install new wire harness.

REMOVING IGNITION COILS:

The condition of the ignition coils can be accurately diagnosed using an ignition spark tester (Generac P/N 0C5969) as described in "TROUBLESHOOTING" Section 1.

1. Remove spark plug leads.
2. Remove intake manifold and cover intake ports with a shop towel.
3. Remove rotating screen and blower housing.
4. Disconnect stop switch wire(s) at ignition coil(s).
5. Remove ignition coil screws and lift of ignition coil(s). See Figure 2-5.

**Note:** The flywheel does not need to be removed to service ignition except to check the flywheel key.

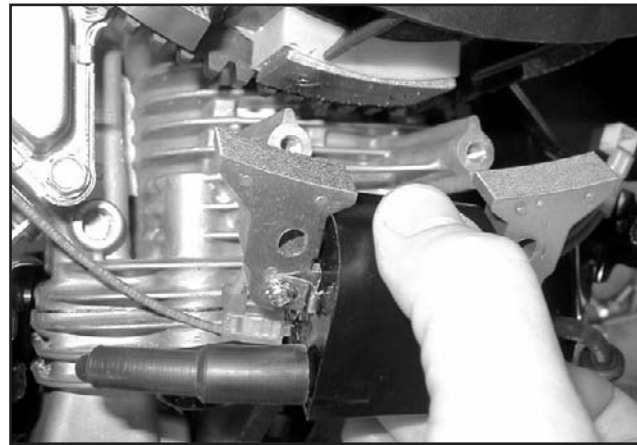


Figure 2-5. Removing Ignition coil

INSTALL IGNITION COILS:

1. Turn flywheel so magnet is away from ignition coil.
2. Install ground wire onto tab terminal on ignition coil.

**Note:** Make sure wires are routed over ignition coil mounting posts and away from flywheel.

3. Assemble ignition coil to engine, Figure 2-6.
  - a. Mounting holes in ignition coil are slotted. Push ignition coil away from flywheel as far as possible and tighten screws.
4. Repeat for second ignition coil.
5. See Adjust Ignition Coil Air Gap.

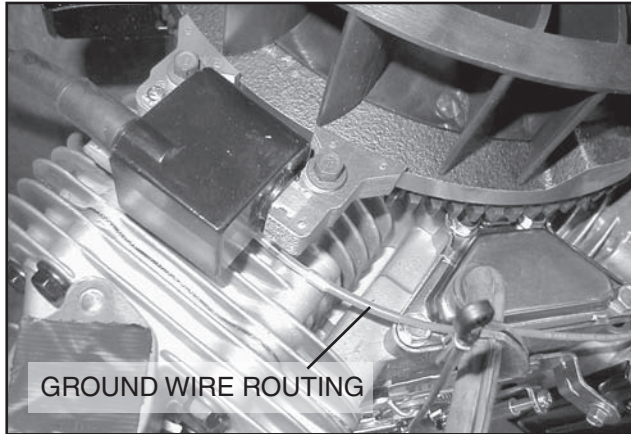
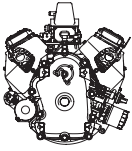


Figure 2-6. Installing Ignition coil

ADJUST IGNITION COIL AIR GAP:

1. Rotate flywheel until magnet is under ignition coil laminations.
2. Place 0.20-.30 mm (.008"-.012") thickness, non-magnetic gauge between magnet and ignition coil laminations, Figure 2-7.
3. Loosen mounting screws so magnet will pull ignition coil down against thickness gauge.
  - a. Torque screws to 4.75 Nm (40 in. lbs.).

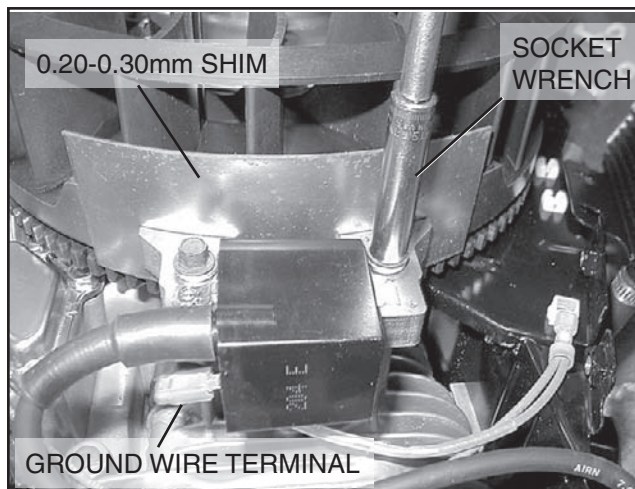


Figure 2-7. Adjusting Air Gap

4. Rotate flywheel to remove thickness gauge.
5. Repeat for second ignition coil.

**Note:** Route ignition coil ground wire under breather tube and away from the flywheel (see Figure 2-9).

**FLYWHEEL**

REMOVE FLYWHEEL:

1. Remove two screws that attach fan and fan retainer to flywheel.
2. Remove fan retainer and fan.
3. Remove flywheel nut and washer, Figure 2-8.
4. Reinstall flywheel nut. Turn nut down flush with top of threads.
5. Install flywheel puller.
6. Tighten puller screws equally until flywheel loosens, Figure 2-9.

2

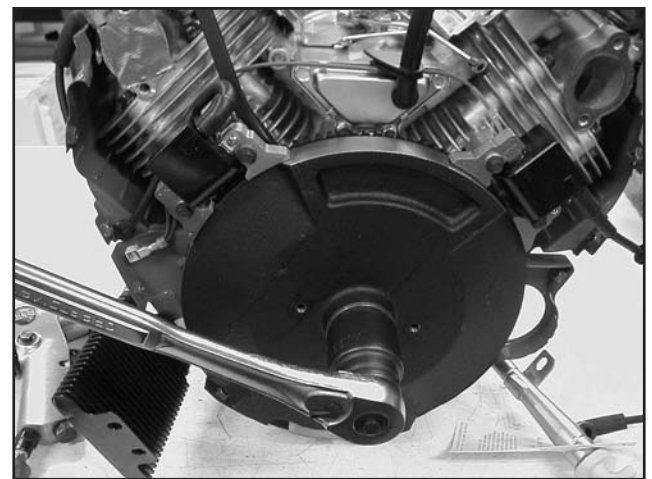


Figure 2-8. Removing Flywheel Nut

**Caution:** Flywheel puller bolts may damage lighting coil if turned in too far.

**Caution:** DO NOT strike flywheel with a hard object or a metal tool as this may cause flywheel to shatter in operation. Always use approved flywheel removal tools.

INSPECT FLYWHEEL KEY, KEYWAYS, FLYWHEEL AND CRANKSHAFT:

Check flywheel key for damage. Check flywheel for cracks or keyway damage. Also check crankshaft keyways and taper for damage, Figure 2-10. Replace crankshaft, if damaged.

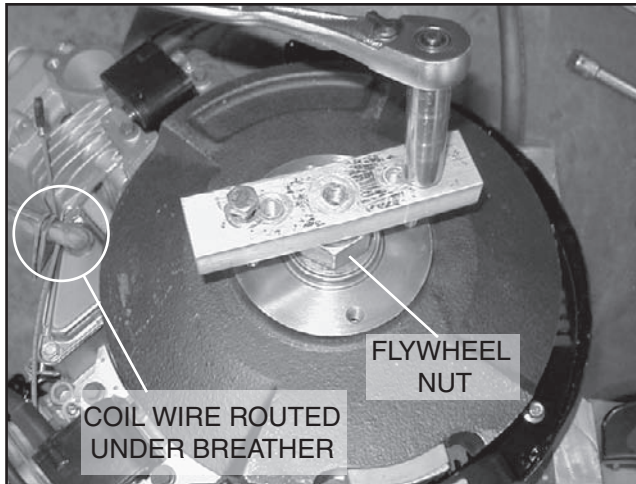
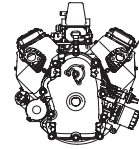


Figure 2-9. Removing Flywheel

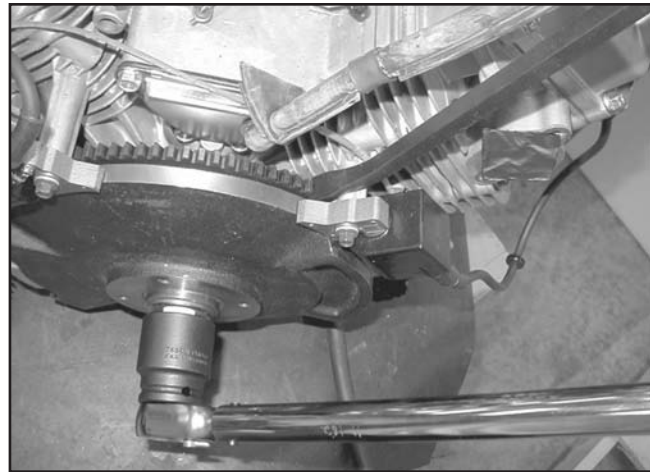


Figure 2-11. Torquing Flywheel Nut

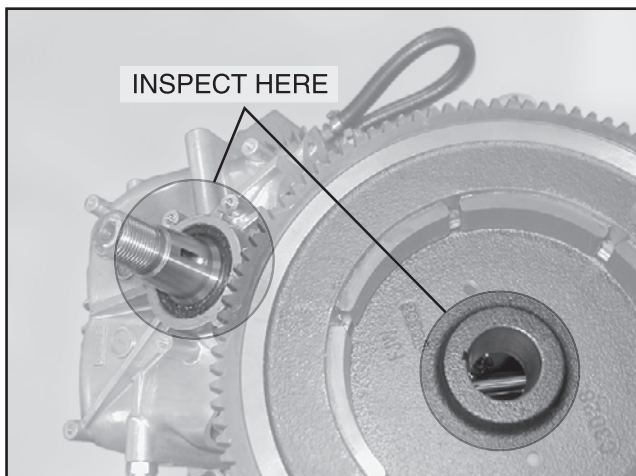


Figure 2-10. Check Flywheel And Crankshaft

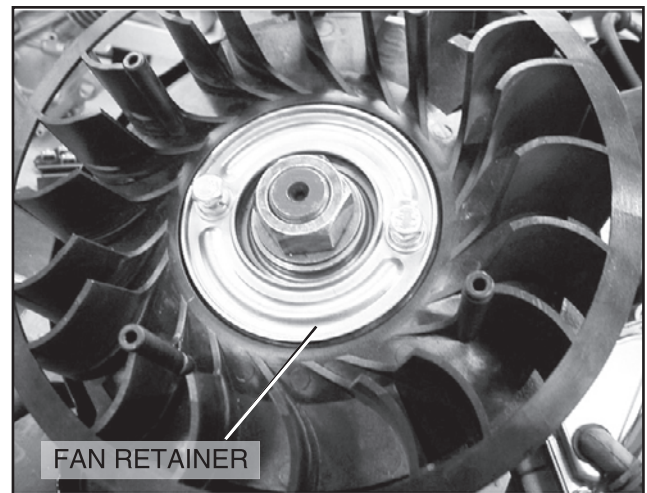


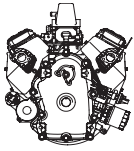
Figure 2-12. Installing Flywheel And Fan

INSTALL FLYWHEEL:

**Note: CLEAN flywheel and crankshaft taper removing all oil, dirt or grease.**

1. Insert flywheel key into crankshaft.
2. Align keyways and assemble flywheel to crankshaft.
3. Install washer and flywheel nut.
  - a. Torque flywheel nut to 204.0 Nm (150 ft. lbs.), Figure 2-11.
4. Assemble fan and retainer to flywheel, Figure 2-12.
  - a. Torque screws to 21.7 Nm (182 in. lbs.).





**CARBURETOR TYPES**

All Generac OHVI V-Twin engines utilize a two-barrel type carburetor.

**CARBURETOR REMOVAL - VERTICAL SHAFT**

1. Unclip choke link from bellcrank and remove link from carburetor.
2. Disconnect fuel-shutoff solenoid by unbolting the ground wire from the manifold and unplugging the power wire. On some models, both wires unplug from the solenoid.
3. Disconnect breather tube.
4. Separate throttle link balljoint from carburetor by rotating the ball socket.
5. Disconnect the fuel line clamp and the fuel line.

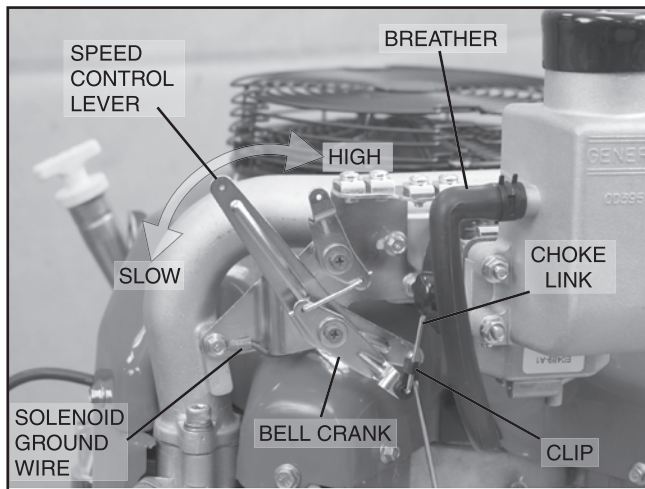


Figure 3-1. Vertical Shaft Carburetor

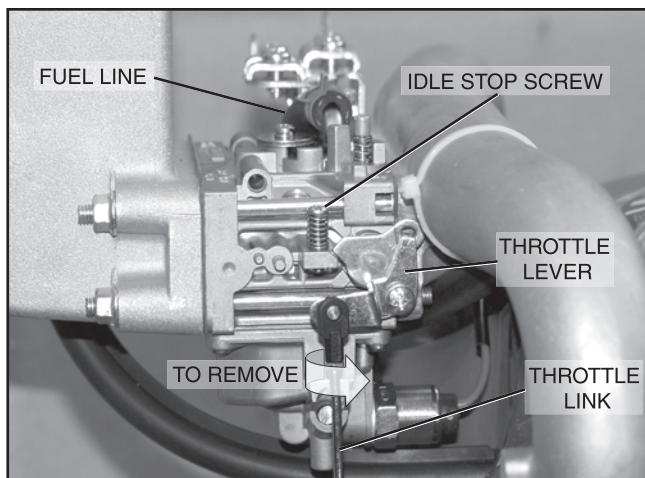


Figure 3-2. Vertical Shaft Carburetor

6. Remove the four nuts holding the carburetor and plenum to the intake manifold (see Figure 3-6).
7. Remove the plenum, carburetor and gaskets from the manifold and discard the gaskets.

**CARBURETOR REMOVAL – HORIZONTAL SHAFT**

1. Remove air cleaner cover and air cleaner.
2. Unthread yellow plastic knob from Summer/Winter intake control (if equipped)
3. Remove dipstick tube hold down bolt and remove tube assembly (see Figure 3-3).
4. Remove the four nuts and one bolt that retains the air cleaner base; remove base (see Figure 3-3).
5. Remove fuel line clamp and fuel line from top of carburetor.

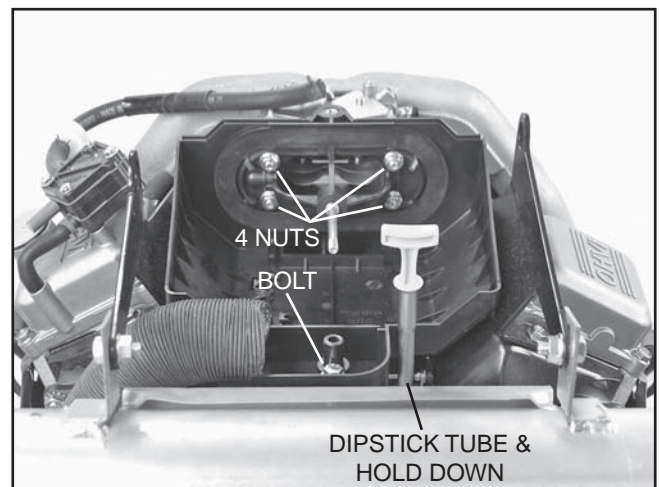


Figure 3-3. Horizontal Shaft Carburetor



Figure 3-4. Horizontal Shaft Carburetor

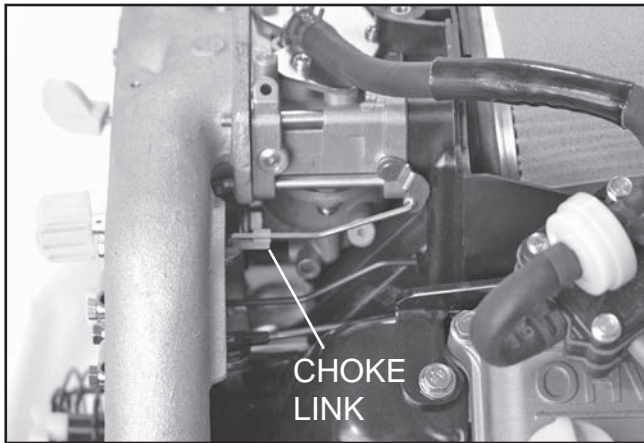
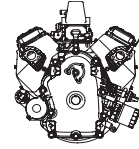


Figure 3-5.

6. Remove choke link (Figure 3-5), throttle link (Figure 3-4) and fuel shut-off solenoid wire from carburetor.
7. Slide carburetor off mounting studs.

### CARBURETOR CLEANING

For cleaning purposes, the carburetor's float bowl may be removed. It is recommended that all jetting be left in place while cleaning the carburetor. Be sure to use a cleaner that won't damage rubber, neoprene, or plastic parts.

**Note: The left and right main jets are different sizes.**

If the fuel-shutoff solenoid is suspected of being faulty, it is replaceable by simply unthreading it from the float bowl, and installing a new one in its place. It can be checked by applying 12 volts to it. If you hear it click, it is most likely working properly. If there is anything else wrong with the carburetor, it is recommended that the entire carburetor be replaced with a new one.

**Note: Be careful not to lose the spring that is located inside the fuel shutoff solenoid when removing the plunger.**

### CARBURETOR INSTALLATION - VERTICAL SHAFT

1. Slide new carburetor gasket and carburetor onto the studs.
2. Slide new plenum gasket and plenum onto the studs.
3. Install the nuts on the four studs, and torque to 5.4 Nm (48 in. lbs.).
4. Connect the fuel line and clamp.
5. Using a pliers, reassemble the balljoint on the carburetor.
6. Connect the breather tube.
7. Connect the fuel-shutoff solenoid.

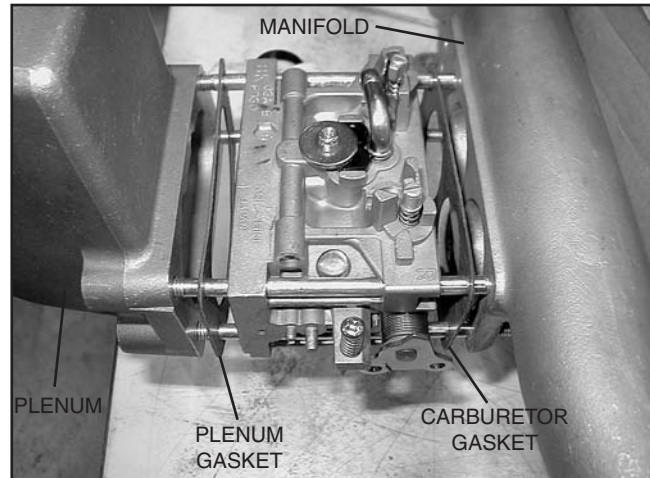


Figure 3-6.

8. Reinstall choke link on carburetor and clip the link into the bellcrank.
9. Perform a static governor adjustment. (See "Static Governor Adjustment", page 4-2)
10. Start engine and allow to warm up for 5 minutes.
11. Move speed control lever to slow speed position and hold throttle lever against idle stop screw.
12. Adjust stop screw to maintain ~1800 RPM idle.
13. Slowly move speed control lever to high speed position.

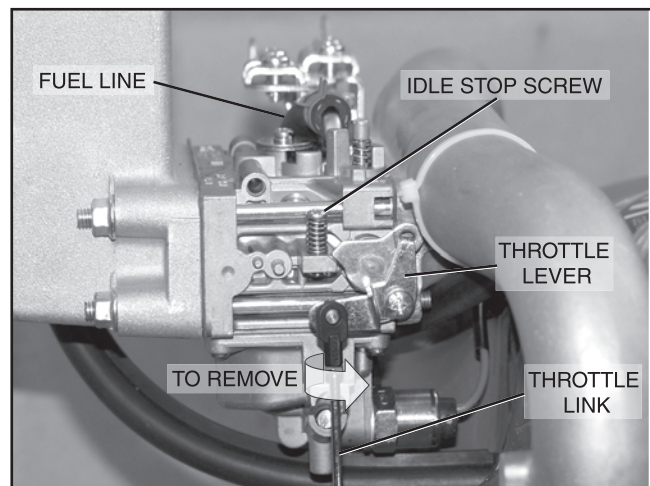


Figure 3-7.

**Note: The high speed screw may need adjusting to reach the speed control stop without exceeding 4000 RPM.**

14. With the speed control in the high speed position, adjust the high speed screw to obtain the desired engine speed. Do not exceed 4000 RPM.

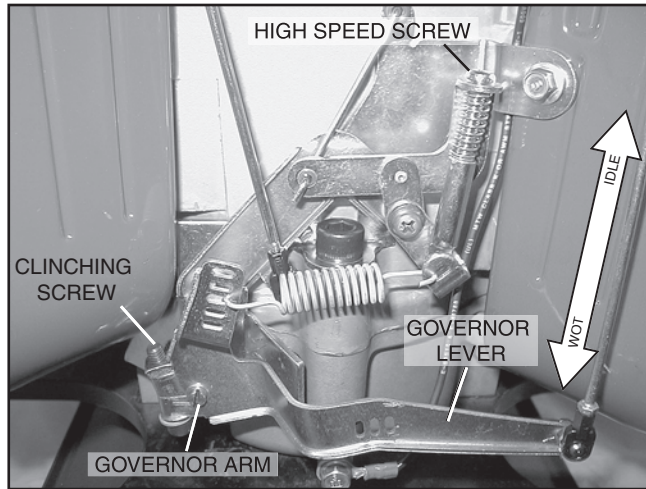
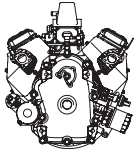


Figure 3.8.

**CARBURETOR INSTALLATION – HORIZONTAL SHAFT**

1. Install a new carburetor gasket and carburetor onto the studs.
2. Install air cleaner base, bolt and nuts and torque to 5.4 Nm (48 in. lbs.).
3. Re-attach choke and throttle links and solenoid wire to carburetor.
4. Install fuel line and fuel line clamp.
5. Install oil fill tube and hold down bolt and torque to 4.7 Nm (40 in. lbs.).
6. Install air cleaner and air cleaner cover.
7. Thread on yellow knob for Summer/Winter control.
8. Perform a static governor adjustment. **(See “Static Governor Adjustment”, page 4-2)**
9. Start engine and allow to warm up for 5 minutes.

10. Move speed control lever to slow speed position and hold throttle lever against idle stop screw.
11. Adjust stop screw to maintain ~ 1800 RPM idle.
12. Slowly move speed control lever to high-speed position.
13. With the speed control in the high speed position, adjust the high speed screw to obtain the desired engine speed. Do not exceed 4000 RPM.

**FUEL PUMP**

The fuel pump supplied with the engines is a pulse type pump. It uses crankcase vacuum pulses drawn from the valve cover to pump the fuel. It is capable of priming at 12" (30.5 cm) maximum lift, and has a maximum outlet pressure of 1.5 psi. If the fuel pump is not working properly, check the vent hole on the top of the pump for obstructions.

If a fuel pump other than the factory recommended pump is used, the fuel line pressure at the carburetor inlet must not exceed 3 psi. Pressures in excess of 3 psi may cause an over rich carburetor mixture that would lead to engine damage.

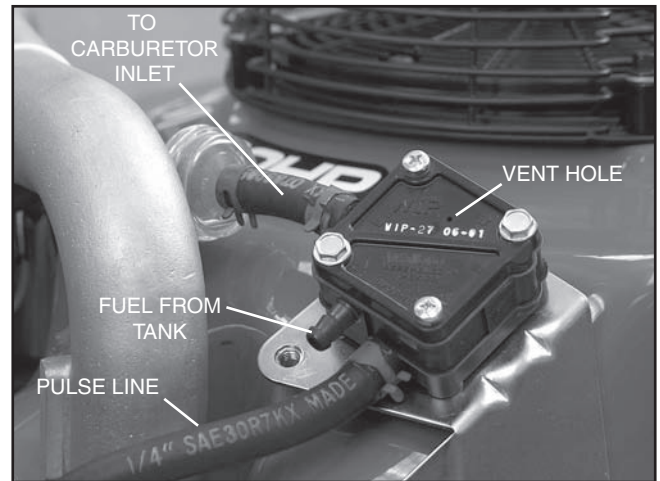
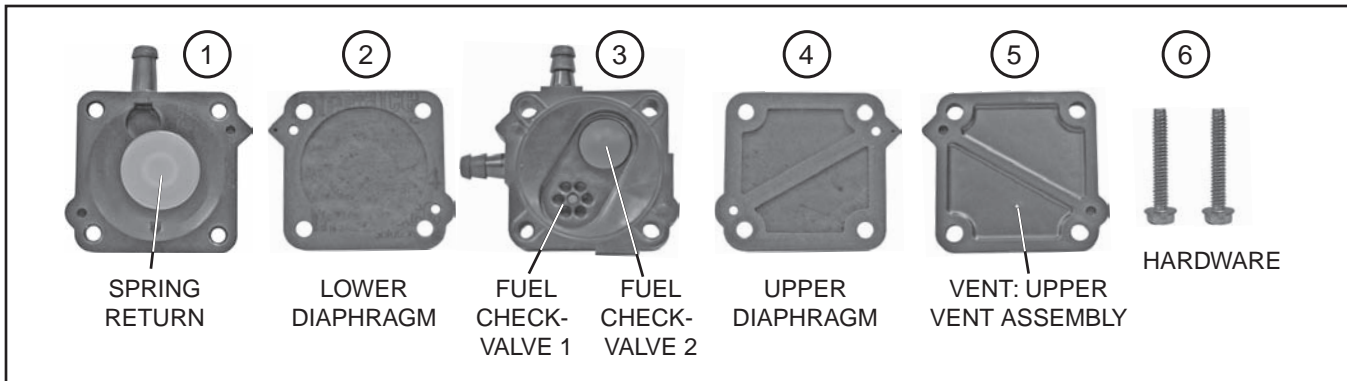
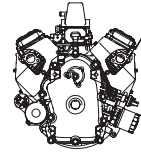


Figure 3-9. Fuel Pump



**Figure 3-10. Fuel Pump Assembly**

The pump consists of (see Figure 3-10):

1. Lower Spring assembly
2. Lower Diaphragm
3. Check Valve Assembly
4. Upper Diagram
5. Upper vent Assembly
6. Mounting Hardware x 2

As a vacuum is built up in the crankcase the Lower Diaphragm will be pulled down against the Spring Return. When the Lower Diaphragm is pulled inward fuel will flow through Check-Valve 2. As pressure is built in the crankcase the Spring Return will push the Lower diaphragm up. When the Lower diaphragm is pushed up fuel will flow through Check-Valve 1 and out the fuel port.

### LP (LIQUID) - FUEL SYSTEM

**⚠ Proper service and repair is important to the safe and reliable operation of all gaseous fueled engines. Any servicing or testing of a gaseous fueled engine must only be performed by qualified personnel. Always follow applicable installation and service procedures. An example of these requirements is found in NFPA-52 for natural gas. These are US Federal standards. Worldwide standards vary. Local, city, and state requirements may also have certain requirements that must be observed.**

LP (Liquefied Petroleum Gas) is a gaseous fuel and when stored under pressure, becomes a liquid. Although a vapor forms at the top of the tank, this particular system uses a liquid withdrawal method, drawing from the bottom of the tank.

This is accomplished with a special valve that is installed on a normal propane cylinder with a tube that is attached to the valve and extends to the bottom of the storage tank. Because of pressure in the tank, liquid propane is forced through the tube when the valve is opened.

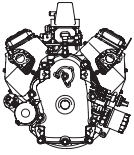
The Generac LP system starts with a pressure relief valve to prevent excessive pressure from building in the system during shutdown. This is followed by a 12 volt (normally closed) electric solenoid, which prevents the flow of fuel when the ignition key is off. When the ignition key is turned on, the solenoid opens and allows liquid LP to flow to the regulator.

The liquid fuel vaporizer regulator converts liquid propane to a vapor. The vaporizer uses spent engine cooling to provide heat to aid in the evaporation process. The regulator controls the vapor supply to an amount required by the engine. The engine's intake vacuum draws LP into the carburetor on an on-demand need. When the engine is off, the LP no longer flows from the regulator to the engine (see Figure 3-32).

### TROUBLE SHOOTING

**⚠ CAUTION! Gaseous fuels are highly explosive; do not use flame or heat to test the fuel system for leaks. LP gas is heavier than air and tends to settle in low areas; even the slightest spark can ignite these gases and cause an explosion.**

***Note: Don't assume that the fuel system is the problem. Verify that the engine has spark and enough compression to start the engine before proceeding with the following steps.***



**TESTING THE FUEL SHUT-OFF SOLENOID**

1. Remove the spark plug wires from each spark plug to prevent accidental starting of the engine.
2. Check for 12 volts DC at the solenoid terminal. See Figure 3-11.
  - a. Place one hand on the fuel solenoid and turn the ignition switch to the run position. You should be able to feel the solenoid actuate as well as hear an audible click. Replace the solenoid if it does not actuate.
3. If the solenoid is opening properly, proceed to "TESTING AND REPAIRING LPG VAPORIZER/REGULATOR".
4. Reconnect the spark plug leads when finished



Figure 3-11. LPG Solenoid Valve

**DISASSEMBLY AND ASSEMBLY OF LPG SOLENOID VALVE**

If the solenoid valve is removed for cleaning or replacing the filter, it is recommended that the special synthetic sealing gaskets be replaced. When installing new sealing gaskets, they should be lubricated using an O-ring lubricant. **DO NOT RE-USE O-RINGS!**

For improving the functional features and lifetime of the solenoid, it is recommended that the gaskets and filter be replaced after about two years of operation.

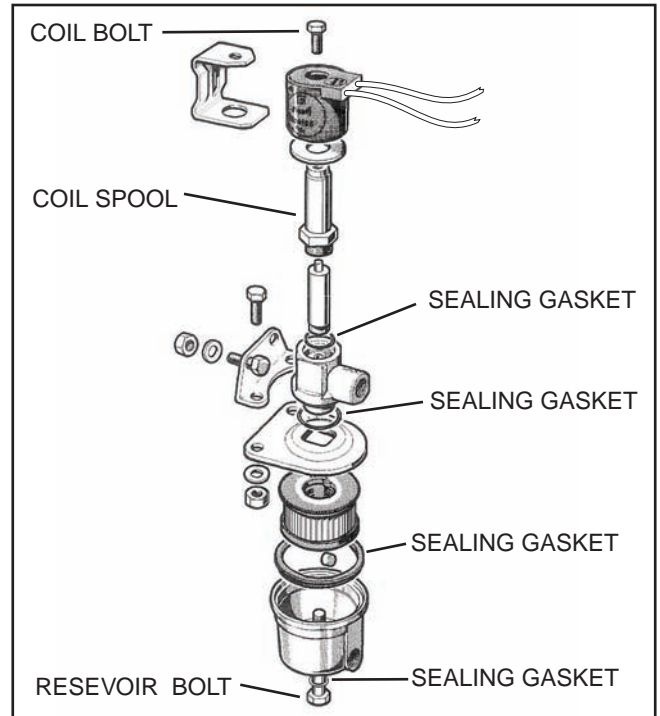


Figure 3-12. LPG Solenoid Valve Torque and Lubrication Points

**NOTE:** For correct solenoid valve fitting, it is essential that the following torque values be observed:

1	Coil Bolt	7.85 Nm (70 in. lbs.)
2	Reservoir Bolt	11.8 Nm (104 in. lbs.)
3	Coil Spool:	16.6 Nm (147 in. lbs.)

**TESTING AND REPAIRING LPG VAPORIZER/REGULATOR**

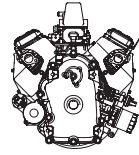
SPECIAL EQUIPMENT REQUIRED:

1. Air pressure at 100 psi, and air pressure gauge 0-15 psi, with connecting hose and fittings to attach to the 1/8" NPT female pipe connection.
2. Liquid leak detector to check for leaks (recommended).

REPAIR KIT CONTENTS:

(Refer to Parts Manual for specific part numbers.)

- Pin, Pivot, Secondary Reg Lever
- Lever, Assembly Reg Secondary
- Diaphragm, secondary
- Assembly, Diaphragm, primary
- Assembly, Lever, Primary
- Pin, Pivot, Primary



**NOTE: TEST REGULATOR ON ENGINE FIRST OR, FOR SCHEDULED MAINTENANCE, PROCEED TO "REMOVE REGULATOR AND DISMANTLE AS FOLLOWS".**

1. Make sure the fuel tank(s) have an adequate supply of fuel.
2. Make sure the valve on the tank is fully open (turned counterclockwise).

**Note: This fuel system is under high pressure.**

3. While the fuel is off, install the primary pressure test gauge at the 1/8" primary test port opening at the side of the regulator, marked "PRI". See Figure 3-14.
4. Disconnect the vapor hose at the Carburetor or Carburetor Adapter.
5. Turn on the ignition to open the fuel solenoid valve.
6. If the engine is equipped with an engine controlled safety switch, bump the starter to make contact and open the fuel solenoid valve.
7. Primary pressure should be 0.5 to 4.5 psi and hold pressure.
8. If primary pressure is too high or too low and leakage is observed at the vapor hose, the regulator must be removed, disassembled, cleaned and new parts installed.

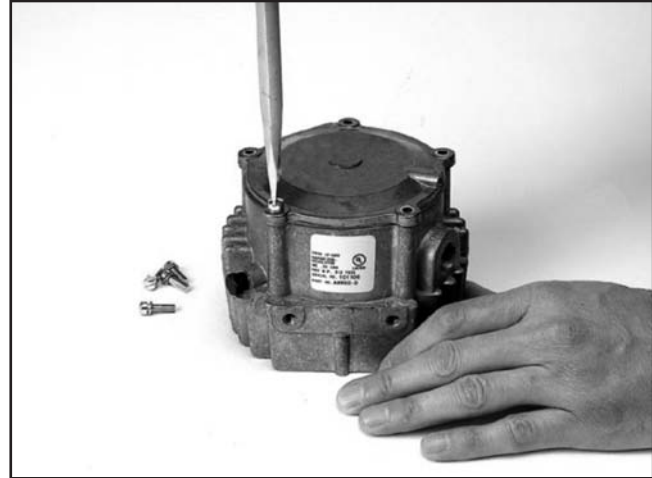
REMOVE REGULATOR AND DISASSEMBLE AS FOLLOWS:

**⚠ Caution! Prior to the removal of any LP system components, disconnect the battery and turn off the fuel supply at the tank(s).**

1. Remove the five secondary cover screws, 10-32 x 0.630", and lift the cover off the regulator body and secondary diaphragm (see Figure 3-13). The cover has a tendency to stick to the diaphragm and gasket. A slight tap on the edge of the cover with a screwdriver handle or a soft face hammer will loosen the cover.

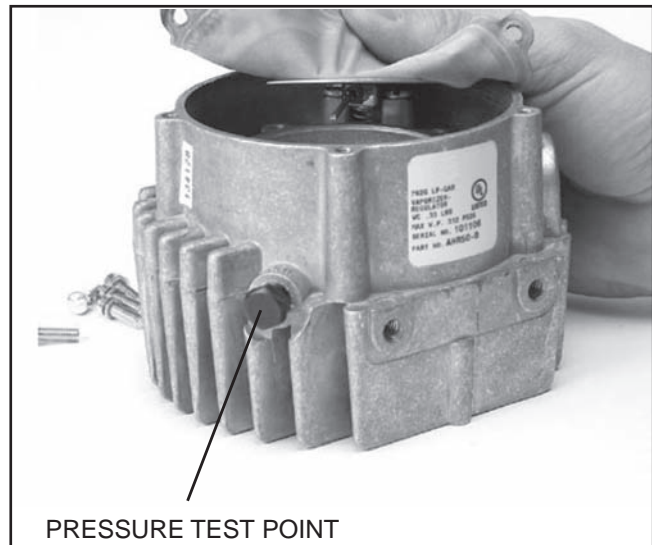
**Note: Do not pry in between the cover and the body. Damage to the sealing surface may result.**

2. After the cover has been removed, lift up an edge of the diaphragm. Observe how it is attached to the secondary lever. See Figure 3-14.
3. Remove the two screws, 10-32 x 0.310", holding the secondary lever pivot pin and remove the secondary lever and spring. The secondary pivot pin is 1.20" long. See Figure 3-15.



**Figure 3-13. Remove Five Secondary Cover Screws**

4. Remove the four screws, 10-32 x 0.630", holding the primary diaphragm cover in place. If the cover sticks, use a screwdriver handle or soft-faced hammer to dislodge it. Observe that the longer (2), 10-32 x 1.0", of the six screws are at the top of the cover. Remove primary spring. See Figure 3-16.



**Figure 3-14. Lift Edge of Diaphragm**

5. Remove the primary diaphragm. See Figure 3-17.
6. Remove the two screws, 8-32 x 0.375" long. See Figure 3-18.

**Note: Remove oil and foreign deposits from all chambers and parts. DO NOT APPLY LIQUID CLEANERS TO THE DIAPHRAGMS AND NEOPRENE FACED VALVES.**

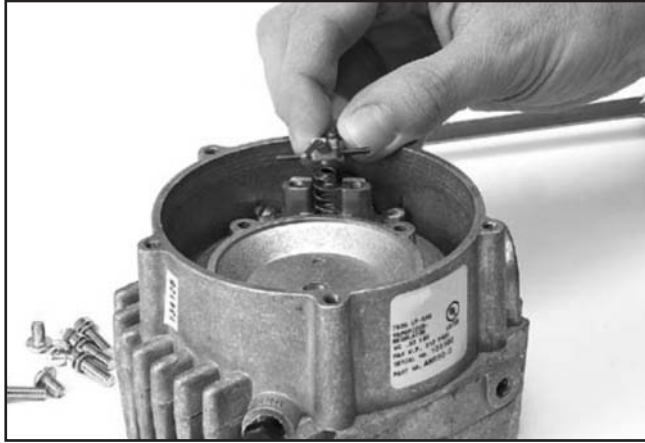
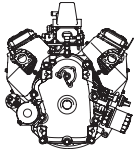


Figure 3-15. Remove Secondary Lever and Spring

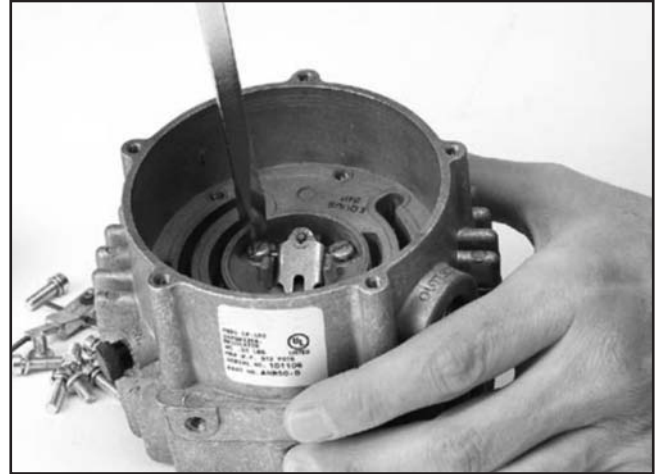


Figure 3-18. Remove/Replace Two Screws 8-32 x 0.375" long



Figure 3-16. Remove Primary Diaphragm Cover and Primary Spring

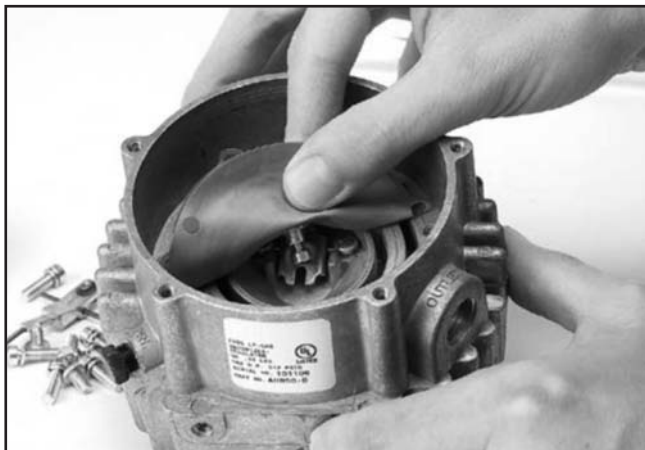


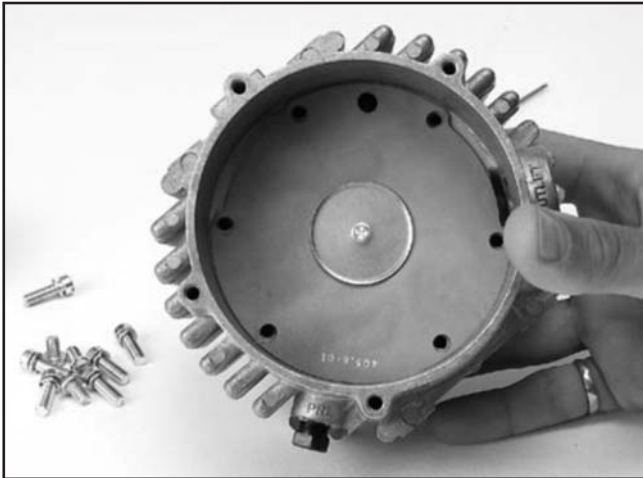
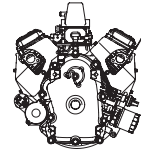
Figure 3-17. Remove Primary Diaphragm

REASSEMBLY OF REGULATOR:

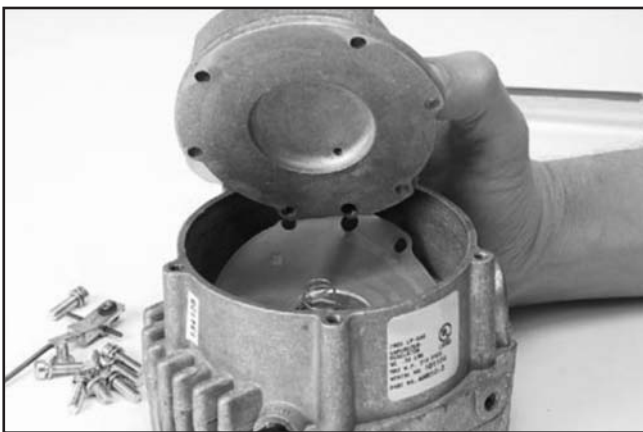
1. Carefully clean and inspect all metal parts—springs, levers, pivot pins and screws. Replace all parts that are included in the repair and rebuilding kits.
2. Carefully clean the body casting and inspect all sealing surfaces. Wipe with a clean rag. Inspect the primary section for foreign materials that might loosen and damage the soft face valves.
3. Blow out the fuel inlet passage and outlet passages. Be sure no foreign material remains in these passages.
4. Inspect the primary orifice and the secondary orifice for nicks scratches or uneven wear.

**IMPORTANT! If the primary or secondary seats show any of the above mentioned conditions, the regulator is not rebuildable and must be replaced.**

5. Lay the regulator flat on a clean working surface with the primary section up.
6. Replace the primary pivot pin, 0.890", bridge and two screws, 8-32 x 0.375". Tighten screws evenly to 30 in. lbs.  $\pm 3$  in. lbs. (3.39 Nm  $\pm$  0.339 Nm). Rock the primary lever assembly to ensure that it pivots freely. See Figure 3-18.
7. Engage the primary diaphragm pin with the slot in the primary lever. Rotate the diaphragm to align the cover screw holes as shown in Figure 3-19.
8. Place primary spring, small side up, on top of diaphragm. Install primary cover and screws. Remember, the 2 longer, 10-32 x 1.0", screws go to the top of the primary cover. Tighten evenly, in a criss-cross pattern, to 30 in. lbs.  $\pm 3$  in. lbs. (3.39 Nm  $\pm$  0.339 Nm). See Figure 3-20.



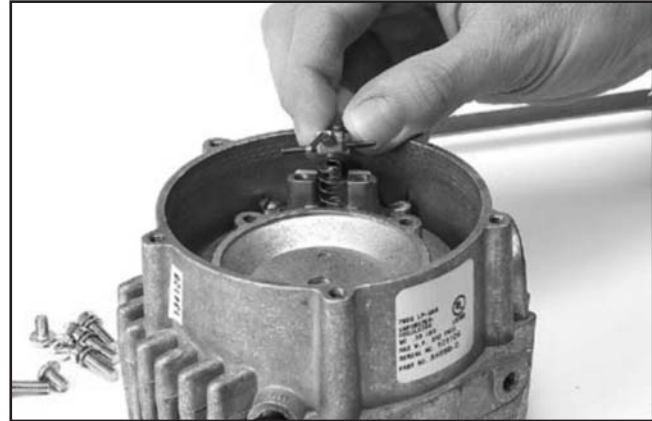
**Figure 3-19. Rotate The Diaphragm To Align the Cover Screw Holes**



**Figure 3-20. Install Primary Spring, Primary Cover and Screws**

9. Place secondary valve spring (5/16" dia. x 5/8" long) in spring recess near secondary orifice. Replace secondary lever, pivot pin, 1.19" long, and two screws, 10-32 x 0.310". Make sure the spring fits over the spring boss on the secondary lever. Tighten screws evenly to 30 in. lbs.  $\pm 3$  in. lbs. (3.39 Nm  $\pm$  0.339 Nm). See Figure 3-22.
10. The secondary lever (except for the bent tail tip) should be level or flush with the top of casting. Bend tail end of lever if necessary but do not use excessive force on the rubber valve against the orifice. See Figure 3-22.
11. The secondary lever has a soft valve surface on an aluminum insert which must be swiveled into flat contact with the orifice. Place a pointed instrument in the top indentation of the valve. Apply slight downward pressure and with a gentle rotary motion, swivel the valve into flat contact with the orifice. These valve inserts are not sold separately

but are crimped at the factory with proper tension to allow movement but still hold their position. See Figure 3-23.



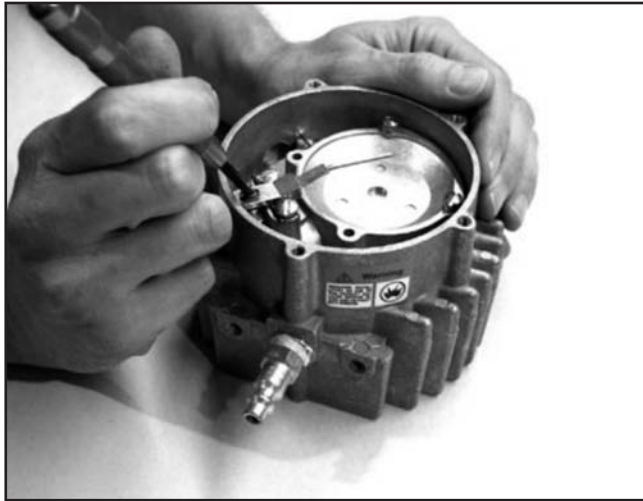
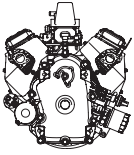
**Figure 3-21. Install Secondary Valve Spring, Lever and Pivot Pin**



**Figure 3-22. Make Sure Secondary Lever is Flush With Top of Casting**

12. Attach primary pressure gauge at the primary pressure test port opening. See Figure 3-24.
13. Attach air pressure hose to the regulator fuel inlet with approximately 100 psi,  $\pm 10$  psi air pressure. See Figure 3-25.
14. Slowly depress the secondary lever bent tail end until you are able to detect flow out of the secondary orifice. Let the lever then slowly return to the closed position. Observe the primary pressure reading on the installed gauge. It should be between 0.8 and 2.5 psi. If it is not, recheck your work in the primary fuel section. See Figure 3-26.

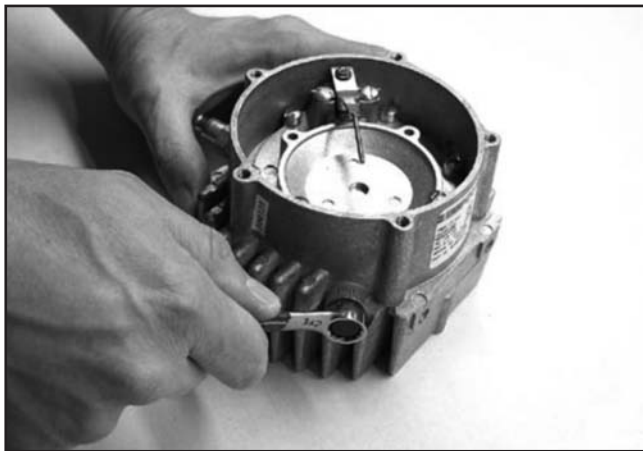




**Figure 3-23. Positioning Secondary Lever Valve**

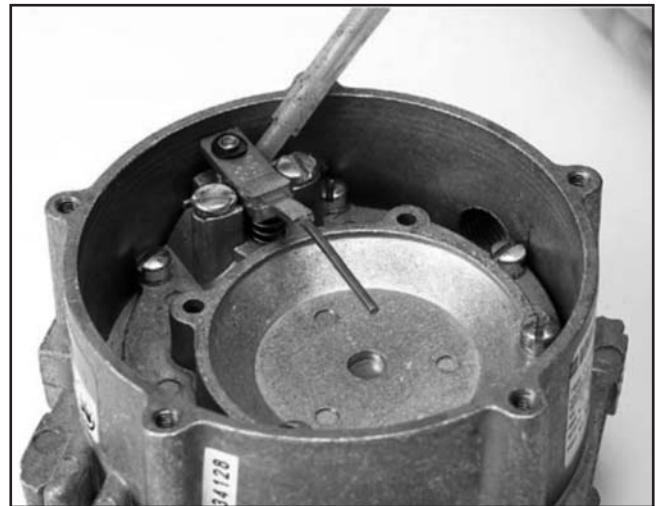


**Figure 3-26. Check Primary Pressure Reading**

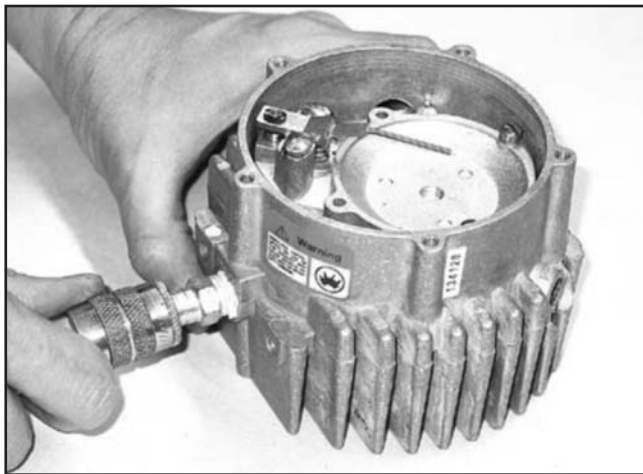


**Figure 3-24. Primary Pressure Test Port Opening**

15. Check around the secondary seat for leaks using a liquid leak detector solution. If a leak is detected, repeat Step 11 to insure no leakage at the secondary seat. See Figure 3-27.

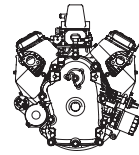


**Figure 3-27. Check Secondary Seat for Leaks**



**Figure 3-25. Attach Air Pressure Hose**

16. Turn off the air supply. Install the secondary diaphragm by hooking the secondary lever through the center pin. If the screw hole tabs do not line up with the casting, remove and rotate the diaphragm 180 degrees and reinstall. See Figure 3-28.
17. Install secondary cover and align the cover and diaphragm notches. Carefully start all five screws, 20-32 x 0.630", through cover and diaphragm holes. Tighten evenly, in a criss-cross pattern, to 30 in. lbs.  $\pm 3$  in. lbs. (3.39 Nm  $\pm$  0.339 Nm). See Figure 3-29.



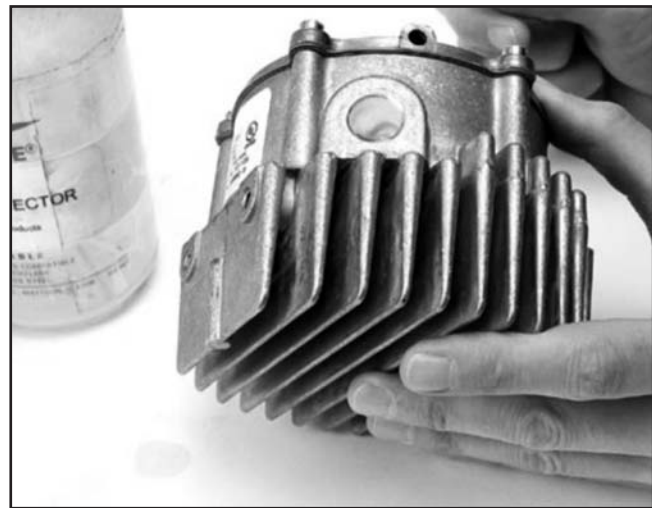
**Figure 3-28. Install Secondary Diaphragm**



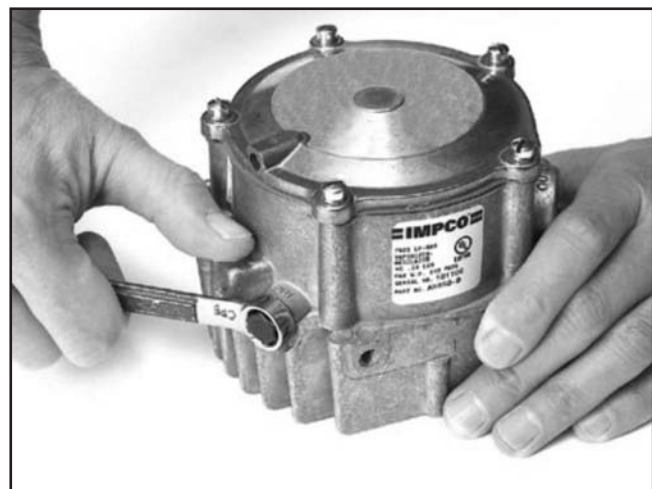
**Figure 3-29. Install Secondary Cover**

18. Draw a bubble of leak detector over the "OUTLET" port. The bubble should hold for several seconds with the regulator inlet pressurized. Return to step 10 if the bubble doesn't hold for several seconds. See Figure 3-30.
19. Remove air pressure supply and primary pressure test gauge. Replace the 1/8" pipe plug in the primary pressure test opening. See Figure 3-31.
20. Install the regulator.
  - a. Clean all threaded areas and use a commercially available pipe sealant. Make sure sealant does not get inside of the regulator.

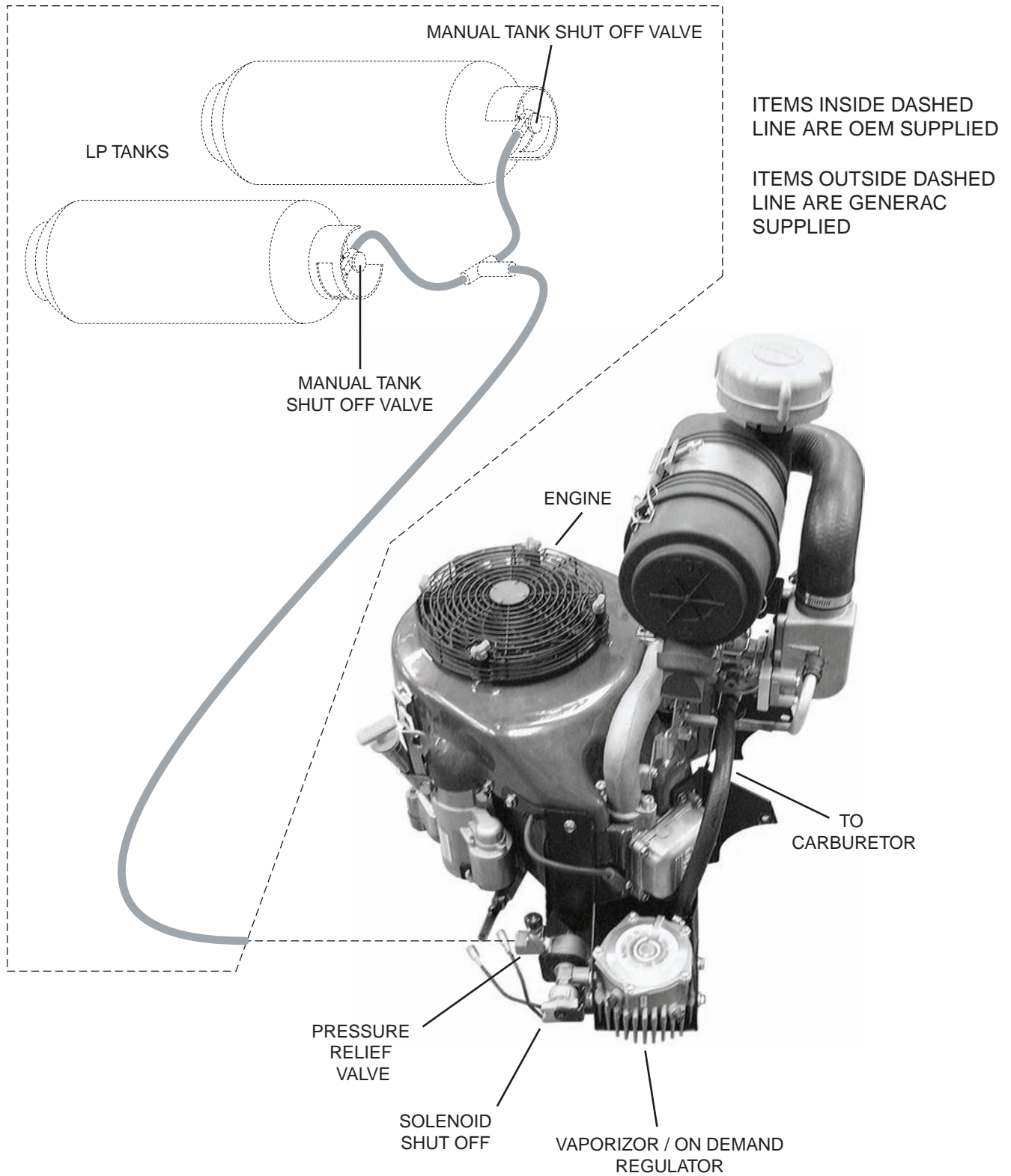
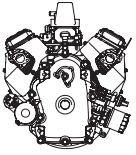
- b. Connect LP line(s), reconnect battery and turn on fuel supply at the tank(s).
  - c. Turn ignition switch to the "ON" position to verify that the solenoid is opening.
  - d. Check all fuel connections with a leak detector. If leaks are present, go back to Step 20a.
  - e. Run the engine until it is at full operating temperature.
21. Repair is now complete.



**Figure 3-30. Check Outlet Port**



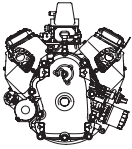
**Figure 3-31. Re-install Pipe Plug in Test Opening**



NOTE: ALL FUEL LINES ARE REQUIRED TO BE BRAIDED STAINLESS STEEL COVERED.

Figure 3-32. Typical LP (Liquid) System





### MECHANICAL GOVERNOR

#### DISASSEMBLE:

1. Drain the oil from the engine.
2. Remove any rust, nicks, or burrs from the crankshaft.
3. Remove the four (4) oil cooler screws.
4. Disconnect the wiring from the oil pressure switch.
5. Remove the governor lever from the shaft.
6. Separate the ball joint on the swinging arm.
7. Remove all of the crankcase bolts and slide the crankcase cover off.

**Note:** Watch the swinging arm bracket so that it doesn't hook on the sheet metal.

8. Discard the crankcase gasket & oil passage o-ring.

### GOVERNOR

Both the spool and the flyweights must move freely for the governor to work properly. Check for wear on the spool and flyweights. If wear is noticed, change the governor gear assembly (gear and flyweights), spool, and governor arm. Lubricate all moving parts when reassembling.

#### GOVERNOR REMOVAL AND INSTALLATION:

1. Leverage gear assembly and governor spool off of governor shaft.

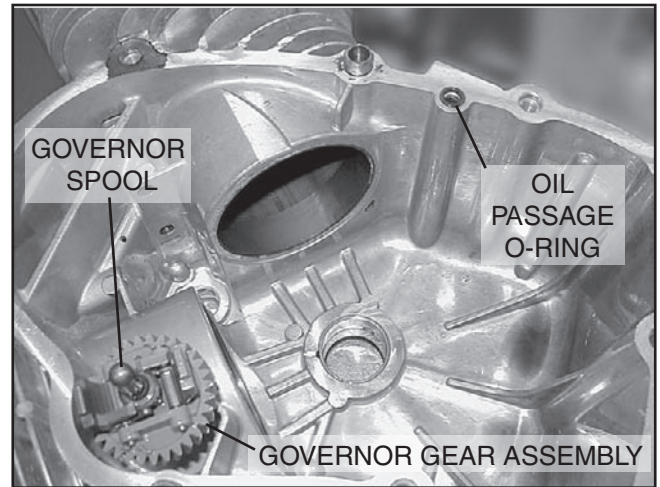


Figure 4-1. Governor Gear Assembly and Spool

2. Remove any remaining plastic from the notch in the governor shaft.
3. Check that all the governor bearing parts (top plate, bearing, and bottom plate) are on the shaft, and that it moves smoothly.
4. Slide the new gear assembly and spool onto the governor shaft. Slide until the gear hooks into the notch in the governor shaft.

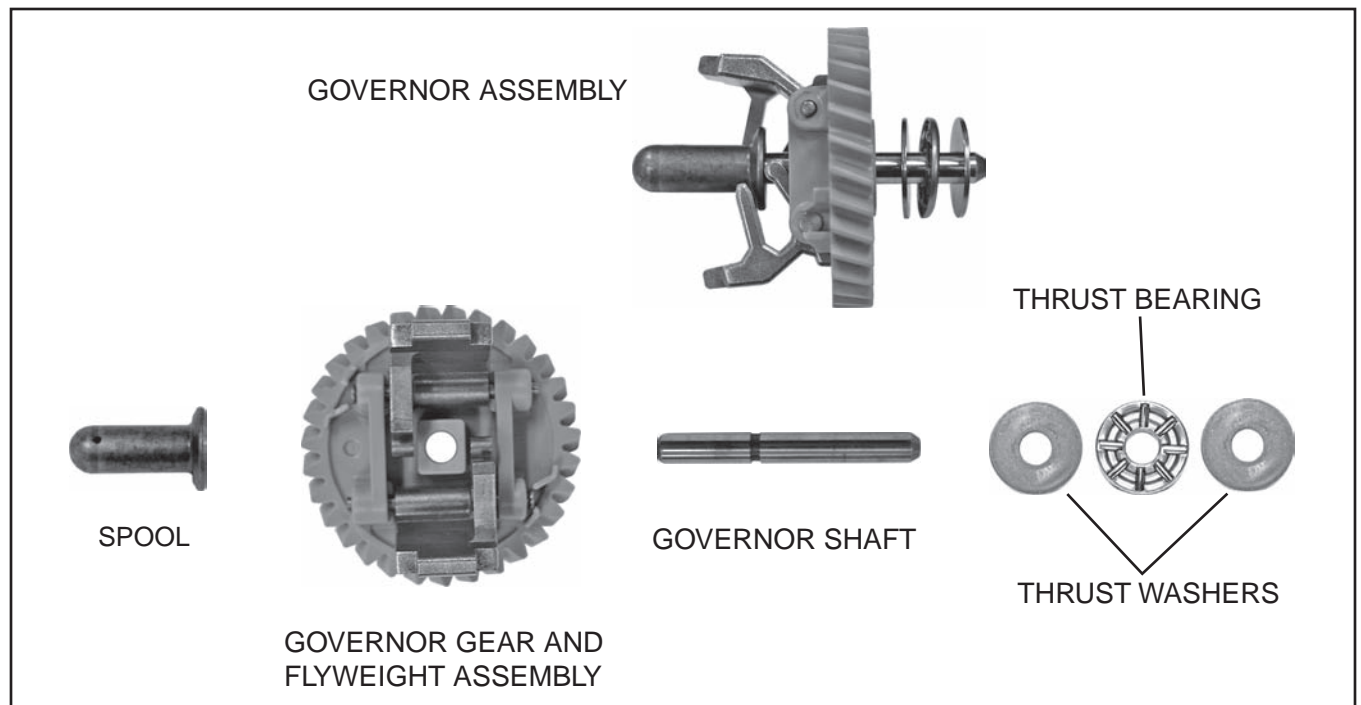
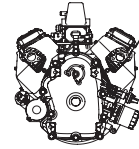


Figure 4-2. Governor Assembly and Components



**GOVERNOR ARM**

If the governor arm does not move freely, or if the arm feels loose in the bushings, it may need replacing. If wear is noticed, change the governor arm, governor gear assembly (gear and flyweights), spool, and bushings as needed. Lubricate all moving parts when reassembling.

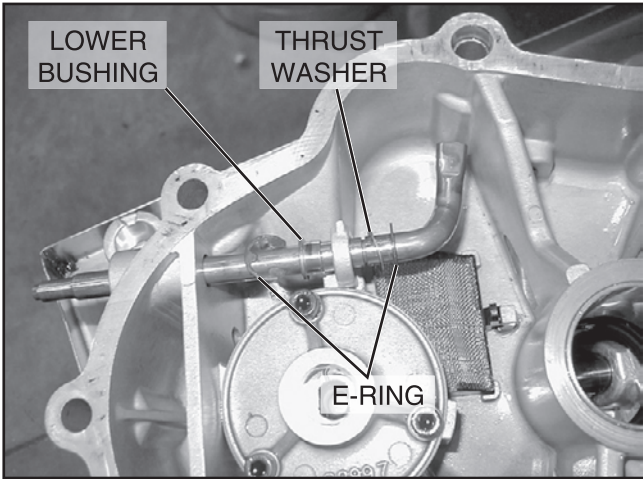


Figure 4-3. Governor Arm Assembly

1. Remove the e-clips.
2. Slide the arm down and out of the bushings.
3. Replace any parts that appear worn.

**Note: The lower bushing is a slip fit, and the upper bushing is pressed in.**

4. Slide the thrust washer part way onto the new governor arm.
5. Insert the governor arm in the lower bushing holder, and slide it part way in.
6. Install lower e-clip on the arm, and slide the thrust washer down to it.
7. Slip the lower bushing part way on to the arm.
8. Slide the arm in until the thrust washer is tight.
9. Slide the lower bushing down and into its holder, then install the upper e-clip.

ASSEMBLE:

1. Clean any old gasket material from the crankcase and cover mating surfaces.

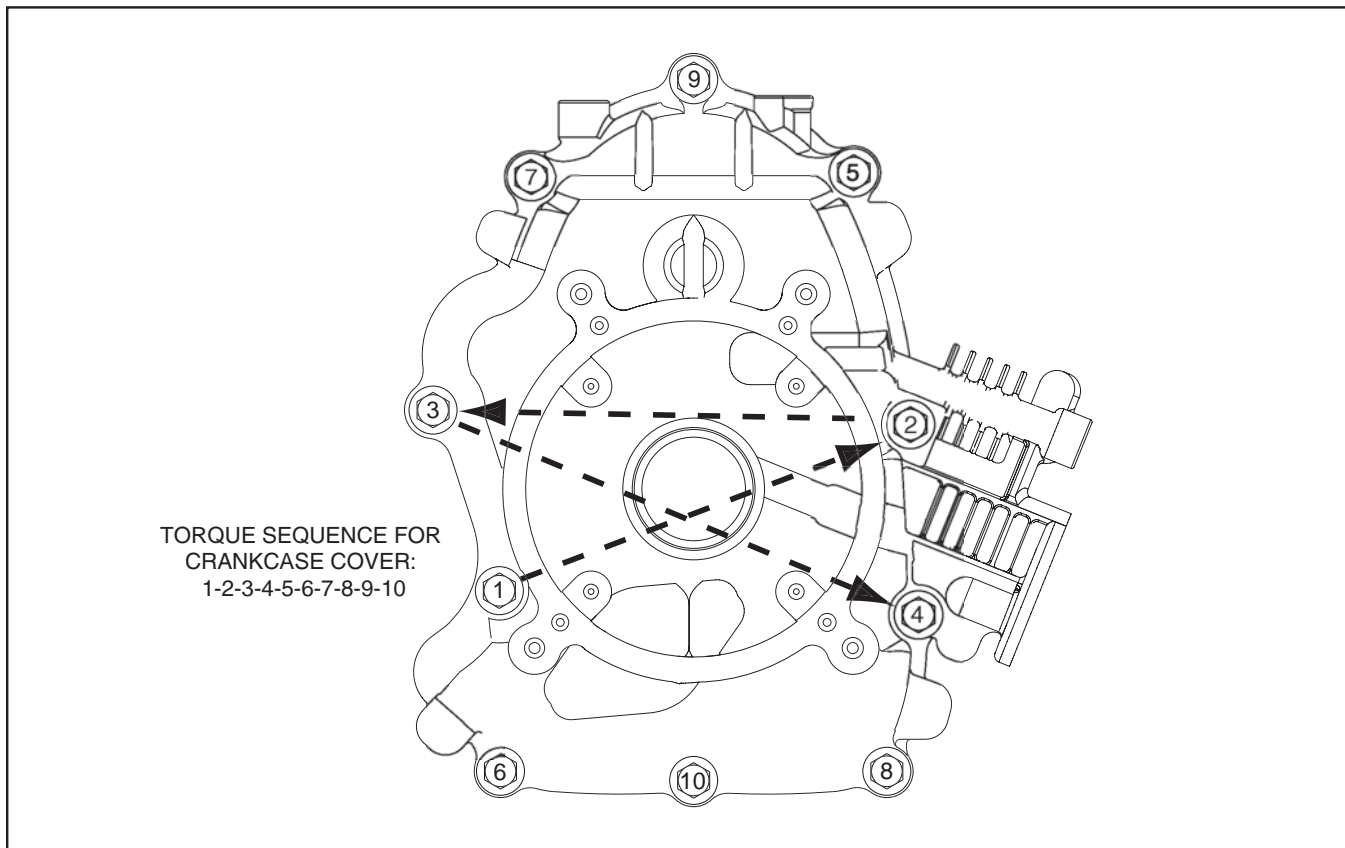
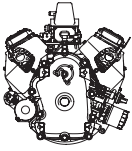


Figure 4-4. Crankcase Bolt Torque Sequence



2. Be sure that the new oil passage o-ring is in place (see Figure 4-1).
3. Put a new gasket on the crankcase.
4. Slide the crankcase cover back on the crankcase.

**Note: Hold the governor arm in the counter-clockwise position while installing. Also, make sure that the swinging arm bracket goes in place.**

5. Start all of the crankcase bolts, and then torque them to 47.5 Nm (35 ft. lbs.), following the proper torque sequence (see Figure 4-4).
6. Reconnect the ball joint on the swing arm.
7. Place the governor lever on the governor arm. Place the governor spring in the 4th hole out.
8. Perform a static governor adjustment (see below).
9. Reconnect the ground wire to the oil pressure switch.
10. Reattach the oil cooler to the blower housing.

### STATIC GOVERNOR ADJUSTMENT

Determine which version of governor linkage is installed on the engine. Refer to Figures 4-5 (earlier version) and 4-6 (later version).

1. Loosen the clinching screw on the governor lever.
2. Rotate the governor arm clockwise and hold governor lever in WOT (Wide Open Throttle) position.
3. While holding this position, torque the clinching screw to 11.3 Nm (100 in. lbs.).
4. Check to make sure that the throttle travels from WOT to IDLE. If it doesn't, the governor needs to be reset again.

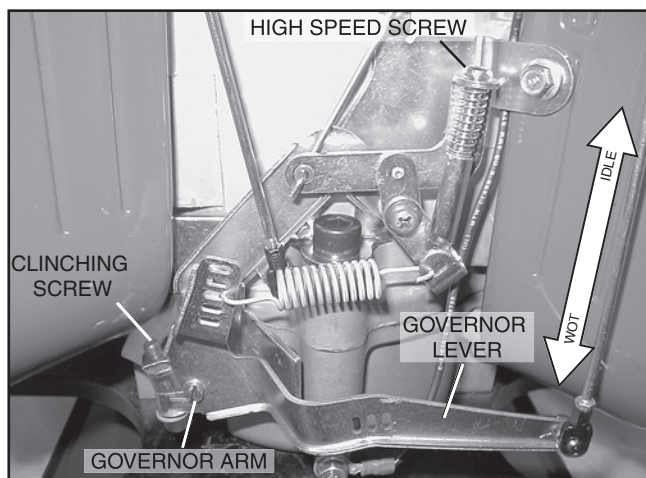


Figure 4-5. Static Governor Adjustment

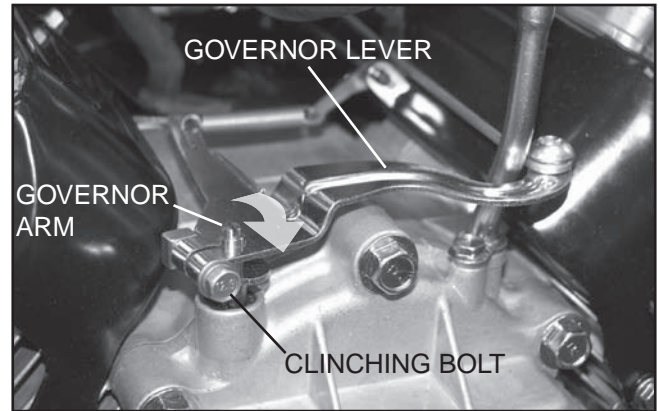


Figure 4-6. Static Governor Adjustment (Later Version)

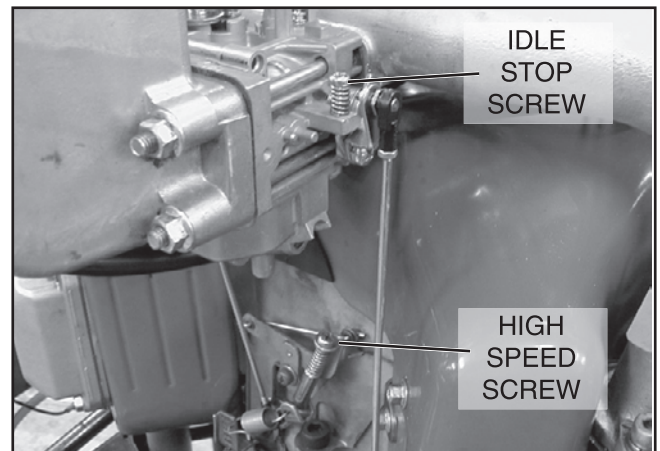


Figure 4-7. Dynamic Governor Adjustment (Earlier Version)

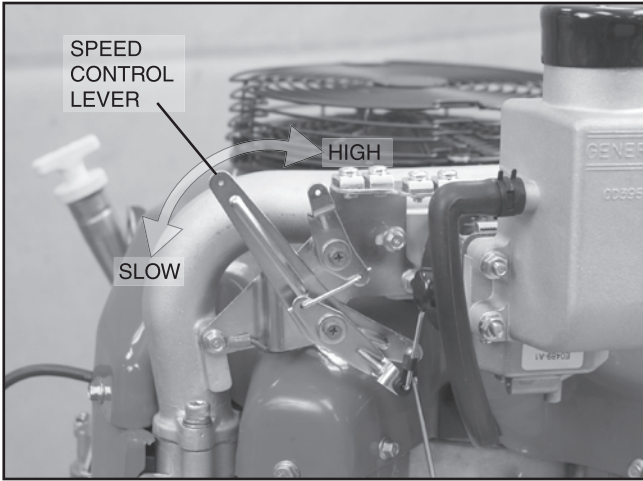
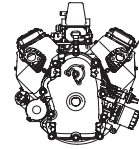
### DYNAMIC GOVERNOR ADJUSTMENT

1. Start engine and allow to warm up for 5 minutes.
2. Move speed control lever to slow speed position and hold throttle lever against idle stop screw (see Figure 4-7).
3. Adjust stop screw to maintain 1800 RPM idle.
4. Slowly move speed control lever to high-speed position. Do not exceed 4000 RPM (see Figures 4-7 or 4-10 depending on governor version).

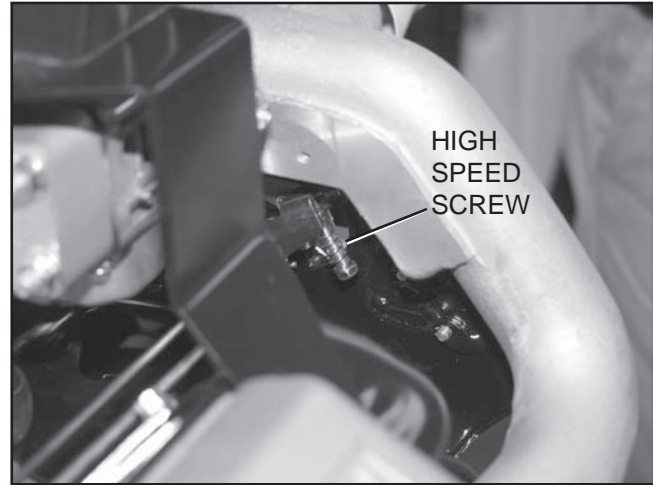
**Note: On the later governor version, insert an allen wrench or similar object into the hole in the control panel behind the speed control lever. This acts as a temporary stop during adjustment.**

**Note: The high-speed screw may need adjusting to reach the speed control stop without exceeding 4000 RPM.**

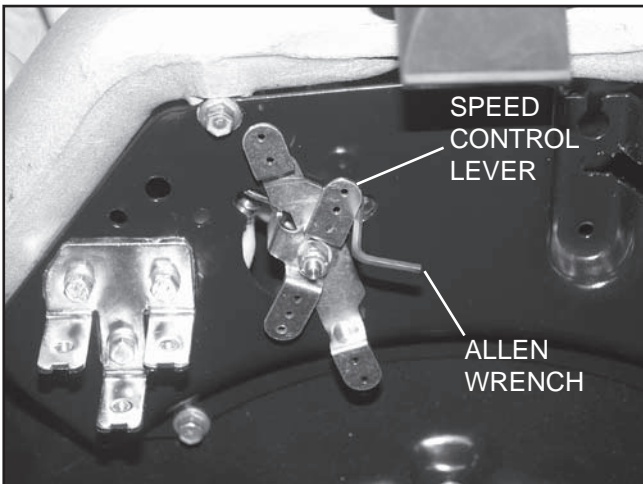
5. With the speed control in the high-speed position, adjust the high-speed screw to obtain the desired engine speed (see Figures 4-7 or 4-10 depending on governor version).



*Figure 4-8. Dynamic Governor Adjustment (Vertical Shaft)*

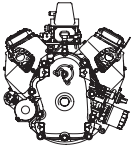


*Figure 4-10. Dynamic Governor Adjustment (Horizontal Shaft)*



*Figure 4-9. Dynamic Governor Adjustment (Horizontal Shaft)*





**GENERAL INFORMATION**

Compression testing information and procedures is described in Section 1, under "Troubleshooting".

Cylinders are numbered as shown in Figure 5-1.

**Note: Cylinder #1 is closest to the flywheel.**

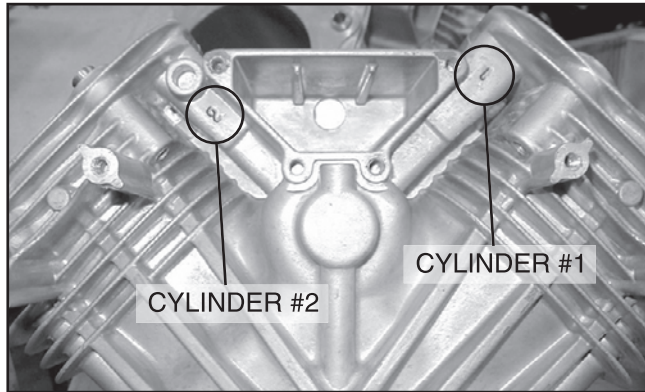


Figure 5-1.

**REMOVE CYLINDER HEADS**

Disconnect exhaust system from exhaust manifold. Remove exhaust manifold from engine. Disconnect choke and throttle control cables. Remove spark plugs.

1. Remove the parts depicted in Figure 5-2.
  - a. Discard gaskets and valve cover seals.

REMOVE ROCKER ARMS:

1. Unlock jam nuts and remove two ball studs and rocker arm assemblies (see Figure 5-3).
2. Remove push rods and identify each.

**Note: The valve push rods are aluminum. Mark push rods for identification to prevent interchanging.**

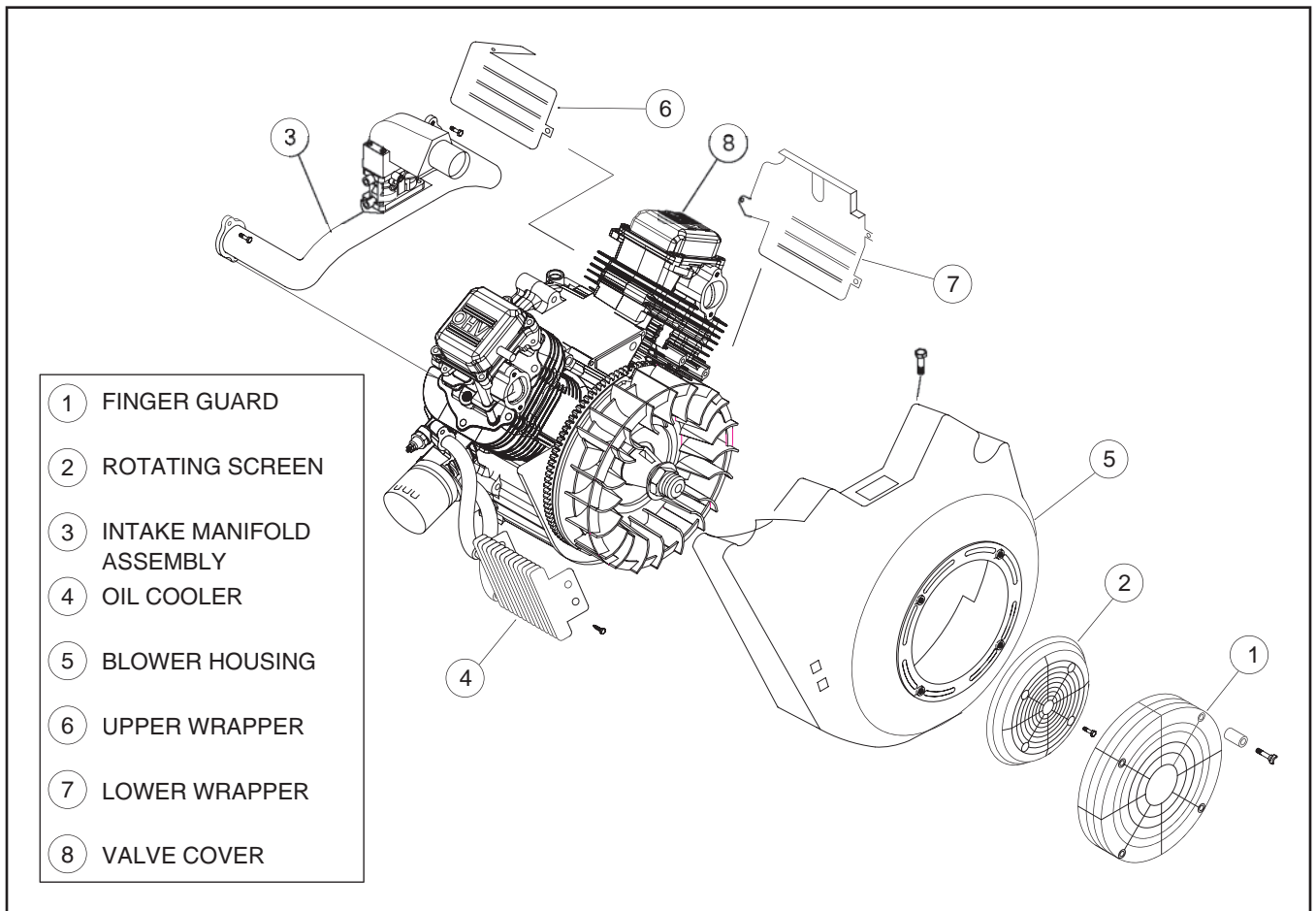


Figure 5-2.

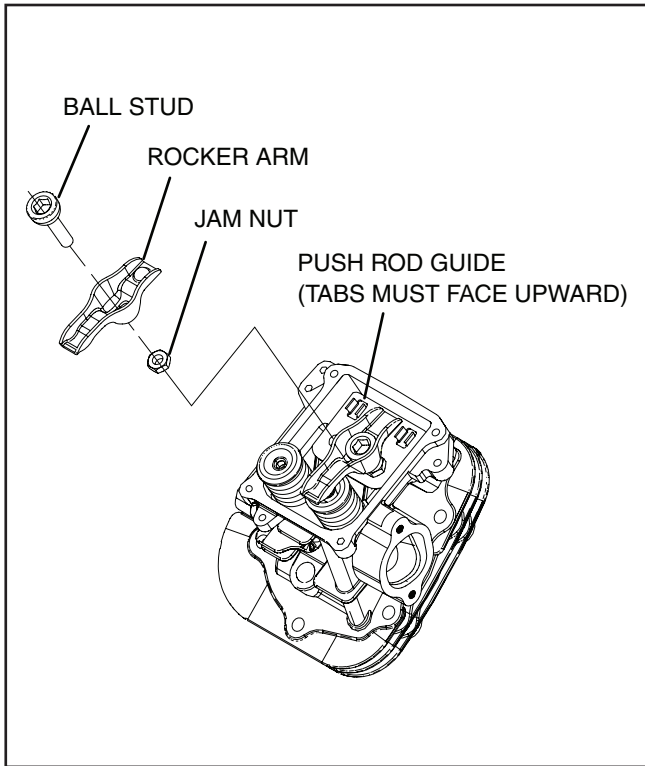
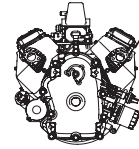


Figure 5-3.

3. Remove push rod guide plate.
4. Remove head bolts and cylinder head (Figure 5-4).
  - a. Discard gasket.
5. Repeat Steps 1-4 for other cylinder head.

**DISASSEMBLE CYLINDER HEAD**

1. Place a shop rag or short section of rubber fuel line under valves inside combustion chamber to hold valve in place while compressing spring.
2. Hold down valve spring retainer with a valve spring compressor (Figure 5-5). Remove the following:
  - a. Valve spring keepers
  - b. Valve spring retainer
  - c. Valve spring
  - d. Intake and exhaust valves
3. Remove and discard valve stem seals (Figure 5-6).

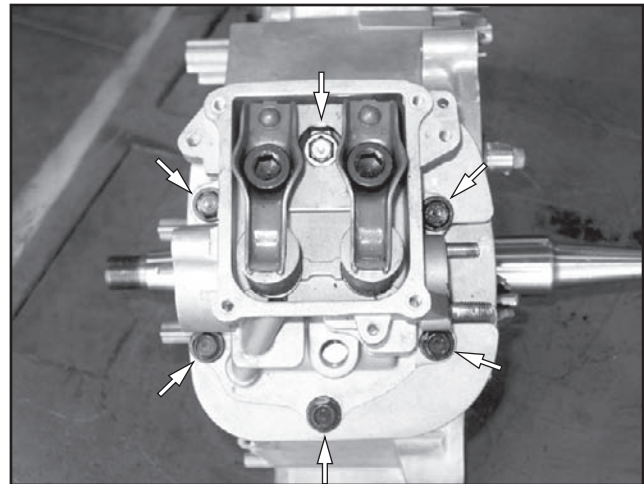


Figure 5-4. Remove Cylinder Head

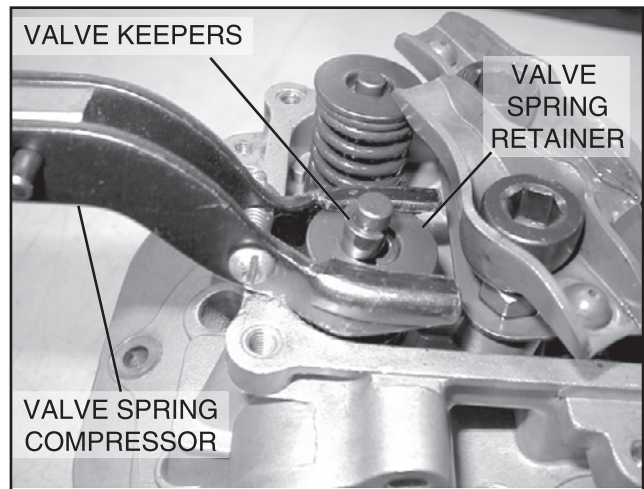


Figure 5-5. Removing Retainers

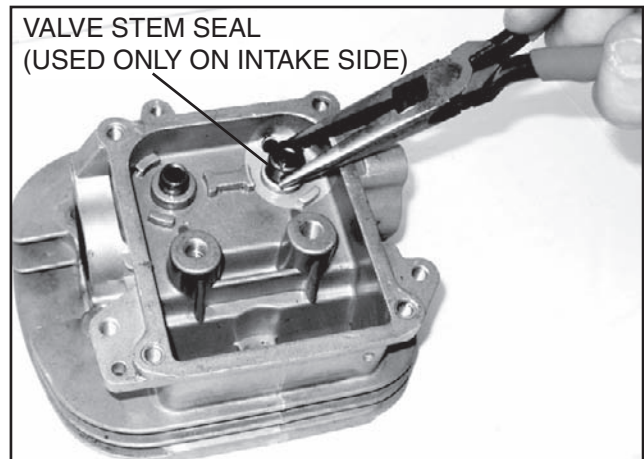
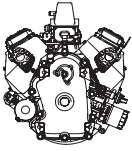


Figure 5-6. Removing Valve Stem Seals



**INSPECT AND REPAIR**

1. Check cylinder head (Figure 5-7). Be sure all gasket material is removed from surfaces before checking. Use a gasket scraper if necessary.
  - a. Inspect cylinder head for cracks or damage.
  - b. Use a surface plate or straightedge and check cylinder head mounting surface for distortion.

If mounting surfaces are distorted more than 0.1 mm (.004"), the cylinder head must be replaced.

**Note: It is not recommended that cylinder head mounting surfaces be resurfaced.**

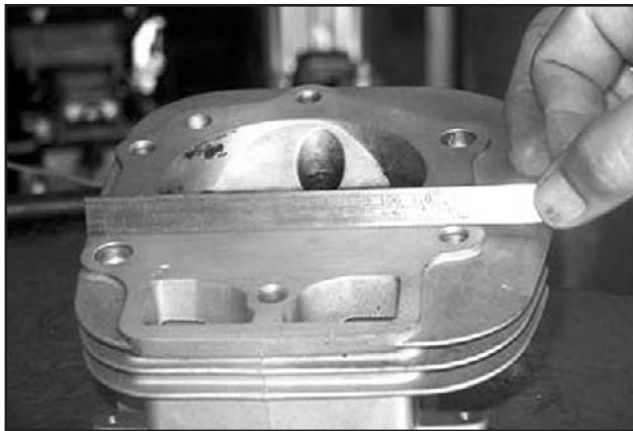


Figure 5-7. Check Cylinder Head Distortion

2. Clean the valve guides and measure their I.D. using a split ball bore gauge (Figure 5-8).
  - a. Replace head if either valve guide measures 7.06 mm (0.278 in.) or more.

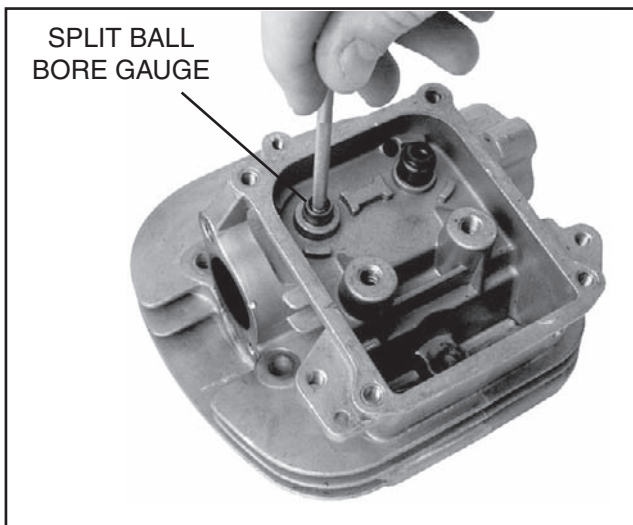


Figure 5-8. Check valve guides

REFACE VALVES AND SEATS:

1. Valve seats may be reconditioned using a valve seat cutter. If valve seat is wider than dimension shown in Figure 5-9, a narrowing cutter should be used to ensure that contact area of valve seat is centered on face of valve (see Figure 5-10).
  - a. Use a 60° cutter to narrow seat from bottom and a 15° cutter to narrow seat from top (Figure 5-9).

**Note: If valve seat is loose or cracked, replace cylinder head.**

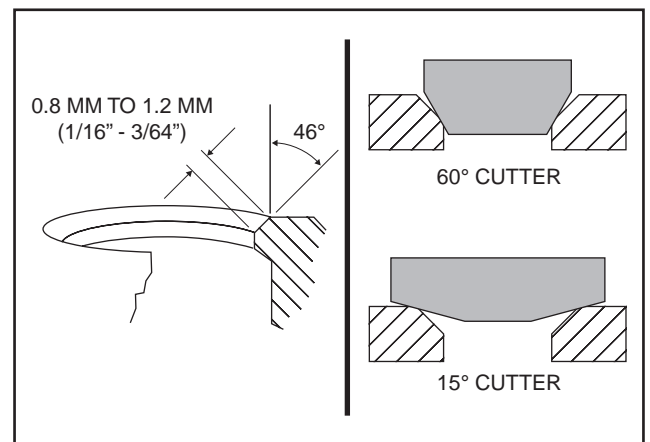


Figure 5-9. Valve Seat Dimensions

2. Valve faces may be resurfaced to 45°. See Figure 5-10 for dimensions for valves.
3. Lap valves and seats with a valve lapping tool and valve lapping compound.

**Note: Thoroughly remove all lapping compound before final assembly.**

**Note: In most instances it is more economical to replace the valves than to reface them.**

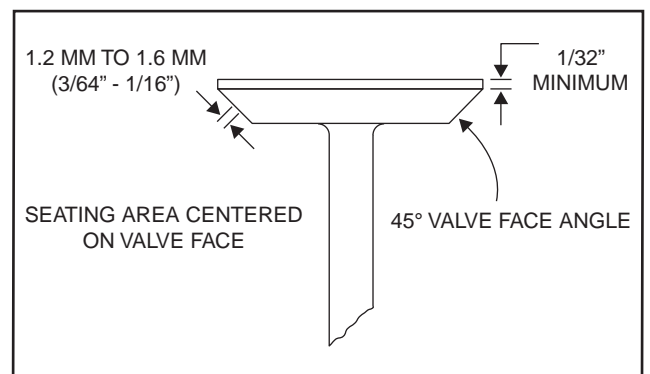
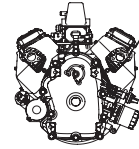
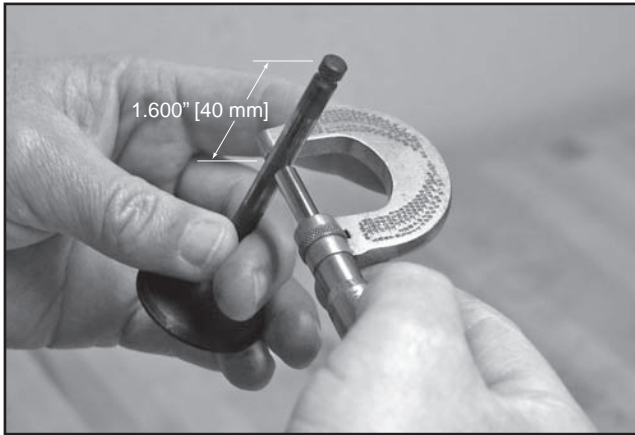


Figure 5-10. Valve Dimensions



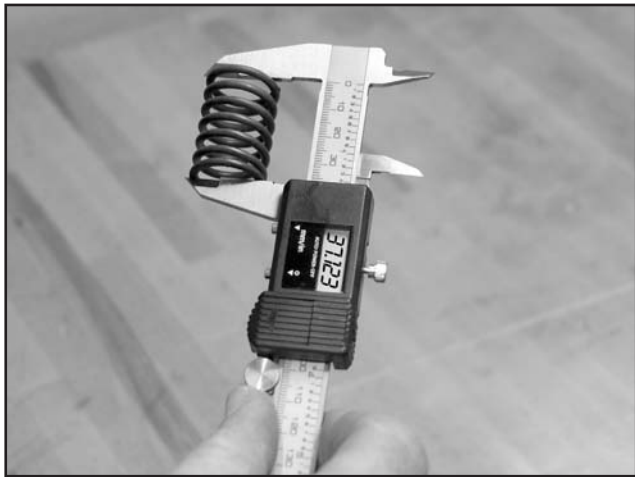
4. Measure valve stem diameter at specified distance from end of valve, as shown in Figure 5-11.

Replace if less than 6.9 mm (0.272 inches), or if total clearance between valve stem and valve guide exceeds 0.12 mm (0.0047 in).



**Figure 5-11. Measure Valve Stem Diameter**

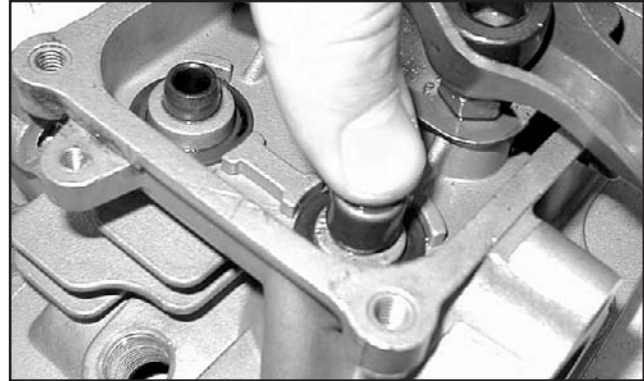
5. Check valve springs for free length (Figure 5-12).  
Replace if free length is less than 36.5 mm (1.437 inches).



**Figure 5-12. Check Valve Springs**

**ASSEMBLE CYLINDER HEAD**

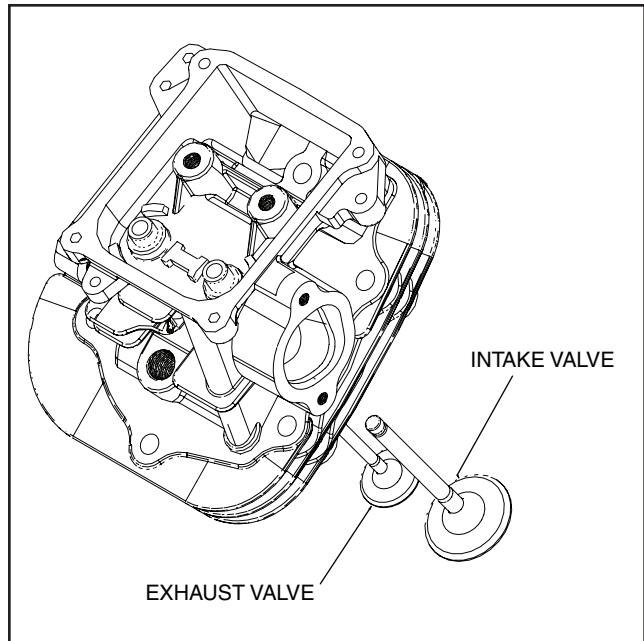
1. Install new valve stem seals.
  - a. Press seal on to intake valve guide bushing until it bottoms (Figure 5-13).
  - b. Lubricate inner top lip of valve stem seal with oil.



**Figure 5-13. Install Valve Stem Seals**

2. Install valves (Figure 5-14).

**Note:** Lightly coat valve stems with oil or Spectra Lube Red before installing valves. Be sure lubricant is not on valve face, seat or end of valve stem.



**Figure 5-14. Install Valves**

3. Place a shop rag or short section of rubber fuel line under valves inside combustion chamber to hold valve in place while compressing spring.
4. Install valve springs and valve spring retainers over valve stems.
5. Compress valve spring and install keepers (Figure 5-15).

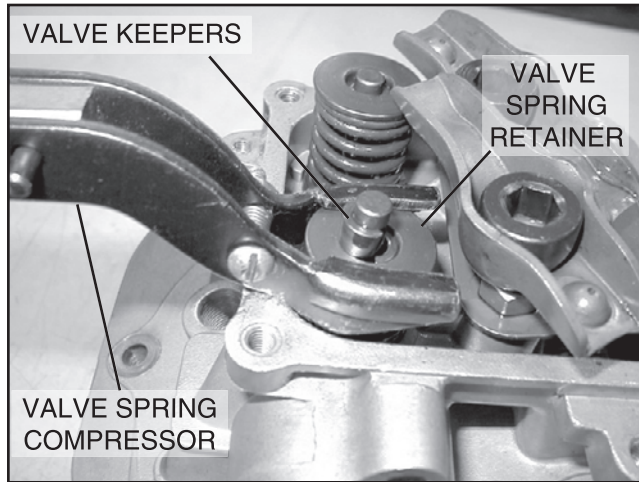
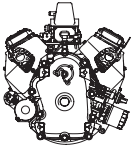


Figure 5-15. Compress valve spring and install keepers

6. Repeat procedure for other valve(s).
7. Set push rod guide plate in place with tabs facing upward, and loosely install rocker arm assemblies (ball stud, rocker arm and jam nut).
8. Repeat Step 7 for other head.

**INSTALL CYLINDER HEAD**

1. Install cylinder head with new gasket.
2. Torque head bolts in sequence shown to 29.9 Nm (22 ft. lbs.) (Figure 5-16).
3. Insert push rods into recess in tappets.

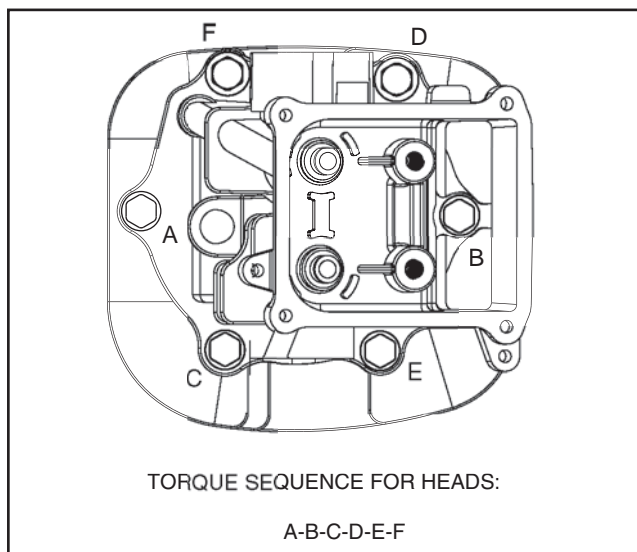


Figure 5-16.

**ADJUST VALVE CLEARANCE**

1. Set No. 1 cylinder at TDC, compression stroke.
  - a. Adjust rocker arms and check clearance (Figure 5-17).

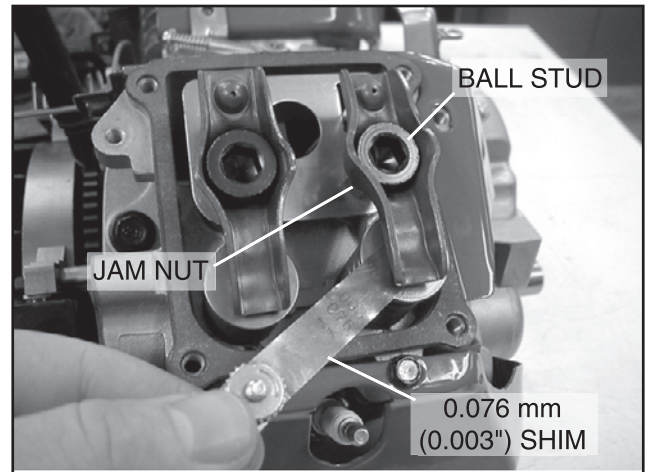


Figure 5-17. Adjust Valve Clearances

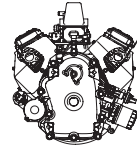
**Valve Clearance (cold) Intake and Exhaust 0.076 mm (.003").**

- a. Torque jam nut to 19 Nm (168 in. lbs.).
2. Repeat for No. 2 cylinder.
3. Install valve covers with new gaskets.
  - a. Torque screws to 6.8 Nm (60 in. lbs.).

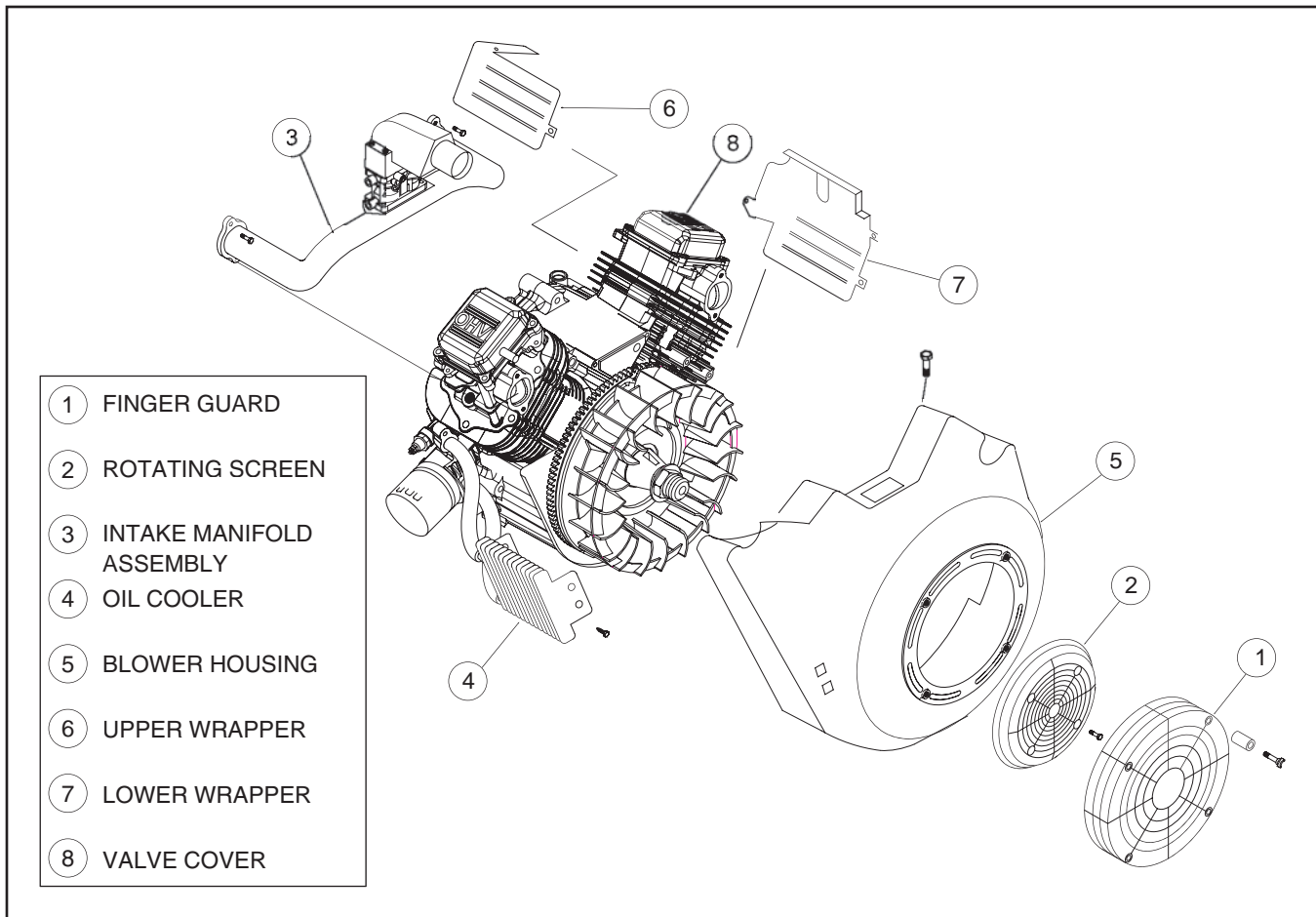
**REASSEMBLE**

1. Install cylinder wrappers.
  - a. Torque M5 screws to 2.8 Nm (25 in. lbs).
  - b. Torque M6 screws to 4.5 Nm (40 in. lbs).
2. Install spark plugs.
  - a. Torque to 19 Nm (168 in. lbs.).
3. Install exhaust manifold.
  - a. Torque screws to 19 Nm (168 in. lbs.).
4. Install blower housing.
  - a. Torque screws to 4.5 Nm (40 in. lbs).
5. Install intake manifold with new gaskets.
  - a. Torque screws to 19 Nm (168 in. lbs.).
  - b. Assemble governor link to carburetor.

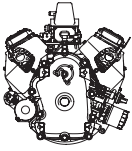
## SECTION 5: CYLINDER HEAD AND VALVES



6. Install rotating screen.
  - a. Torque screws to 1.9 Nm (17 in. lbs).
7. Install finger guard.
  - a. If engine is equipped with hex head screws, torque screws to 4.5 Nm (40 in. lbs).
  - b. If engine is equipped with finger screws, tighten screws by hand to approximately 1.3 Nm (12 in. lbs.).
8. Assemble air cleaner.
9. Make Static and Dynamic Governor adjustments as outlined on Page 4-3.



*Figure 5-18. General Assembly*



### GENERAL INFORMATION

The starter motor utilizes a solenoid, similar to an automobile starter, to assist in pinion gear engagement. When the starter motor is activated, the pinion gear engages a ring gear attached to the engine flywheel and cranks the engine.

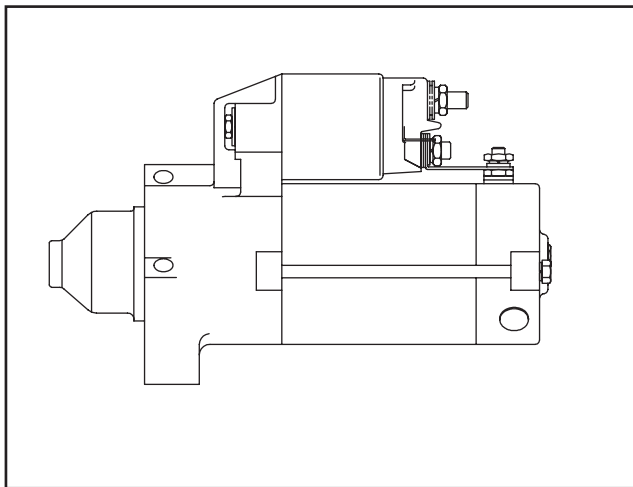


Figure 6-1. Starter Motor

### TROUBLESHOOTING

**NOTE:** If a starting problem is encountered, the engine itself should be thoroughly checked to eliminate it as the cause of starting difficulty. It is a good practice to check the engine for freedom of rotation by removing the spark plugs and flywheel guard and turning the crankshaft with a socket and ratchet or breaker bar, to be sure it rotates freely.

**WARNING:** DO NOT ROTATE ENGINE WITH ELECTRIC STARTER WHILE SPARK PLUGS ARE REMOVED UNLESS USING A COMPRESSION GAUGE. ARCING AT THE SPARK PLUG ENDS MAY IGNITE THE GASOLINE VAPOR EXITING THE SPARK PLUG HOLE.

#### ENGINE CRANKS SLOWLY:

- a. Additional load affecting performance (see note above).
- b. Discharged battery.
- c. Faulty electrical connection (battery circuit).
- d. Discharged battery (see alternators).
- e. Dirty or worn starter motor commutator, bearing, weak magnets, etc.
- f. Worn brushes or weak brush spring.
- g. Wrong oil viscosity for temperature expected.
- h. Battery leads too long or wire too small.
- i. Battery too small.

#### ENGINE WILL NOT CRANK:

- a. Faulty safety interlocks.
- b. Discharged or defective battery.
- c. Faulty electrical connections.
- d. Faulty starter motor switch (open circuit).
- e. Open circuit in starter motor.
- f. Brushes sticking, etc.
- g. Faulty solenoid.

#### STARTER MOTOR SPINS BUT DOES NOT CRANK ENGINE:

- a. Sticking pinion gear due to dirt.
- b. Damaged pinion or ring gear.
- c. Battery faulty or damaged.
- d. Incorrect rotation due to reversed motor polarity – all motors rotate counterclockwise viewed from pinion gear.
- e. Damaged solenoid

#### STARTER MOTOR SPINS BUT WILL NOT STOP:

- a. Defective starter switch.
- b. Solenoid stuck engaged.

### TEST EQUIPMENT

#### DIGITAL MULTIMETER:

A digital multimeter (VOM) may be used to read volts, ohms, amperes and test diodes (rectifiers), Figure 6-2.

**NOTE:** The Digital Multimeter is equipped with two fuses to prevent damage to the meter in the event that the input limits are exceeded. If the meter displays a reading of 0.00 when testing DC output, check fuses in meter. Refer to VOM operators manual for procedure for checking fuses.

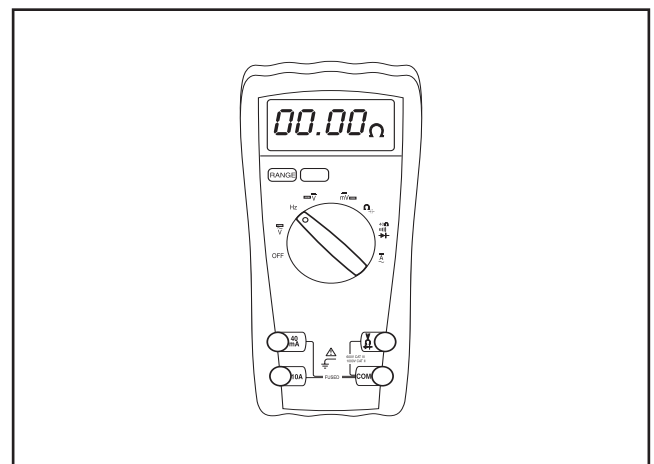
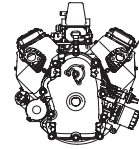


Figure 6-2. Digital Multimeter

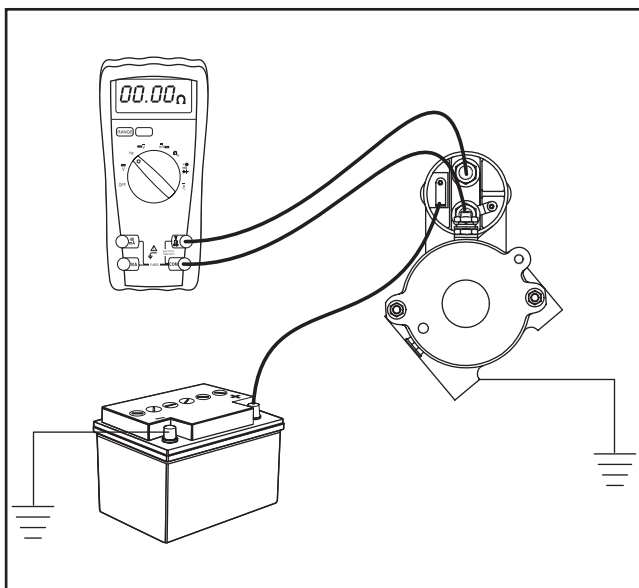


**TEST STARTER MOTOR**

TESTING STARTER SOLENOID:

The solenoid is a normally open, electrically activated switch. With the keyswitch in the "START" position, the switch closes, allowing battery current to flow to the starter motor and crank the engine.

1. The solenoid may be tested while mounted on the engine.
2. A jumper test lead is required for this test.
3. Remove positive battery cable from battery. Then remove battery cable from stud terminal on solenoid.
4. Disconnect wire from tab terminal on solenoid.
5. Keyswitch must be in "OFF" position.
6. Insert red test lead into **VΩ** receptacle in meter.
7. Insert black test lead into **COM** receptacle in meter.
8. Rotate meter selector to **▶ |||** position.
9. Attach one meter test lead to each stud terminal on the solenoid (Figure 6-3).
10. Attach one end of jumper lead to positive terminal on battery.
11. Touch jumper wire to tab terminal on solenoid.
  - a. An audible "Click" should be heard as the solenoid switch "closes."
  - b. Meter should make a continuous tone (continuity).



**Figure 6-3. Testing Solenoid**

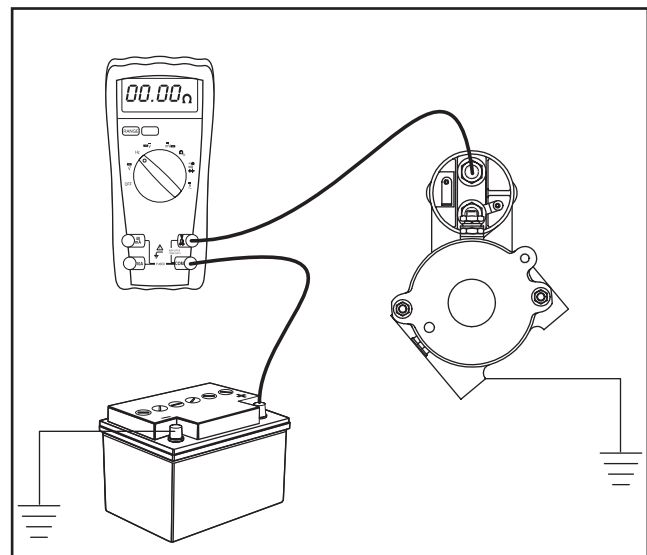
**CHECKING STARTER VOLTAGE DROP**

Before starting this test, make sure the battery is at least 70 percent charged (12.5 volts or higher). Also make sure the correct sized battery is being used. Check the engine manufacturer's Operator's Manual for battery size recommendations.

With the engine and all other accessories turned off, measure the battery voltage across the battery posts using a VOM set to the 20 Volt scale. Do not measure across the the battery wire terminal ends. Voltage should read 12.5 volts or higher.

Do not crank the engine longer than 15 seconds during any of the following tests. To check starter voltage drop:

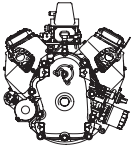
1. Prevent the engine from starting by either grounding the ignition at the ground stud on the side of the engine or removing the spark plug leads. Using a VOM, place the (+) positive lead on the positive post of the battery. The (-) negative lead on the negative post on the battery. Crank the engine and observe the reading on the VOM.
2. Next, place the (+) positive lead of the VOM on the starter's battery terminal stud and the (-) negative lead on the starter housing. Crank the engine and observe the VOM reading.
3. Compare the two voltage readings. If the two readings are the same (or a difference of one volt or less) then there is no excessive voltage drop on the positive side. If a voltage drop of greater than one volt is seen, proceed to Step 4.



**Figure 6-4. Testing Starter Voltage Drop**

4. Set the VOM on the 2 volt scale. Place the (+) positive lead on the (+) positive battery post and the (-) negative lead on the (+) positive terminal stud on the starter. Refer to figure 6-4. With the engine still disabled, crank the engine and observe the VOM reading. There should be less than a





0.2 volt drop. If greater, a check of each wire and terminal connection should be made. At each connection, no more than 0.2 volts should be seen.

5. Check the (-) negative side of the system. Place the VOM (+) positive lead on the starter case and the other lead on the (-) negative post of the battery. Crank the engine and observe the reading, it should be less than .2 volts.
6. If greater than 0.2 volts, check all wire connections on the (-) negative side of the starter. There should not be any readings higher than 0.2 volts.

### STARTER AMP DRAW TEST

This test requires a special tool called a clamp-on type amp meter. Most repair shops should be able to perform this test.

1. Place the amp meter clamp on the (+) positive cable running from the battery (+) post to the starter post.
2. Ground the ignition and crank the engine (no longer than 15 seconds). The starter amp draw should be around 200 amps during cranking.

Excessive draw could be caused by the following:

- Faulty starter. To verify this, the starter should be removed from the engine and bench checked prior to replacing. Do an amp draw test on the bench. The starter should not exceed 62 amps with a minimum pinion speed of 3250 rpm. See Figure 6-5.

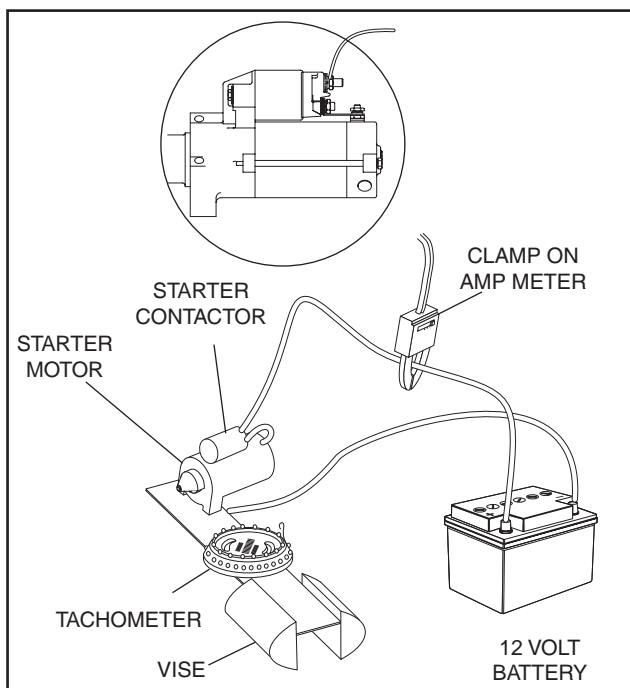


Figure 6-5. Testing Starter Motor Performance

- Engine oil viscosity too heavy (see engine manufacturer's Operators Manual).
- Some equipment manufacturers may use a constant drive pump, which may have too heavy of oil or too tight of belt tension.
- Internal engine problem. Turn the engine over with a socket and ratchet to make sure it turns over easily.
- Battery cable is loose or too small.
- Battery terminals are corroded.

### BATTERY INFORMATION

A 12 volt battery is used to operate the starter motor on Generac OHVI V-Twin engines. For best starter life and performance, the battery should have a rating of at least 450 cold cranking amps at 0°F.

**WARNING:** Wear eye protection when servicing the battery. Avoid skin contact. If contact does occur, flush with cold water and consult a physician.

**CAUTION:** Before servicing battery, disconnect negative (-) battery cable and then disconnect the positive (+) battery cable.

**WARNING:** Batteries produce hydrogen, an explosive gas. Do not store or charge a battery near an open flame or devices which utilize a pilot light or can create a spark.

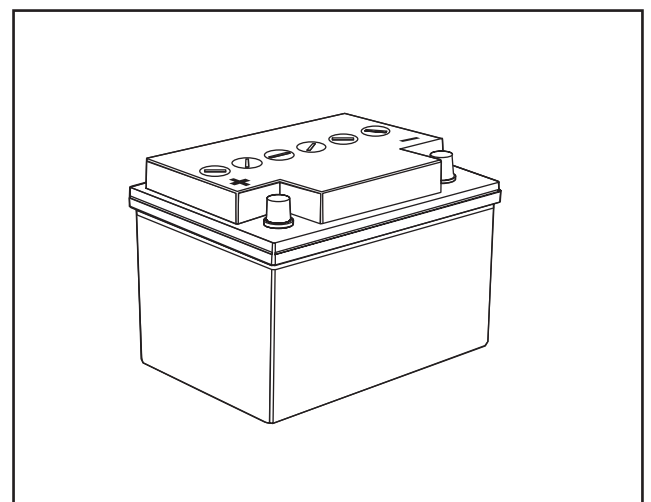
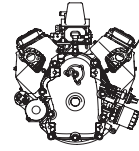


Figure 6-6. Typical Battery

#### INSTALLATION:

1. Before installing battery, connect all equipment to be operated.

## SECTION 6: ELECTRIC STARTER



- Place battery in holder with flat base. Tighten hold down evenly until snug. **DO NOT** overtighten.
- Connect positive terminal to positive post **FIRST** to prevent sparks caused by accidental grounding. Tighten connectors securely.
- Connect negative terminal to negative battery terminal. Tighten connectors securely.

### CHECKING BATTERY:

- Physical check – clean if necessary.
  - Corrosion
  - Dirt
  - Terminal and clamps (secure – good condition)
- Bring battery to full charge.

**WARNING:** DO NOT exceed charge rate of 1/10 ampere for every ampere of battery rating. Consult battery manufacturer for maximum charge recommendations.

- Use a "Trickle" charge (automatically reduces charge rate).
- Fill non-sealed battery cells with distilled water after charging (for batteries that have been in service).

**Note:** If battery gets "Hot" to the touch or is spitting acid (gassing) excessively, unplug charger periodically.

- With battery fully charged, check specific gravity readings of each cell with a Battery Hydrometer and record readings (Figure 6-5). All readings should be above 1.250 (compensating for temperature). If specific gravity readings varied 0.50 or if all cells read less than 1.225, replace battery.

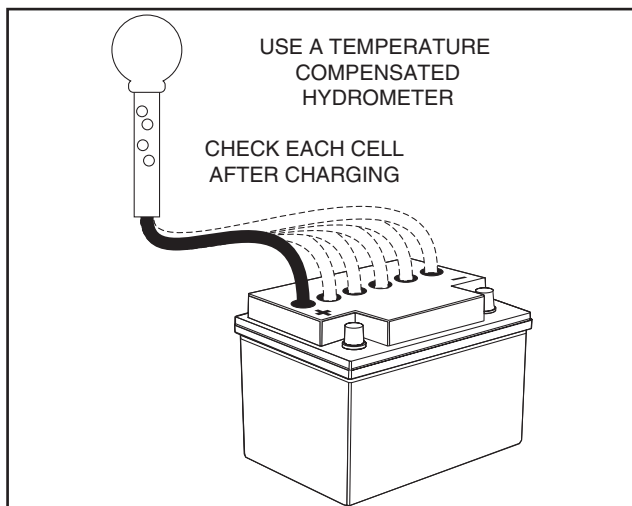


Figure 6-7. Checking 12 Volt Battery Cells

### TESTING BATTERY:

Set a digital multimeter to read DC Volts.

Attach RED meter test lead to positive(+) battery terminal. Attach BLACK meter test lead to negative (-) battery terminal. With ignition switch "OFF," press starter button. If ignition switch and starter switch are the same switch, disconnect wires from spark plugs and ground ignition using two Ignition Testers. Turn switch to "START." Meter should display 9 volts or more while cranking engine. If less than 9 volts is measured, replace battery.



**CAUTION:** Do not crank starter motor for more than 15 seconds without allowing starter motor to cool at least 2 minutes.

### BATTERY RECOMMENDATIONS:

The minimum battery size recommended is 450 CCA@0°F.

### BATTERY CABLE RECOMMENDATIONS:

These cable sizes are based on total length of cable from battery positive post to starter, plus ground return to battery negative post.

#4 AWG — 1.8 meters (6 ft.) or less

#2 AWG — 3.7 meters (12 ft.) or less

### OPTIONAL WIRE HARNESS

Engines supplied with a wire harness have a Packard four or five terminal female plug on the harness (see Figure 6-12). The wire harness consists of four colored wires as follows:

- A brown wire is used to signal low oil pressure. When low oil pressure is detected, this wire becomes a ground. Otherwise it is open.
- A yellow wire is used to ground the ignition. Connect this wire to ground and the ignition will be shut off.
- A white wire is connected to +12 Volts DC and the carburetor, which allows fuel to flow. Turn off the +12 Volt supply, and the fuel solenoid will close, stopping the flow of fuel.
- An orange wire (red on some models) is used to start the engine. Supply +12 Volts DC to this wire and the starter solenoid will engage. Turn off the +12 volt supply, and the starter will disengage.

Figures 6-8 through 6-10 show the proper connections for the wiring harness and how it is routed.

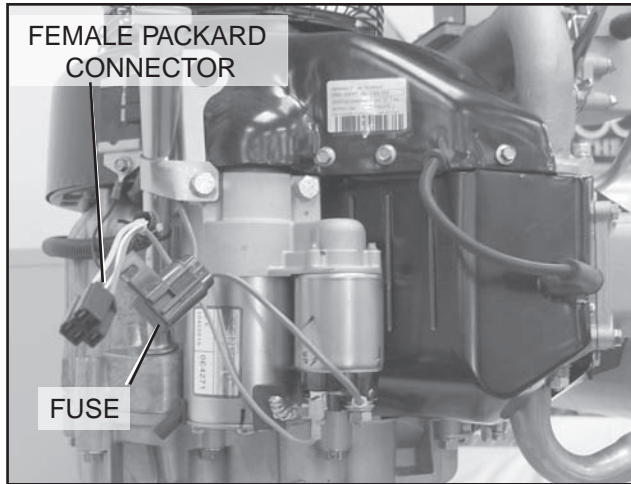
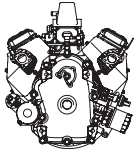


Figure 6-8. Vertical Shaft

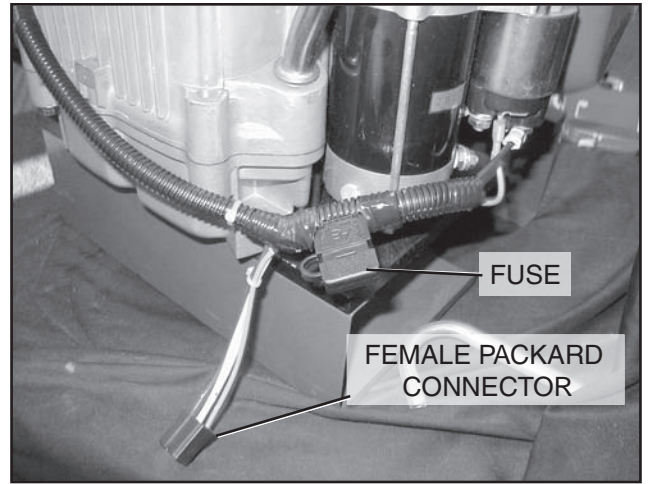


Figure 6-10. Horizontal Shaft



Figure 6-9.

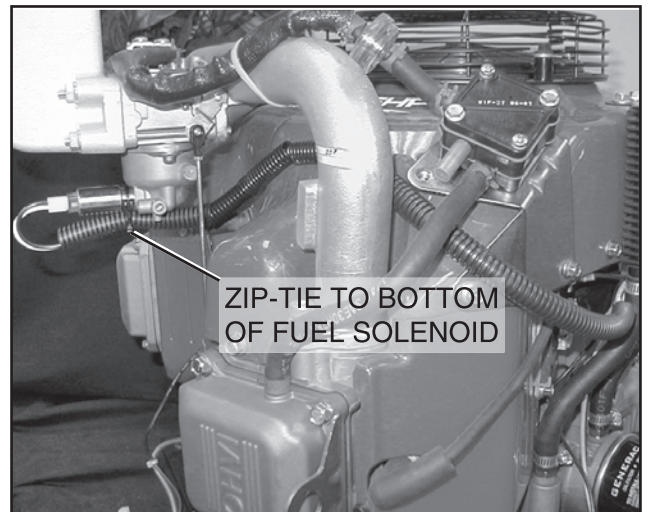
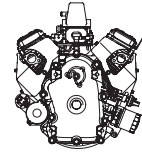
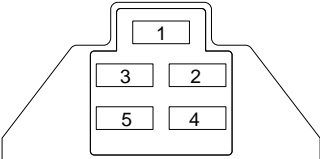
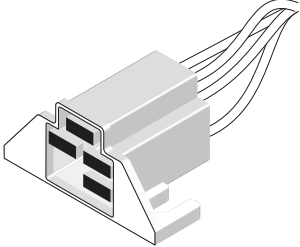


Figure 6-11.

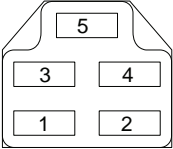
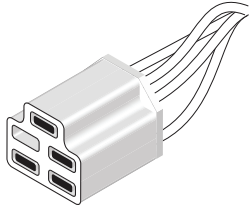


**WIRE HARNESS**  
(PACKARD CONNECTOR #03138080)

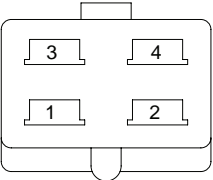
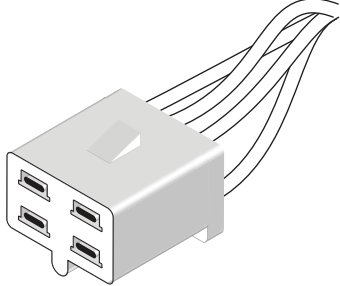
**LEGEND**  
 1 - IGNITION KILL TERMINAL - YELLOW  
 2 - STARTER SOLENOID - ORANGE  
 3 - CARBURETOR FUEL SOLENOID - WHITE  
 4 - LOW OIL PRESSURE SWITCH - BROWN  
 5 - OPEN

**WIRE HARNESS**  
(PACKARD CONNECTOR #2973422)

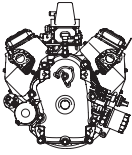
**LEGEND**  
 1. LOW OIL PRESSURE SWITCH - BROWN  
 2. IGNITION KILL TERMINAL - YELLOW  
 3. OPEN  
 4. CARBURETOR FUEL SOLENOID - WHITE  
 5. STARTER SOLENIOD - ORANGE

**WIRE HARNESS**  
(PACKARD CONNECTOR #2977048)

**LEGEND**  
 1 - IGNITION KILL TERMINAL - YELLOW  
 2 - BATTERY CHARGER - RED  
 3 - LOW OIL PRESSURE SWITCH - BROWN  
 4 - CARBURETOR FUEL SOLENOID - WHITE

*Figure 6-12. Optional Wire Harness Terminal Identification*



SECTION 6: ELECTRIC STARTER

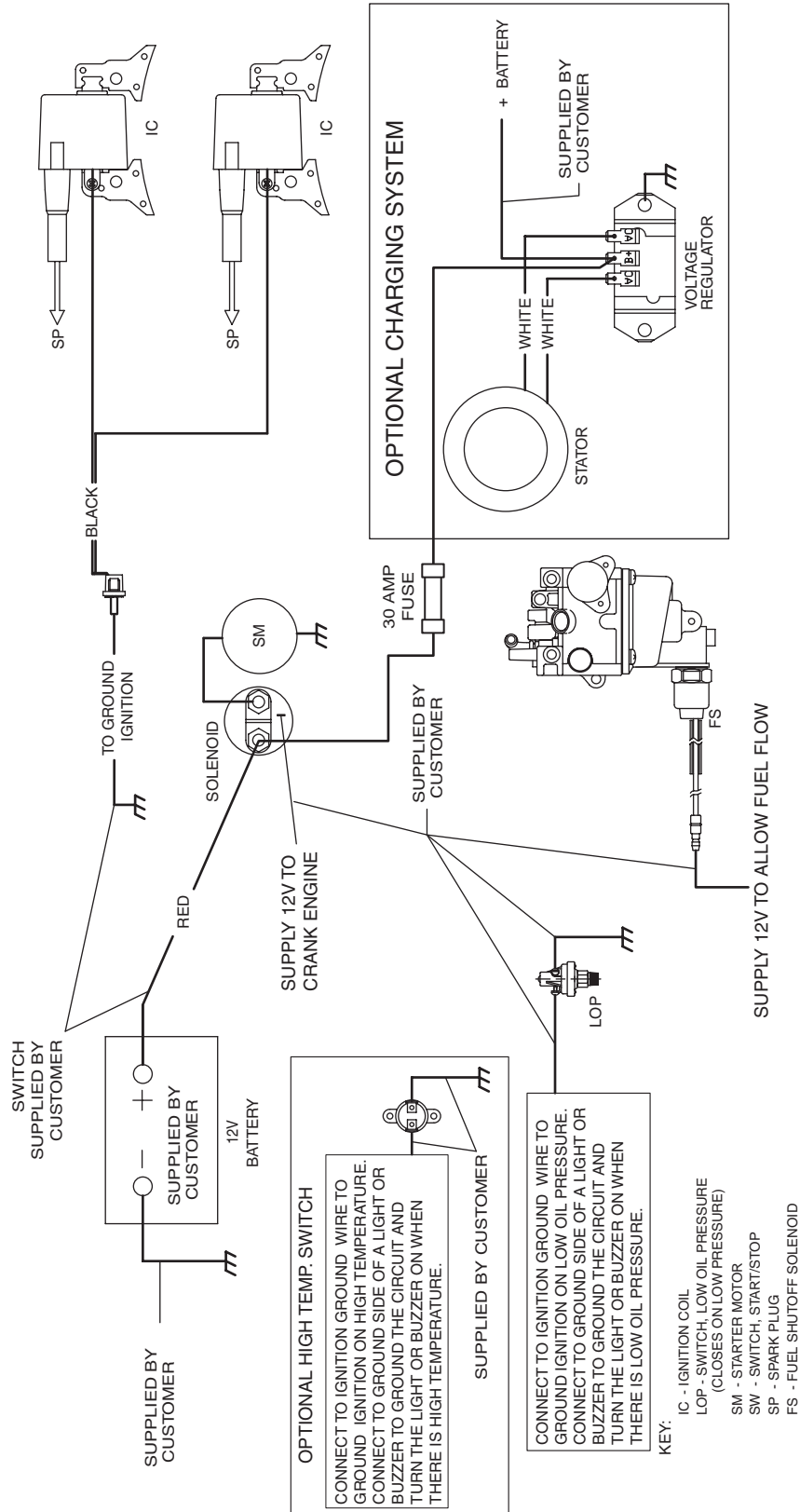
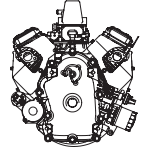
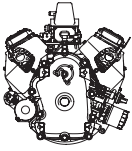


Figure 6-13. Typical 12 Volt Wiring Diagram

**NOTES**



A series of horizontal lines for taking notes, starting below the 'NOTES' header and extending across the width of the page.



### 20 AMP REGULATED ALTERNATOR

The 20 amp regulated alternator system provides AC current through two output leads to the regulator-rectifier. The regulator-rectifier converts the AC current to DC, and regulates the current to the battery. The charging rate will vary with engine RPM and temperature.

The stator, regulator-rectifier and flywheel are NOT interchangeable with any other alternator system.

**WHEN CHECKING THE ALTERNATOR COMPONENTS, MAKE THE TESTS IN THE FOLLOWING SEQUENCE:**

#### ALTERNATOR OUTPUT TEST:

Temporarily, disconnect stator wire harness from regulator-rectifier.

1. Insert RED test lead into  $V\Omega\rightarrow$  receptacle in meter.
2. Insert BLACK test lead into **COM** receptacle in meter.
3. Rotate selector to  $\tilde{V}$  (AC volts) position.



**CAUTION: ATTACH METER TEST LEADS TO AC OUTPUT TERMINALS (WHITE WIRES) BEFORE STARTING ENGINE. IF STATOR IS GROUNDED (DEFECTIVE), AND METER TEST LEADS CONTACT CENTER DC OUTPUT PIN, ARCING MAY OCCUR WHICH MAY DAMAGE WIRING.**



**Figure 7-1. Testing AC Output**

4. Attach RED and BLACK test lead probes to AC output terminals (white wires), as shown in Figure 7-1. (Meter test clip leads may be attached to either AC output terminal.)

5. With the engine running at 3600 RPM, output should be no less than:

#### **26 Volts - 20 Amp System**

6. If no or low output is found, check for bare wires or any other obvious defects. If "shorted" leads are not visible, replace the stator.

#### TESTING DC OUTPUT CHARGING WIRE:

A simple test may be performed to test the DC output charging wire circuit. If a problem exists in the wiring it can be corrected before testing regulator-rectifier.

Leave stator wire harness disconnected from regulator-rectifier.

Equipment keyswitch must be in OFF position.

1. Insert RED test lead into  $V\Omega\rightarrow$  receptacle in meter.
2. Insert BLACK test lead into **COM** receptacle in meter.
3. Rotate selector to  $\overline{V}$  (DC volts) position.
4. Attach RED test lead probe to DC output wire terminal (Red Wire), Figure 7-2.
5. Attach BLACK test lead probe to negative battery terminal.
6. Turn equipment keyswitch to ON position. Meter should display battery voltage.
7. If meter does not display battery voltage, check for blown fuse or broken or shorted wires.

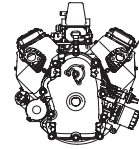


**Figure 7-2. Testing DC Output Wire**

#### TESTING REGULATOR-RECTIFIER:

1. Using a digital multimeter, test the battery voltage while the engine is NOT running.

## SECTION 7: ALTERNATORS

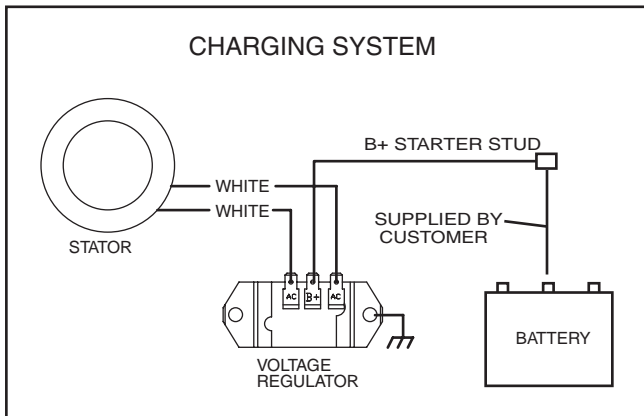


2. With the charging system properly connected, start the engine.
3. Bring the engine up to normal operating speed and test the battery voltage again.
4. If the battery voltage while the engine is running is greater than when the engine is stopped, the charging system is working.

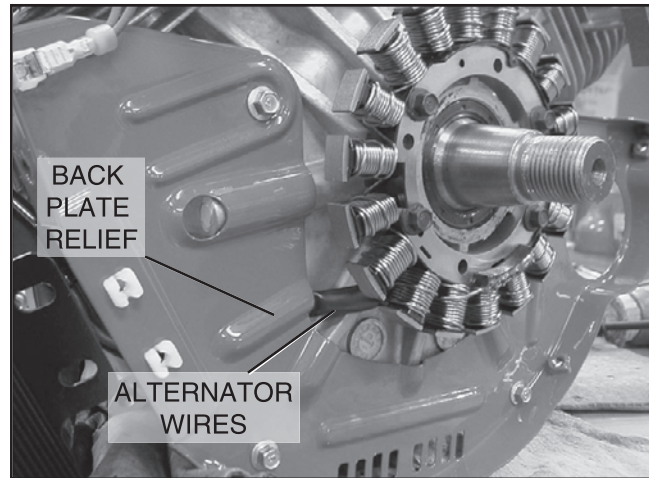
**Note:** *With the engine running, the battery voltage should be at least 13 Volts.*

### BATTERIES

**Note:** *See Section 6 for battery size and cable selection information.*

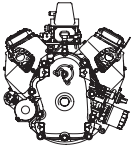


**Figure 7-3. Basic Charging System Schematic**



**Figure 7-4. 20 Amp Alternator**





### DESCRIPTION

The Generac GTH/GTV-760/990 OHVI V-twins use a full pressure lubrication system with an oil filter. The gerotor type oil pump draws oil from a screened oil pickup in the sump and pumps oil through the oil filter.

The filtered oil flows through an oil gallery in the sump and is distributed to the main bearings, connecting rod bearings and camshaft bearings. Engine oil pressure will vary with oil viscosity, ambient air temperature differences, operating temperatures and engine load. Follow the oil recommendation on page 8-2 of this section.

**Oil Pressure - @ 70° F (21 ° C):**

**15 - 50 psi (1.0 - 3.5 Bar)**

Two pressure relief valves limit the maximum oil pressure in the system to 60 and 40 psi respectively.

### PROTECTION SYSTEMS

#### LOW OIL PRESSURE SWITCH:

The engine is equipped with a low oil pressure switch that closes the circuit between the terminals when the oil pressure drops below 8 psi. If one terminal is connected to the ignition ground wire and the other terminal is connected to ground, the engine will shut down on low oil pressure. The switch can also be connected to an alarm or light to indicate low oil pressure, instead of shutting down the engine.

A delay built into the shutdown system on some engine applications allows oil pressure to build during starting. The delay allows the engine to run for about 10 seconds before sensing oil pressure. If the engine is wired for low oil pressure shutdown and the system senses low oil pressure during operation, the engine shuts down. The engine will not continue to run until 8 psi of oil pressure is reached. If you try to restart the engine within (five) 5 seconds after it shuts down, the engine may NOT start. The system needs 10 seconds to reset.

**NOTE: Some differences may exist between low oil pressure systems. Refer to the electrical schematic/wiring diagram in the Owner's Manual for the specific application using this engine.**

#### HIGH TEMPERATURE SWITCH (OPTIONAL):

This switch's contacts close if the temperature should exceed approximately 140° C (284° F), initiating an engine shutdown. In certain applications, the equipment will automatically restart and the LED will reset once the temperature has returned to a safe operating level.

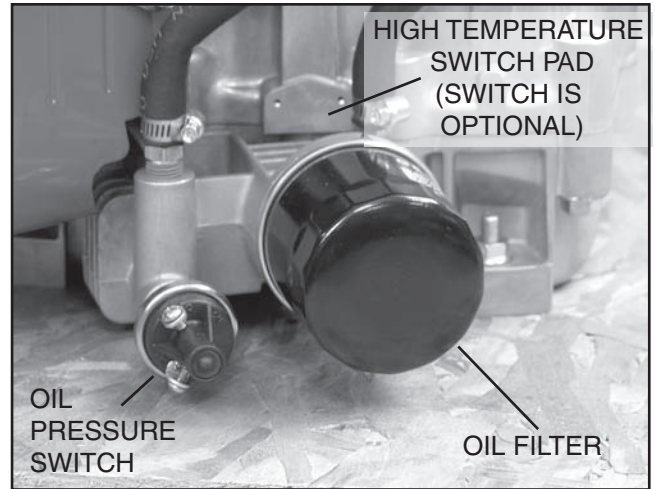


Figure 8-1. Engine Protective Devices

### CHECKING THE ENGINE OIL LEVEL

The oil capacity of the GTH/GTV-760/990 OHVI engine is approximately 2 quarts. Refer to the chart on Page 14-1 for the proper amount for each model. To check the engine oil level, proceed as follows:

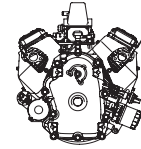
1. Remove the dipstick and wipe it dry with a clean cloth.
2. Install the dipstick completely; then remove it again. The oil level should be at the dipstick "Full" mark. If necessary, add oil until the "Full" mark is reached. **DO NOT FILL ABOVE THE "FULL" MARK.**



**Never operate the engine with the oil level below the "Add" mark on the dipstick. Doing this could damage the engine.**



Figure 8-2. Location of Oil Fill/Check (Vertical Shaft)



## CHANGING THE ENGINE OIL AND FILTER

### RECOMMENDED OIL TYPE:

Using the proper type and weight of oil in the crankcase is extremely important. Check the oil before each use and change the oil regularly (see Figures 1-1 through 1-5). Failure to use the correct oil, or using dirty oil, can cause premature engine wear and failure.

Use only high quality detergent oil rated with an API service classification SJ or higher (example: SL or SM). Do NOT use oil designated "for diesel engines only" (example: CD).

The recommended oil weights include the following:

- During summer months: SAE 30. An acceptable substitute is SAE 10W-30. After first oil change, synthetic oil is acceptable.
- During winter months: SAE 5W-30 or synthetic 5W-30. DO NOT USE SAE 10W-40. After first oil change, synthetic oil is acceptable.

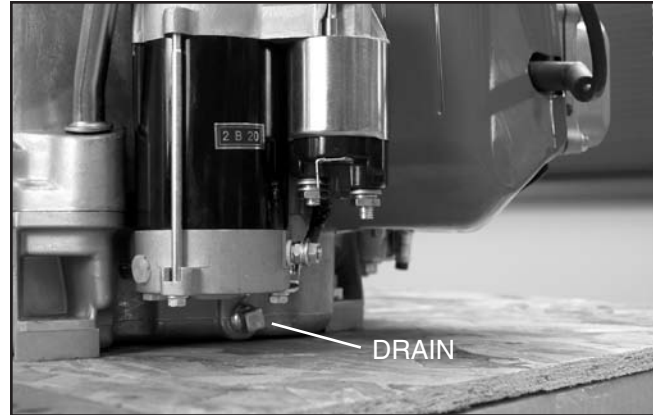
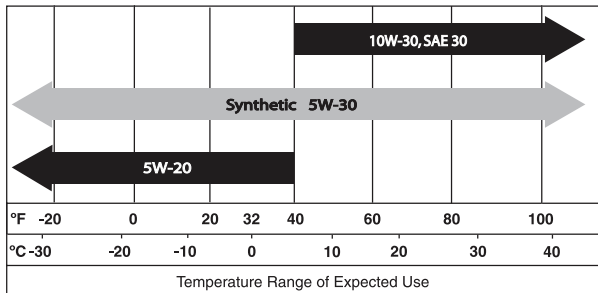


Figure 8-3. Oil Drain Location



Figure 8-4. Removal of Oil Filter



**Any attempt to crank or start the engine before it has been properly serviced with the recommended oil may result in an engine failure.**

### OIL CHANGE PROCEDURE:

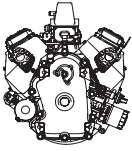
See "Section 14: Specifications" for crankcase oil capacities. Use no special additives. Make sure that the unit is level when filling with oil. DO NOT OVERFILL.

The engine is equipped with an oil filter. Change the oil and filter after the first eight (8) hours of operation. Change the oil and oil filter every 100 hours thereafter. If you are using this engine under dirty or dusty conditions, or in extremely hot weather, change the oil more often.

Use the following instructions to change the oil while the engine is still warm:

1. Clean the area around the oil drain plug, remove the plug and drain the oil completely into a suitable container (Figure 8-3).

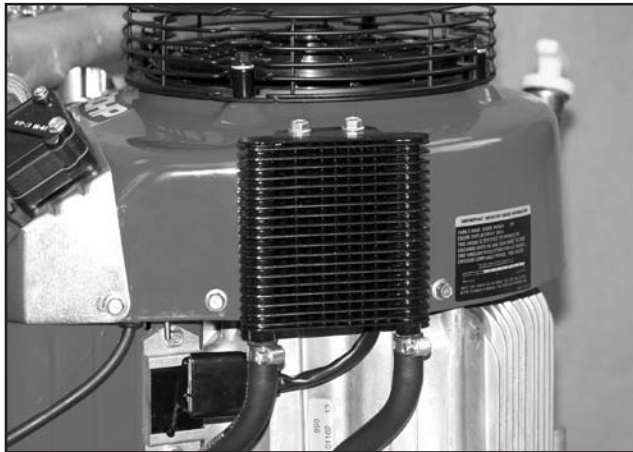
2. When the oil is drained, install and tighten the oil drain plug.
3. When changing the oil filter, use the following instructions:
  - a. Locate oil filter (Figure 8-4).
  - b. Place a suitable container beneath the oil filter and turn the filter counterclockwise to remove the filter.
  - c. Coat the gasket of a new filter with engine oil. Turn the new filter clockwise until the gasket contacts the filter adapter, then tighten an additional 3/4 turn.
4. Remove the oil fill cap and insert a clean funnel into the oil fill opening. Fill the crankcase with the recommended oil until the oil level is at the full point on the dipstick.
5. When the crankcase is filled to the proper level, install the oil fill cap. Start engine to fill oil filter, recheck/correct oil level.



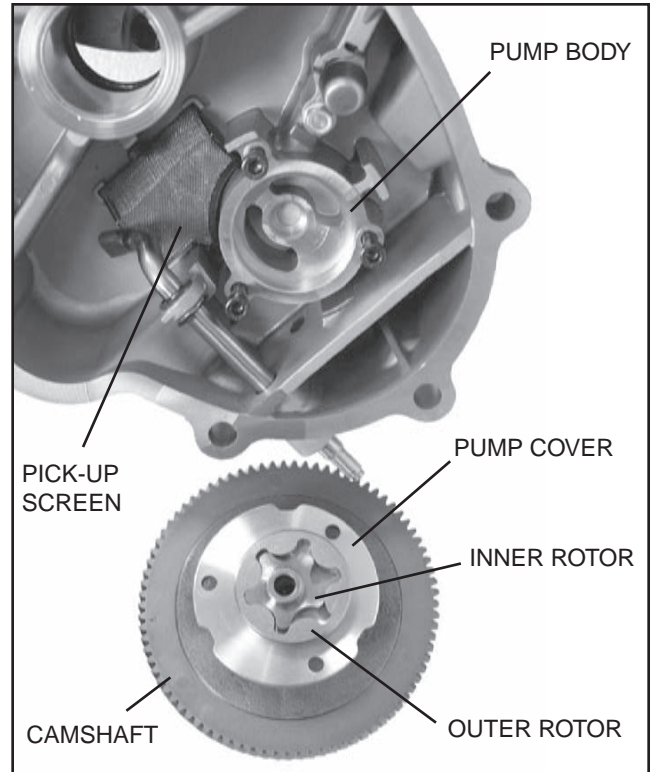
**OIL COOLER**

All GTH/GTV-760/990 V-Twin engines are equipped with an oil cooler, which is mounted on the blower housing. Forced air from the flywheel fan flows through the oil cooler fins dissipating heat from the engine oil (see Figure 8-5) .

The oil cooler fins should be cleaned every 100 hours (or more often under dusty conditions) and checked periodically for debris. Clean with compressed air or a soft bristle brush.



*Figure 8-5. Oil Cooler*



*Figure 8-6. Oil Pump, Vertical Engine*

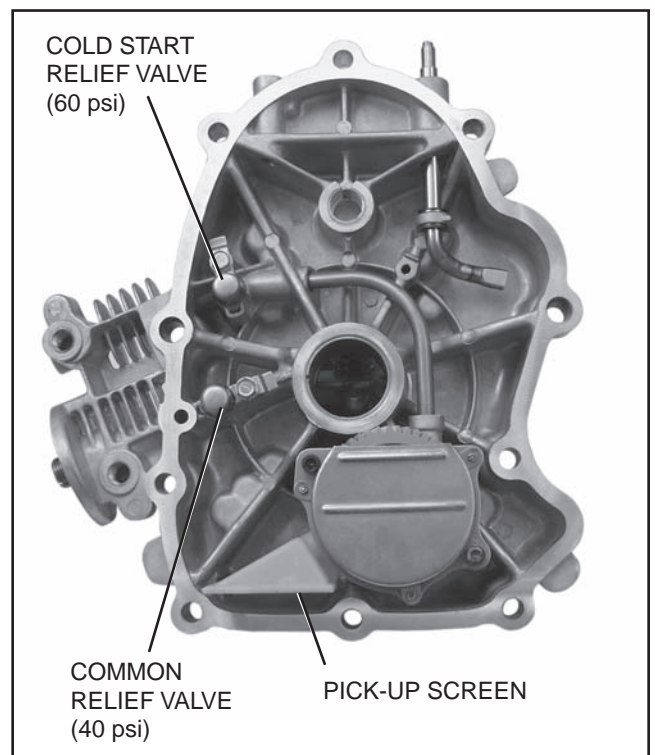
**OIL PUMP**

All Generac engines utilize a gerotor style oil pump which is classified as a positive displacement pump. Every revolution of the pump will displace a constant amount of oil. As the inner rotor turns, oil is drawn into the oil intake and fills the entire cavity between the inner and the outer rotor. As the gerotor continues to rotate, oil is moved from the intake port to the outlet port where the oil is pushed under pressure throughout the entire lubrication system (see Figure 8-6).

**PRESSURE RELIEF VALVES**

When a constant displacement pump is used, a relief valve is necessary to relieve the build-up of pressure in the system. Relief valves are needed because the pump supplies more pressurized oil than the system is able to use.

Generac uses two relief valves; a "Cold Start" and a "Common" valve. When the oil is cold and the engine is started, the oil pressure can reach up to 140 psi. To avoid damage to the oil filter and oil cooler, the "Cold Start" relief valve is installed in series immediately downstream of the oil pump and is set at 60 psi. After the oil goes through the oil cooler and filter, it flows through the "Common" relief valve. This relief valve is set at 40 psi and mainly regulates the pressure to the PTO journal and then throughout the rest of the oil system (Figure 8-7 and 8-8).



*Figure 8-7. Oil Pump, Horizontal Engine*

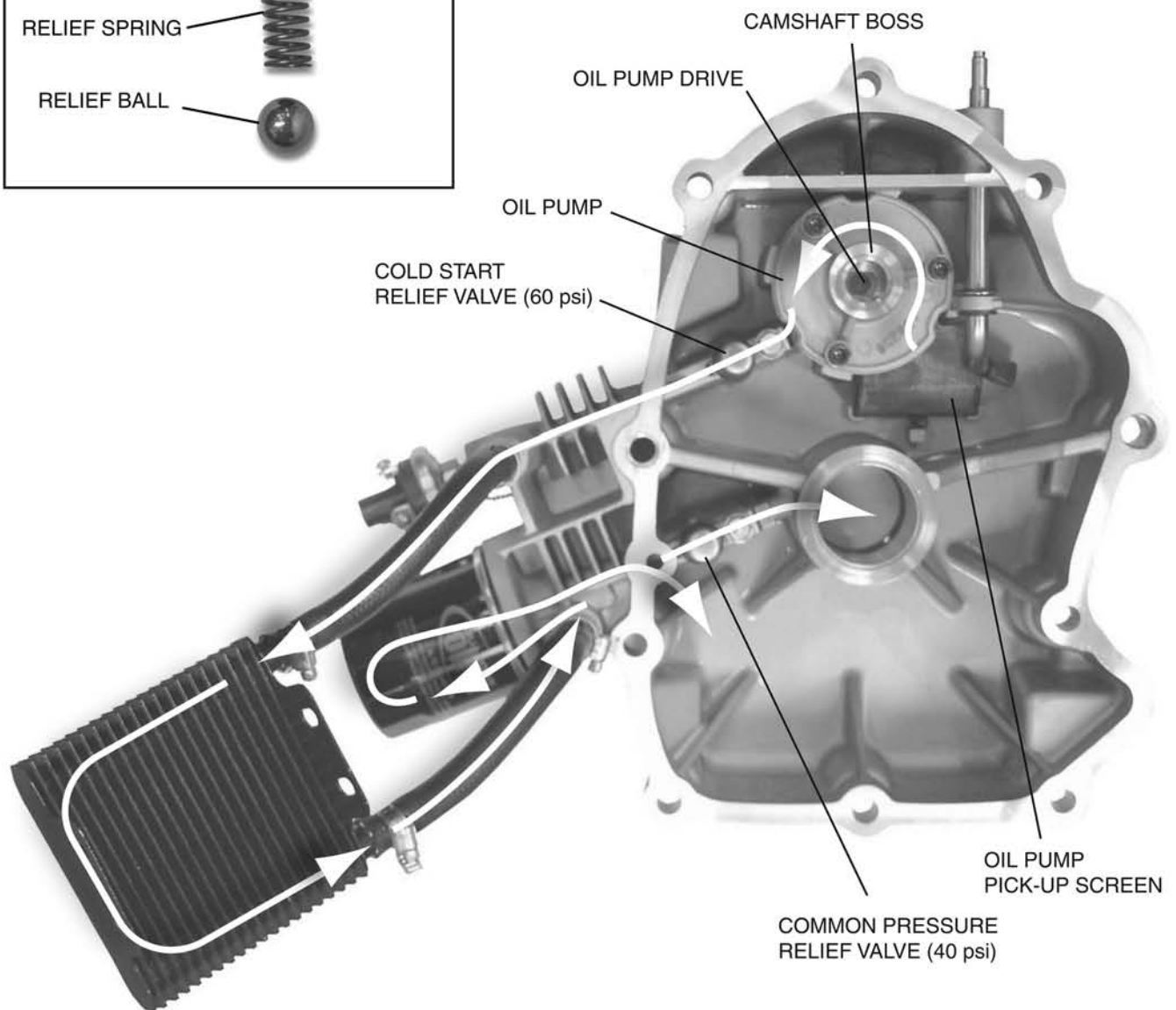
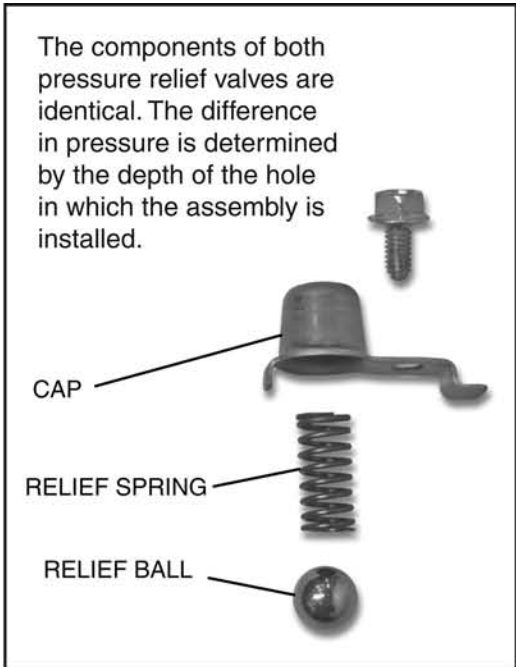
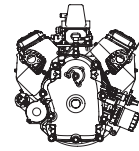
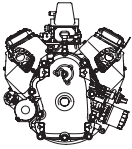


Figure 8-8. Typical V-twin Engine Oil Flow (Vertical Shaft Engine Shown)



### ENGINE DISASSEMBLY

Drain oil, remove oil filter and remove engine from equipment. Remove intake and exhaust systems. Remove engine shroud and all cylinder wrappers. Disconnect stop switch wires at ignition coils and remove ignition coils (see Section 2). Remove cylinder heads (see Section 5).

1. Remove the following parts (Figure 9-1):
  - a. Breather Assembly
  - b. Alternator
  - c. Backplate
  - d. Starter Motor
2. Remove crankcase cover/sump.
  - a. Discard gasket and O-ring.

3. Rotate crankshaft and camshaft until timing marks align and remove camshaft (Figure 9-2).

**Note: If necessary, place the engine flywheel side down to prevent tappets from catching on the camshaft.**

- a. Remove tappets.

**Note: Remove any carbon or ridge at the top of the cylinder bores to prevent breaking rings when removing piston and connecting rod assemblies.**

4. Remove No. 2 connecting rod cap and push connecting rod and piston assembly out through top of cylinder (Figure 9-3).

- a. Reassemble cap to rod to prevent interchanging.

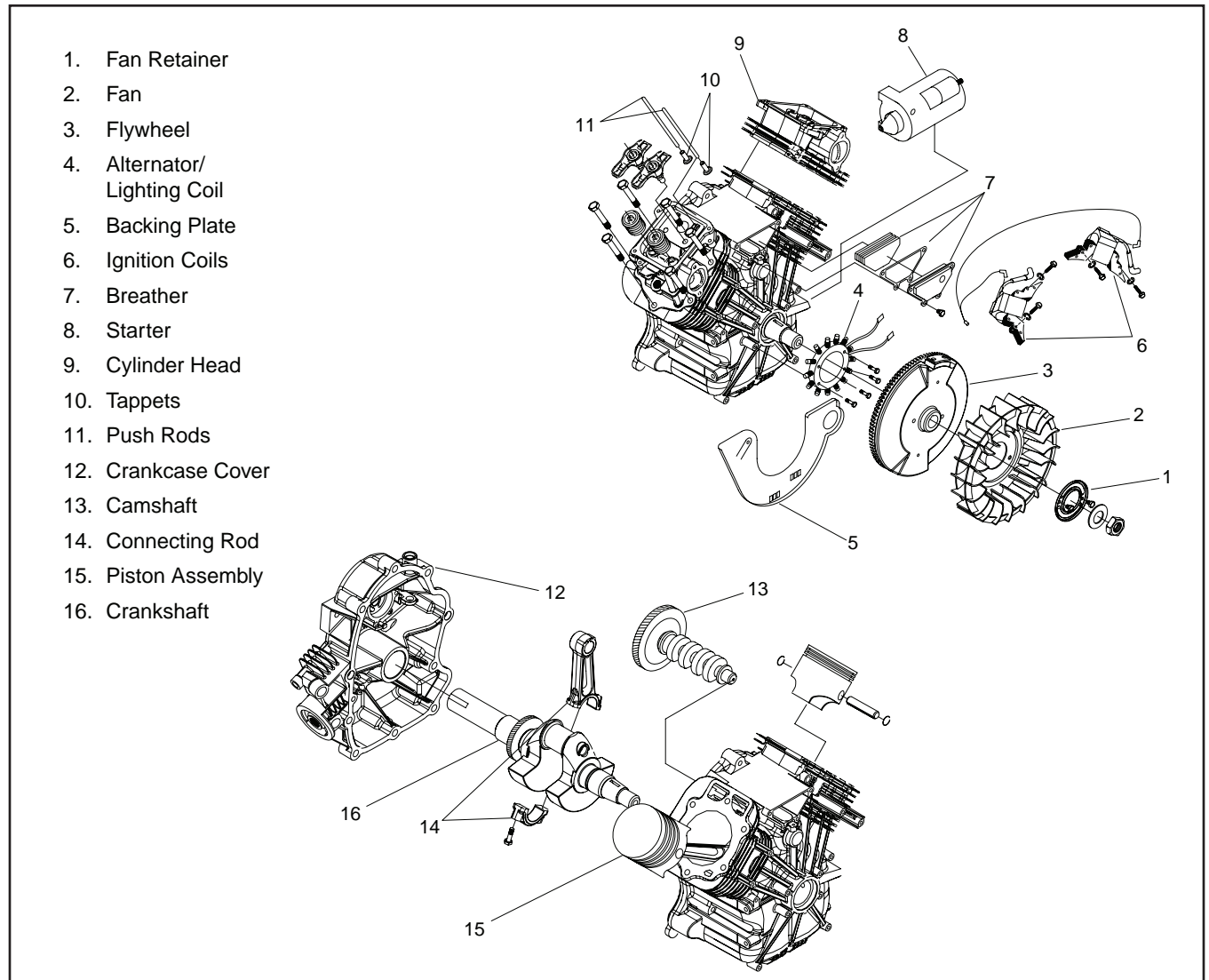


Figure 9-1. Partial View of Engine Breakdown

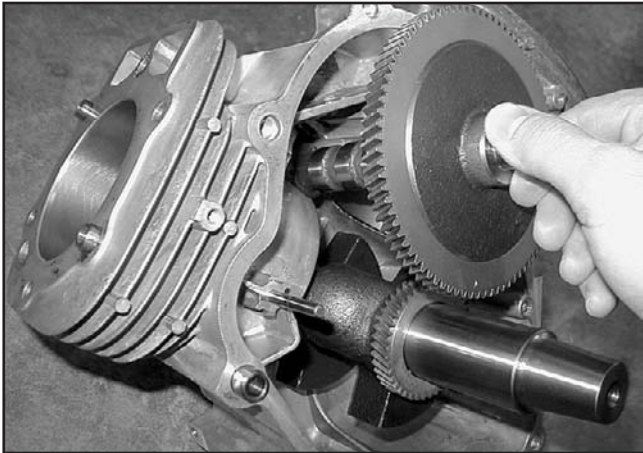
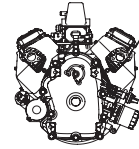


Figure 9-2. Remove Camshaft

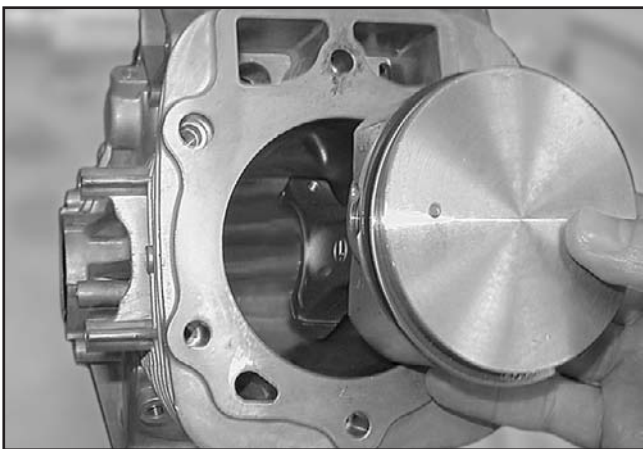


Figure 9-3. Remove Pistons and Connecting Rods

5. Repeat for remaining cylinder.
6. Remove crankshaft (Figure 9-4).

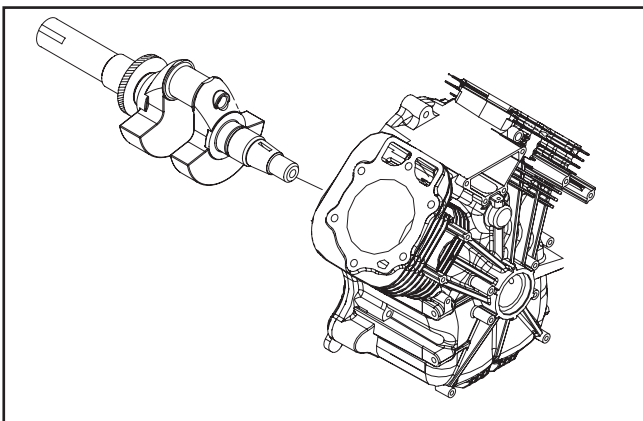


Figure 9-4. Remove Crankshaft

7. Remove oil pump from crankcase cover.

**Note:** Clean all surfaces of gasket material. Remove oil seals and thoroughly clean components in solvent. Organize components, keeping parts which are assemblies together.

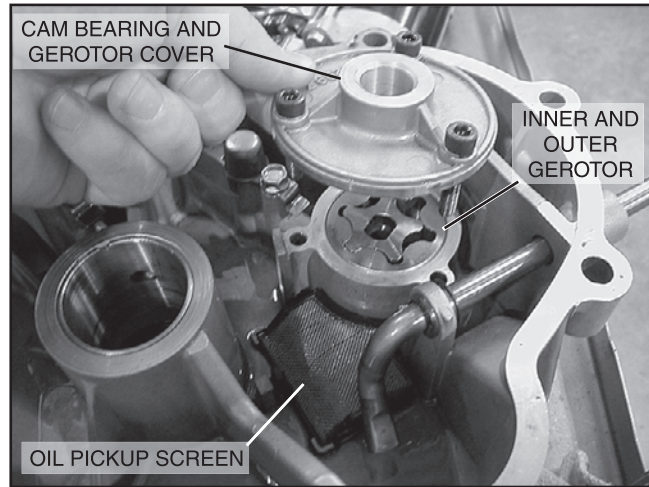


Figure 9-5. Remove Oil Pump (Vertical Shaft Engine)

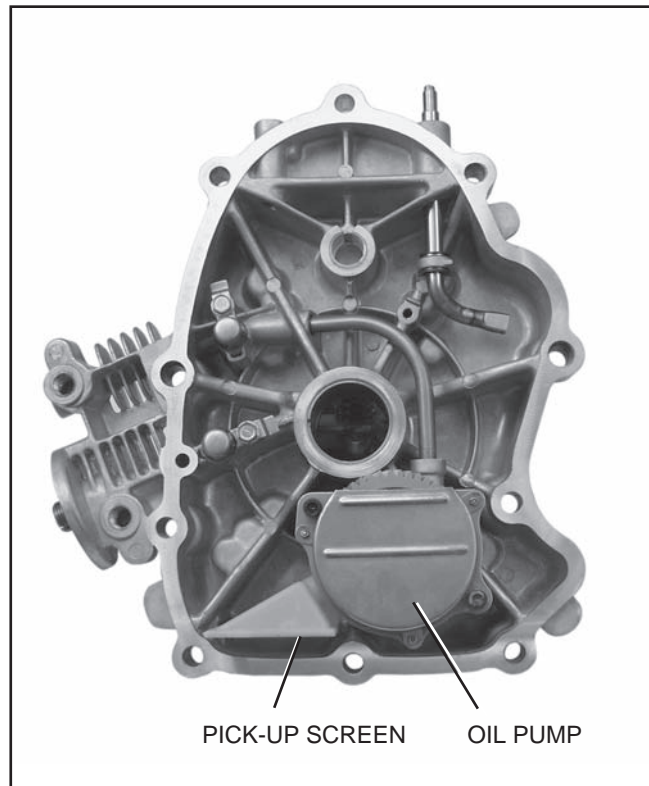
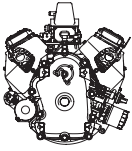


Figure 9-6. Remove Oil Pump (Horizontal Shaft Engine)

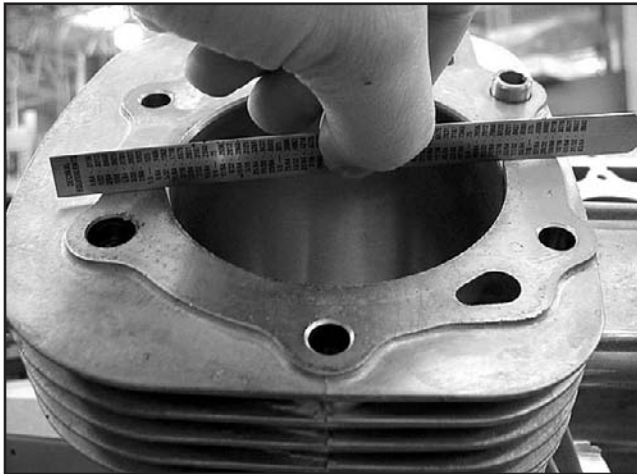


**CHECK CRANKCASE**

Check crankcase for cracks, stripped threads or broken fins. Check cylinder bores for damage or scoring.

1. Check cylinder head mounting surface for distortion with a straight edge, Figure 10-1.

If mounting surfaces are distorted more than 0.1 mm (.004"), the crankcase must be replaced.



**Figure 10-1. Checking Cylinder Head Mounting Surface**

2. Check cylinder bores for wear using a cylinder bore gauge or a telescoping gauge and dial caliper.

**Standard Bore Size: 90.00-90.025 mm (3.543-3.544")**

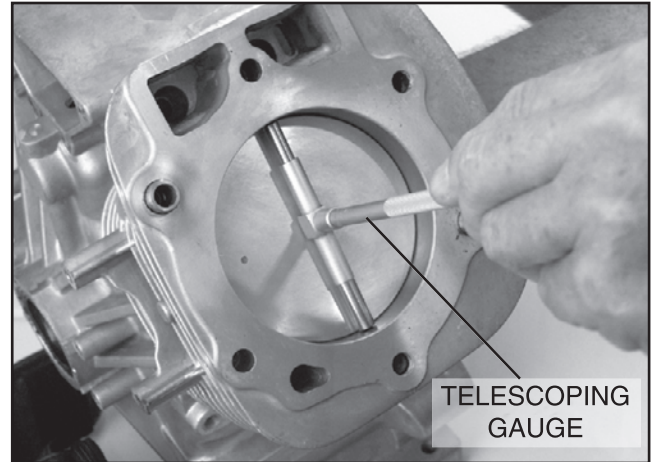
- a. Measure cylinder bore in 6 points at right angles as shown, Figures 10-2 and 10-3.
- b. If cylinder bore is worn more than 0.075 mm (.003") or more than 0.035 mm (.0015") out of round, it must be replaced.

**NOTE: If cylinder bores are within specification and show no signs of scoring or other damage, new piston rings may be installed providing the cylinder bores are reconditioned using a rigid hone with finishing stones, to restore the proper cross hatch angle in the cylinder bores. The proper cylinder cross hatch ensures proper lubrication and piston ring break in.**

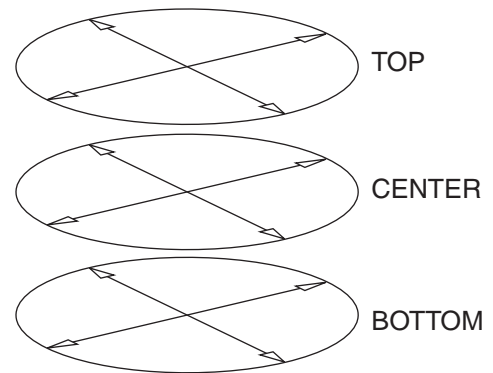
Refer to "Cylinder Finish (Cross Hatch)" for correct procedure for cross hatch honing.

RESIZING:

**Note: Oversize rings and pistons are NOT available. DO NOT bore or over hone cylinder.**



**Figure 10-2. Check Cylinder Bore**



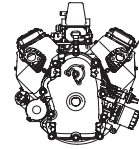
**Figure 10-3. Measure at Six Points**

CYLINDER FINISH (CROSS HATCH):

It is recommended that the cylinder bores be reconditioned to restore the cross hatch when new piston rings are to be installed in a cylinder that is within specification. Be careful not to hone oversize or it will be necessary to replace the crankcase.

Special honing stones are required when when reconditioning a cylinder bore. Honing stones will produce the correct cross hatch necessary for proper lubrication and ring seating. Honing is accomplished in a two step process called plateau honing. These steps must be followed carefully and should be performed by a competent machine shop. The correct cross hatch angle is approximately 45 degrees, Figure 10-4.

Honing is done with a variable speed 1/2", portable drill and a honing fixture. See Figure 10-10 for dimensions to make a honing fixture. Use two crankcase cover mounting screws to fasten the crankcase to the honing fixture, Figure 10-5.



Clamp honing fixture and crankcase securely in a vise at a convenient work height.

Place hone in middle of cylinder bore. Tighten adjusting knob with finger until stones fit snugly against cylinder wall. DO NOT FORCE. Cut a wood block and place inside crankcase to prevent hone from extending further than 3/4" to 1" (19 mm to 25 mm) below cylinder bore. Place hone drive shaft in chuck of portable drill and tighten. Be sure that cylinder and hone are centered and aligned with the drill spindle.

**NOTE: The first step in plateau honing requires a 220 grit diamond metalbond superabrasive stone (such as a Sunnen GMG55). Drill speed should be 240 RPM at 80 strokes per minute. Lubricate cylinder liberally to prevent build up on the honing stones. The second step requires a 800 grit diamond metalbond superabrasive stone (such as a Sunnen RMG807) at 110 RPM drill speed at 80 strokes per minute.**

**NOTE: Sunnen lubricating oil (SCC605) is recommended. Automatic transmission fluid is also an acceptable honing oil. Another acceptable honing oil can be made by mixing 4 parts 30 weight oil with 1 part kerosene.**

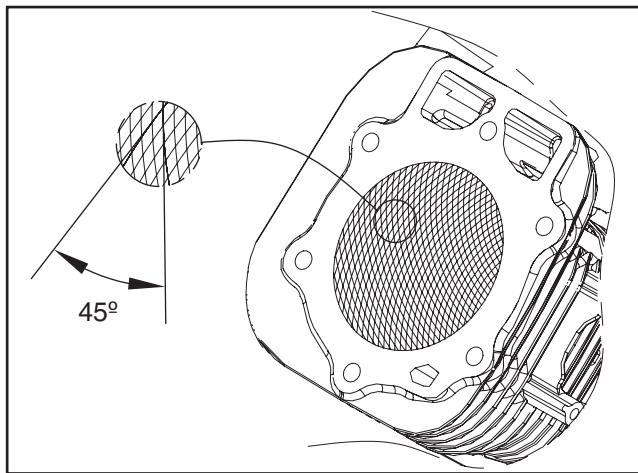


Figure 10-4. Cylinder Cross Hatch

CLEANING:

**IT IS VERY IMPORTANT THAT THE ENTIRE CYLINDER AND CRANKCASE BE THOROUGHLY CLEANED AFTER HONING.**

First wash the cylinder and crankcase carefully in a commercial solvent or kerosene. Then thoroughly wash cylinder and crankcase using a stiff brush with soap and hot water. Rinse thoroughly with hot running water. Repeat washing and rinsing until all traces of honing grit are gone.

Honing grit is highly abrasive and will cause rapid wear to all of the internal components of the engine unless it is completely removed.

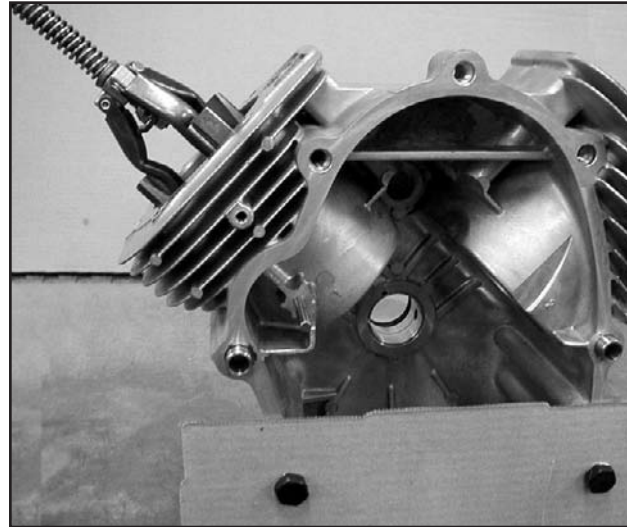


Figure 10-5. Honing Cylinders

**NOTE: When cylinder and crankcase have been thoroughly cleaned, use a clean white rag or napkin and wipe the cylinder bore. If honing grit is present it will appear as a gray residue on rag. If any honing grit is evident, re-wash and rinse entire cylinder and crankcase and check again. When there is no trace of honing grit on the rag, the cylinder is properly cleaned. Then oil cylinder bore to prevent rusting.**

**BEARINGS**

CHECK MAGNETO (FLYWHEEL END) BEARING:

Check magneto bearing for damage. Damaged bearings cannot be replaced. If not damaged, check for wear using a telescoping gauge and caliper (see Figure 10-6). Measure at several locations. If the measured diameter is larger than 38.25 mm (1.506"), the crankcase must be replaced.

The diameter of the crankshaft may also make it necessary to replace the crankcase. See Section 14 for the crankshaft measurement details.



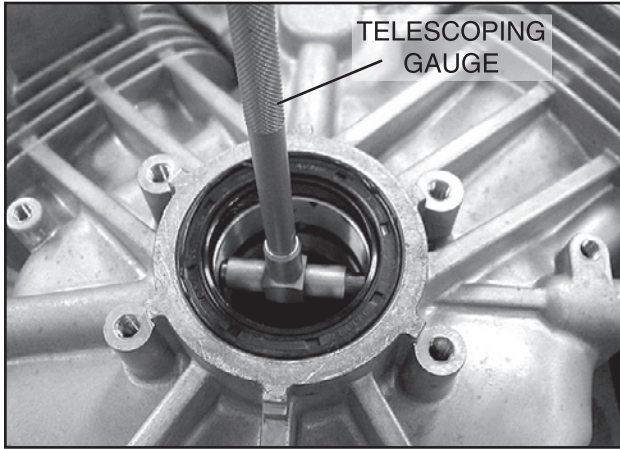
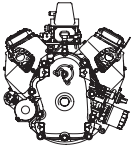


Figure 10-6. Check Magneto Bearing

CHECK PTO BEARING

The sump cover must be replaced if the bearing is damaged or if it measures larger than 42.25mm (1.663") in diameter (see Figure 10-7).

The diameter of the crankshaft may also make it necessary to replace the sump cover. See Section 14 for the crankshaft measurement details.

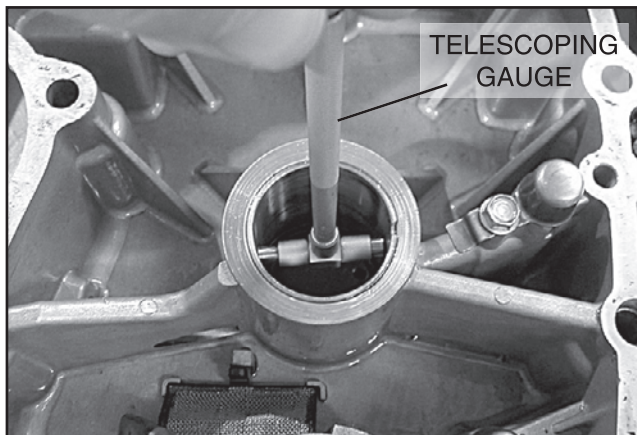


Figure 10-7. Check PTO Bearing

INSTALL PTO OIL SEAL:

Install a new PTO oil seal and press it in until it is 1.5mm (1/16") below the mounting surface.

CHECK CAMSHAFT BEARINGS

Use a telescoping gauge and caliper to check camshaft bearings. If camshaft bearings are worn, crankcase or crankcase cover must be replaced. (For vertical shaft engines, the gerotor cover must be replaced). See Figure 10-8.

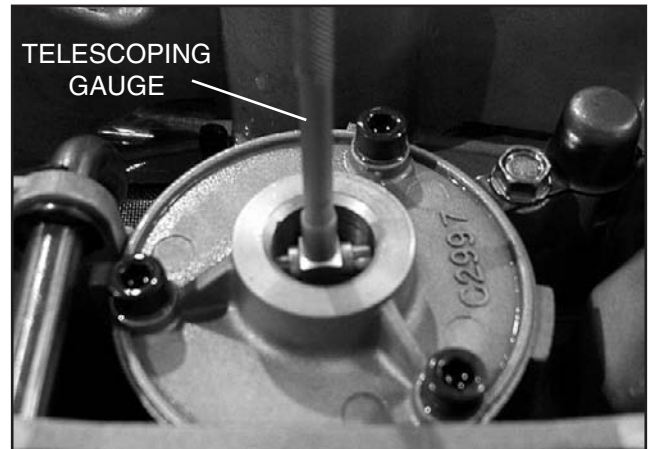


Figure 10-8. Checking PTO Side Camshaft Bearing

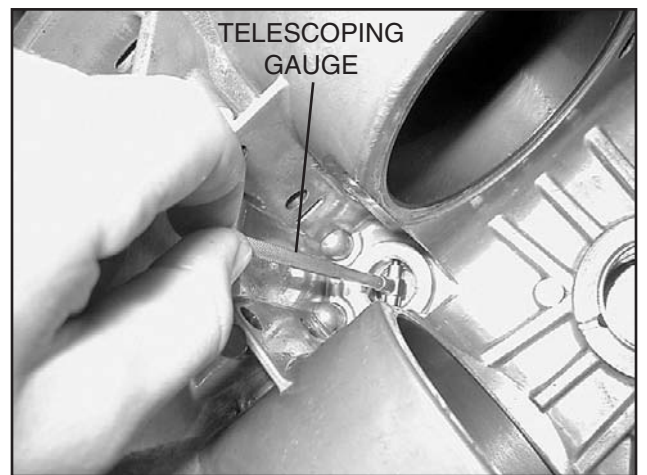


Figure 10-9. Checking Magneto Side Camshaft Bearing

OIL SEALS:

Always install new oil seals whenever engine is disassembled for major servicing or when repairing bearings. Lubricate sealing edge of oil seal with clean engine oil before assembly. Always use the correct seal protector to prevent damaging oil seal.

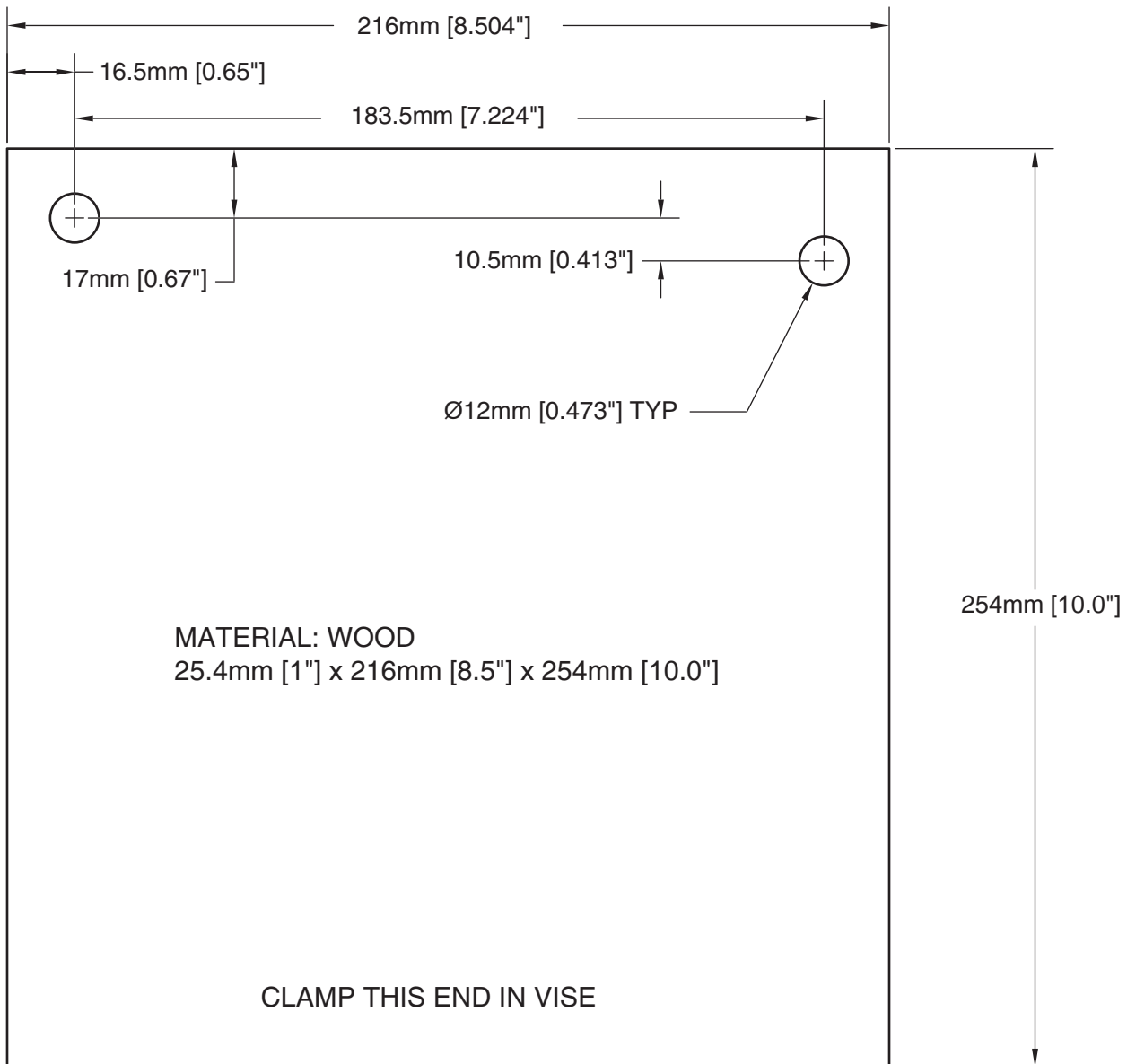
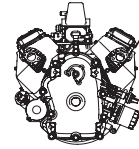
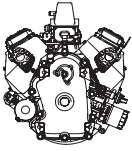
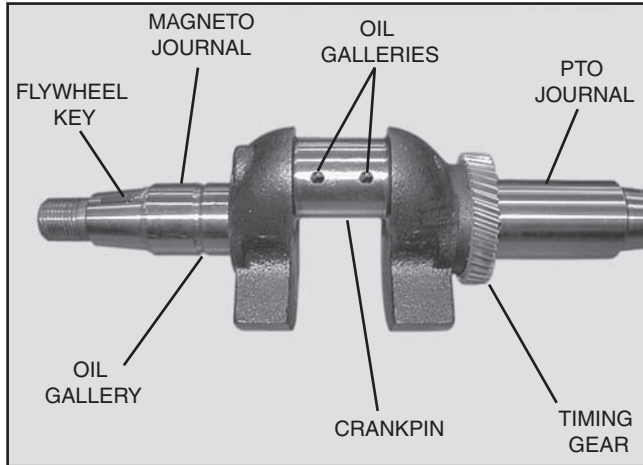


Figure 10-10. Honing Fixture



CHECK CRANKSHAFT:

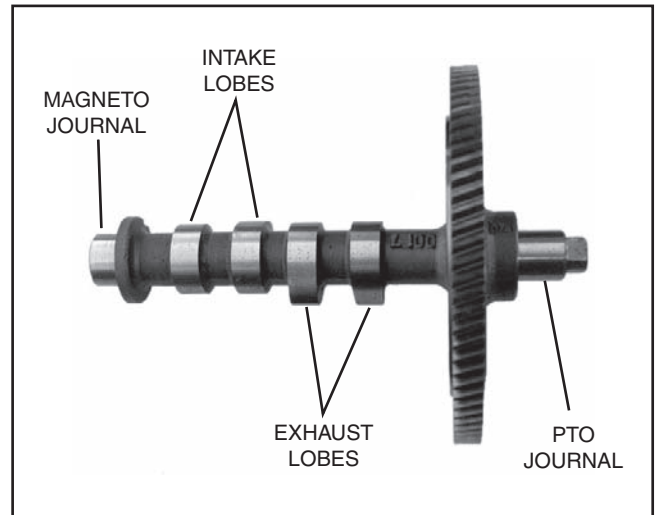
Inspect crankshaft threads, keyways and timing gear for damage or wear. If threads, keyways or timing gear are damaged or worn, replace crankshaft. Check journals for scoring. If journals are scored, replace crankshaft. Check journals for wear. See crankshaft reject sizes in Section 14.



**Figure 11-1. Check Crankshaft**

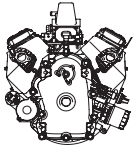
CHECK CAMSHAFT:

Inspect gear teeth, lobes and journals for wear and nicks (see Figure 11-2). Check journals and lobes for scoring and wear. Replace camshaft if not to specification noted in Section 14.



**Figure 11-2. Check Camshaft**





### GENERAL INFORMATION

It is recommended that new piston rings be installed whenever the engine is disassembled for major servicing or overhaul, providing that cylinder bores are within specification.

Measure cylinder bores before checking pistons and rings. See Section 10. If cylinder bores are out of tolerance, a new crankcase will be needed.

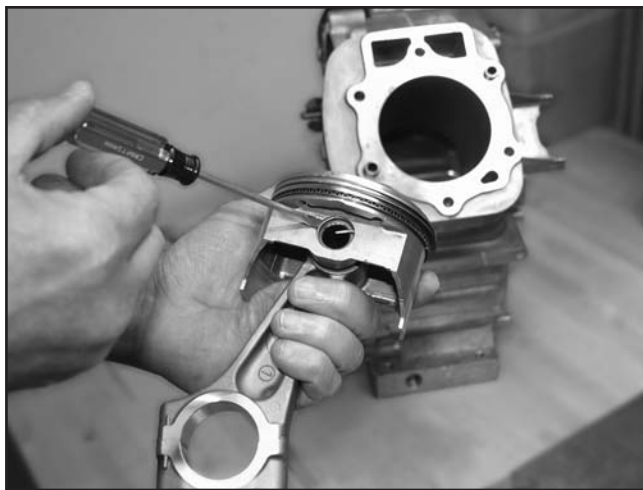
If the cylinder bore is more than .075 mm (.003") oversize, or 0.035 mm (0.0015") out of round, it must be replaced.

### DISASSEMBLE PISTON AND CONNECTING ROD

1. Remove piston compression rings using a ring expander similar to the one shown in Figure 12-1.
  - a. Then remove oil ring.



*Figure 12-1. Remove Rings*



*Figure 12-2. Remove Piston Pin Locks*

2. Disassemble piston from connecting rod, Figure 12-2.
  - a. Remove piston pin locks.
  - b. Piston pin is a slip fit in piston and connecting rod.Keep pistons and connecting rods together as an assembly. Do not mix.

### CHECKING PISTON AND RINGS

If the cylinder is not going to be replaced and the piston shows no signs of scoring, the piston should be checked. Carefully remove carbon from ring grooves.

1. Check side clearance of ring grooves using new rings, Figure 12-3. If a 0.10mm (0.004") feeler gauge for the compression rings or 0.20mm (0.008") for the oil ring can be inserted, the ring groove is worn. The piston must be replaced.



*Figure 12-3. Check Ring Grooves*

2. Check ring end gap, Figure 12-4.
  - a. Using a new ring, insert approximately 1" (25 mm) into cylinder.
  - b. If gap is less than the standard dimension, remove some material from the end of the ring to achieve the minimum gap.
3. Check piston pin bore, Figure 12-5.
  - a. Replace if greater than 20.03mm (.7886") or if it is 0.01mm (0.0005") out of round.

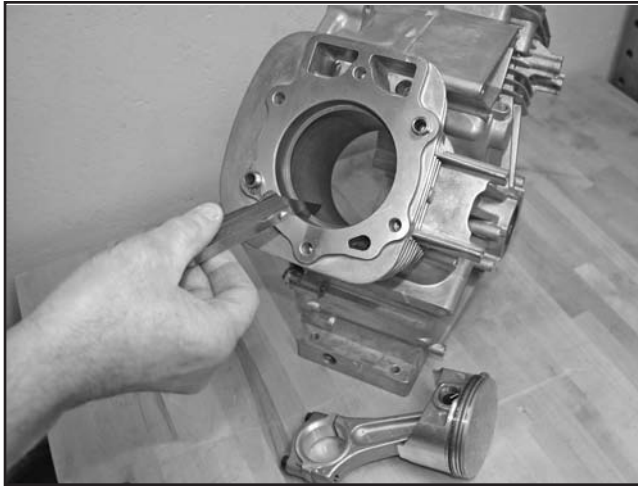
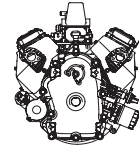


Figure 12-4. Checking Ring End Gap

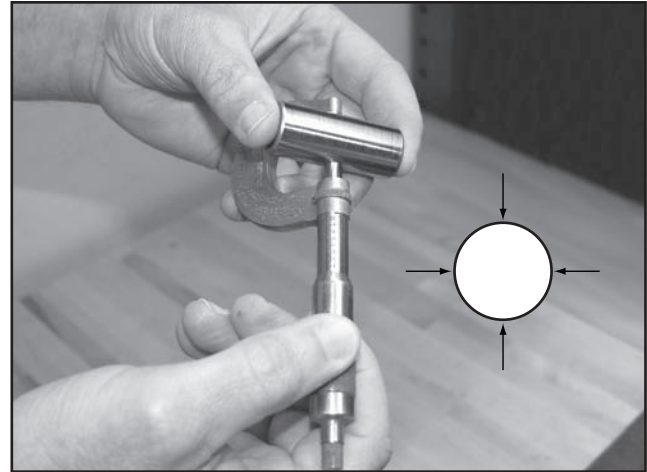


Figure 12-6. Check Piston Pin



Figure 12-5. Check Piston Pin Bore

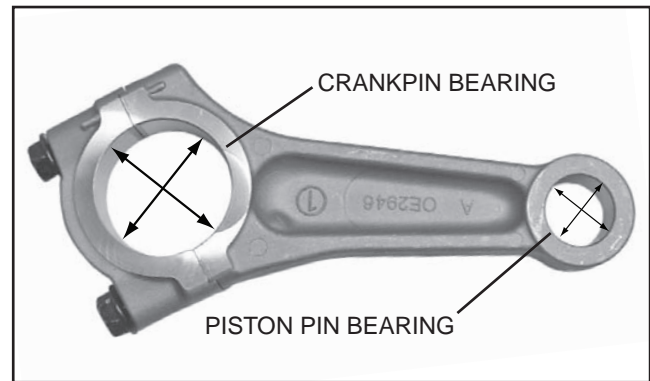


Figure 12-7. Check Rod Bearings

**ASSEMBLE PISTON AND CONNECTING ROD**

Lubricate parts with engine oil and assemble #1 piston and connecting rod, Figure 12-8.

1. Notch or casting mark on piston must be on flywheel side.
2. Number "1" on connecting rod must face PTO side (opposite notch or casting mark on piston).

a. Install piston pin locks with needle nose pliers.

Lubricate parts with engine oil and assemble #2 piston and connecting rod, Figure 12-9.

1. Notch or casting mark on piston must be on flywheel side.
2. Number "2" on connecting rod must face PTO side (opposite notch or casting mark on piston).

a. Install piston pin locks with needle nose pliers.

**CHECKING PISTON PIN AND CONNECTING ROD**

1. Check piston pin, Figure 12-6.
  - a. Replace if less than 19.97mm (.7862") or if it is .01mm (.0005") out of round.
2. Check connecting rod bearings (see Figure 12-7).

**Note: If piston pin or crankpin bearing ends are scored or worn the connecting rod must be replaced.**

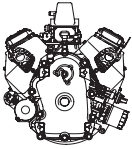


Figure 12-8. Assemble #1 Rod And Piston



Figure 12-9. Assemble #2 Rod And Piston

### ASSEMBLE PISTON RINGS TO PISTON

Install piston rings using ring expander when installing center and top compression rings.

1. Install oil ring expander.
  - a. Install lower oil scraper ring.
  - a. Install upper oil scraper ring.
2. Install center compression ring with chamfer up.
3. Install top compression ring.

**Note:** Top compression ring may be installed with either side up.

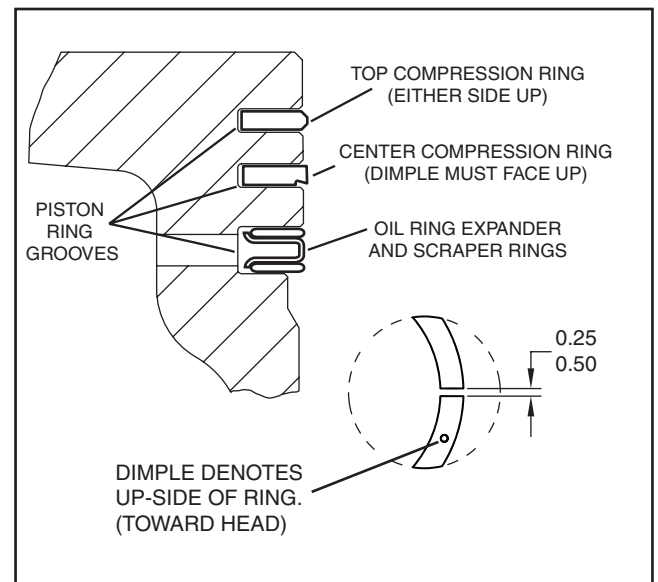
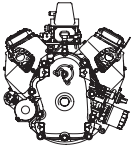


Figure 12-10. Piston Ring Installation







### INSTALL CRANKSHAFT

Lubricate magneto bearing and inside edge of oil seal with engine oil and install crankshaft.

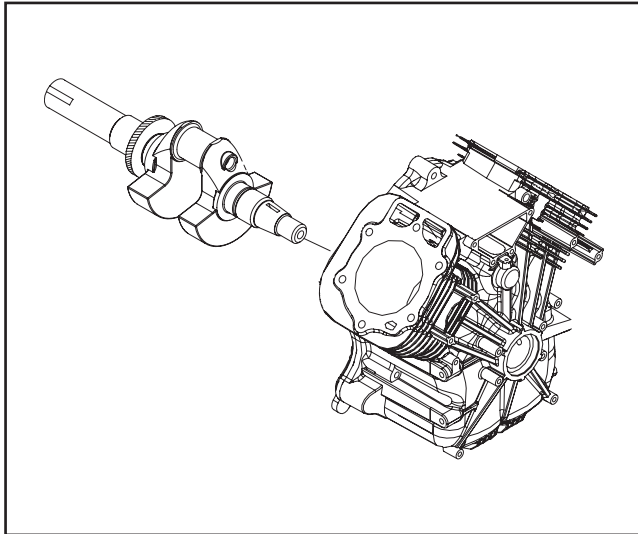


Figure 13-1. Installing Crankshaft

### INSTALL PISTON AND CONNECTING ROD

**Note: Install #1 piston and connecting rod first.**

1. Lubricate piston rings, piston skirt, and Ring Compressor, with oil.
  - a. Rotate the rings so that the ring end gaps are 90 degrees from each other.
  - b. Place piston inside of ring compressor and set upside down on bench with projections on compressor facing up Figure 13-2.
  - c. Tighten ring compressor evenly until rings are fully compressed.
  - d. Remove connecting rod cap.
2. Lubricate cylinder bores and crankpin and rotate crankshaft until it is at bottom of stroke.
3. Install #1 piston with notch or casting mark towards fly-wheel side, Figure 13-3.
  - a. Push piston down by hand, or with the handle of a hammer, until connecting rod is seated on crankpin.
4. Assemble connecting rod cap to rod with match marks aligned, Figure 13-4.
  - a. Torque screws to 24.4 Nm (216 in. lbs.).
5. Rotate crankshaft two revolutions to check for binding. Rod should also be free to move sideways on crankpin.

Repeat Steps 1-5 for #2 cylinder.

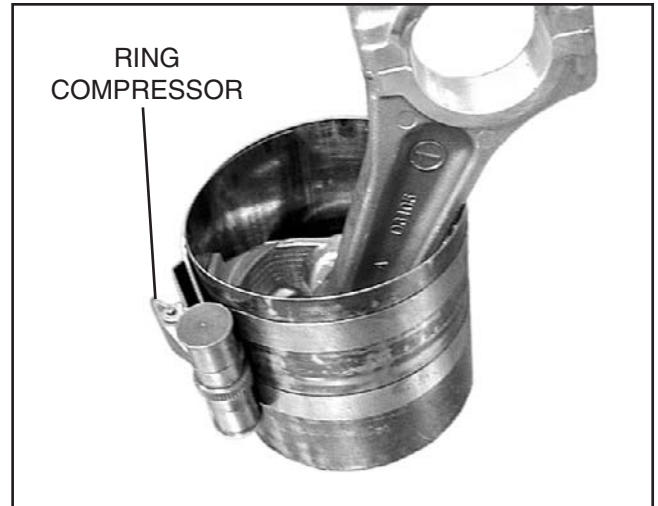


Figure 13-2. Compressing Rings

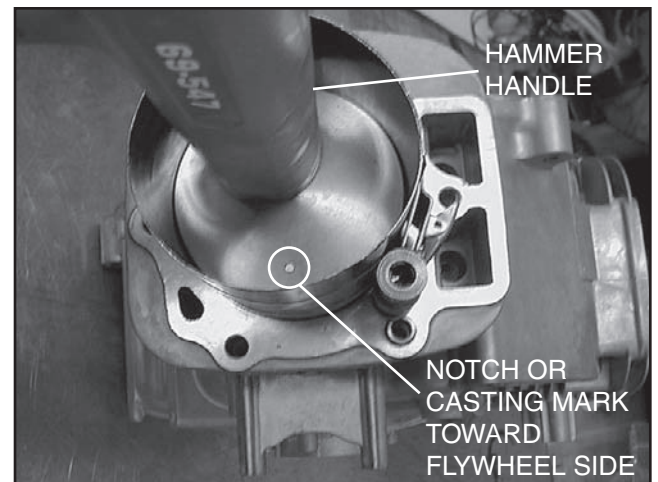


Figure 13-3. Installing Piston And Connecting Rod

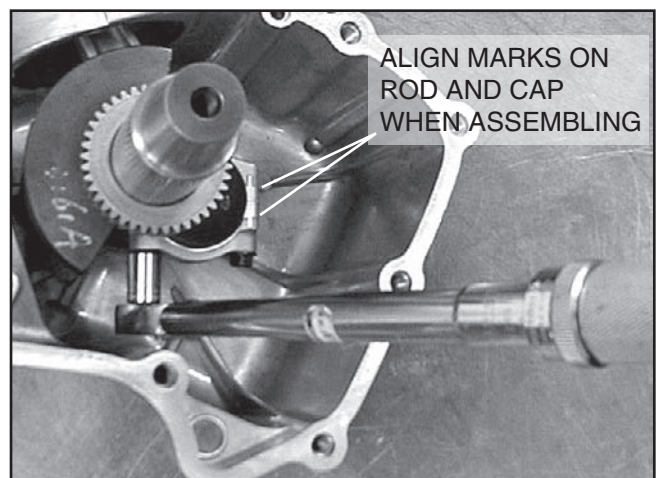
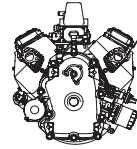


Figure 13-4. Torque Connecting Rods (#2 rod shown)



**Note:** The number 1 on #1 connecting rod and the number 2 on #2 connecting rod must be facing PTO side.

**Important:** Failure to use a torque wrench can result in loose connecting rod screws causing breakage or tight connecting rod screws causing scoring.

### INSTALL CAMSHAFT

Lubricate tappets, camshaft journals and lobes with engine oil.

1. Install tappets.
2. Align timing marks on camshaft and crankshaft gear and install camshaft, Figure 13-5.
3. Assemble governor spool to governor shaft.
  - a. Make sure that spool engages flyweights.
  - b. Clean all old gasket material from crankcase and cover.
  - c. Install new o-ring in crankcase, Figure 13-6.



Figure 13-5. Installing Camshaft

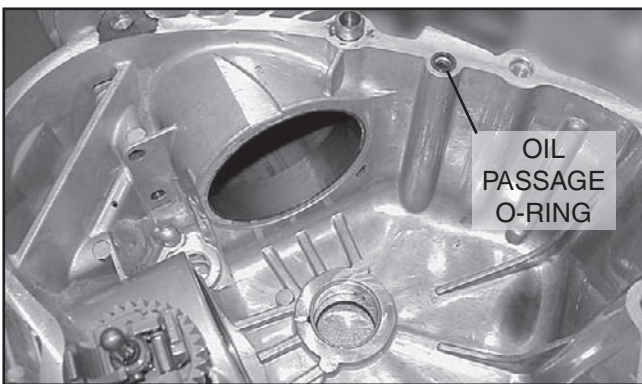


Figure 13-6. Crankcase Oil Passage O-ring

### INSTALL OIL PUMP

1. Lubricate gerotor and set in place.
2. Install oil pump cover.
3. Torque screws to 12.2 Nm (108 in. lbs.). See Figure 13-7.

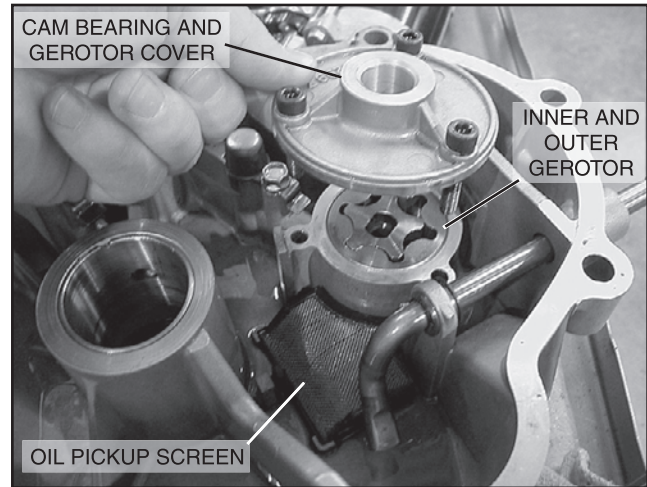


Figure 13-7. Installing Oil Pump

### INSTALL CRANKCASE COVER

Lubricate PTO seal and cam gear bearing.

1. Rotate governor shaft so that the paddle rests against the oil pump pick-up, Figure 13-8.

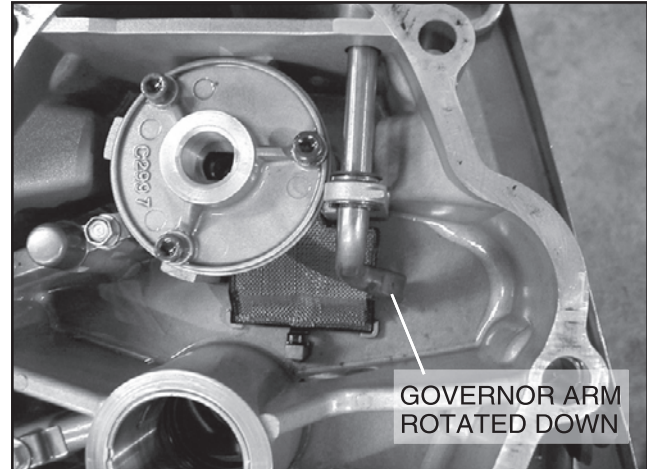


Figure 13-8. Rotating Governor Shaft

2. Install crankcase cover with new gasket.

**Note:** If the oil pump drive is not aligned, the cover will not slide completely on. Turning the crankshaft may align the oil pump drive.

3. Install governor support bracket.
  - a. The allen head crankcase bolt will need to be backed off.
4. Torque screws in sequence shown to 47.5 Nm (35 ft. lbs.), Figure 13-9.
5. Check crankshaft end play. If less than 0.05mm (.002") there may be an assembly problem.

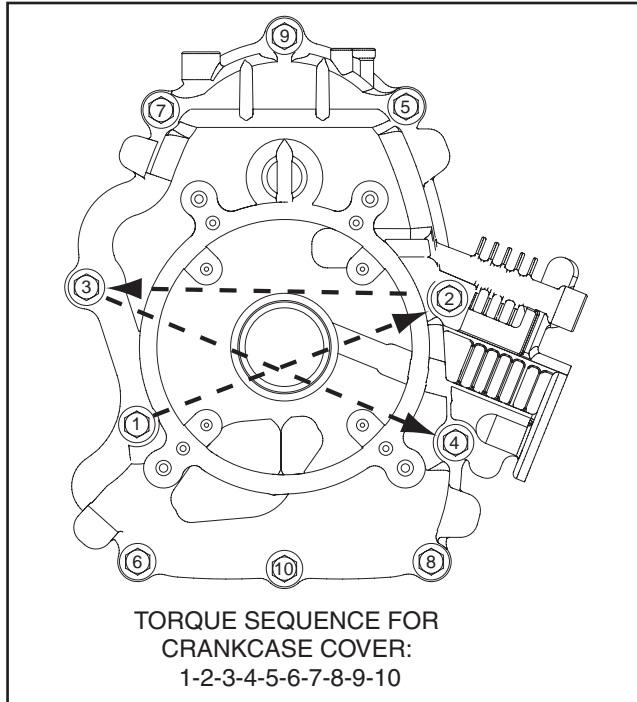
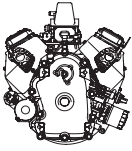


Figure 13-9. Crankcase Screw Torque Sequence

### INSTALL ALTERNATOR AND IGNITION COILS

1. Install alternator, Figure 13-10.
  - a. Torque screws to 4.75 Nm (40 in. lbs.).

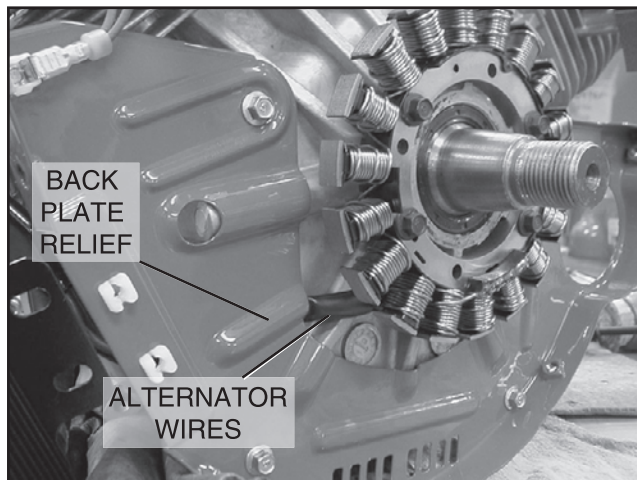


Figure 13-10. Install Alternator

2. Install back plate.
  - a. Torque screws to 4.75 Nm (40 in. lbs.).

**Important:** Route alternator wires through relief in back plate. DO NOT pinch wires.

3. Install starter motor.
  - a. Torque screws to 27 Nm (228 in. lbs.).
4. Assemble ignition coils to engine, Figure 13-11.
  - a. Mounting holes in coil are slotted. Push coil as far back as possible and tighten one screw to hold coil in place.
5. Repeat for second coil.

**Note:** The side shown in Figure 13-11 must face up on both coils or the engine will not function properly.

6. Install ground wire onto tab terminal on ignition coils.

**Important:** Make sure wires are routed over coil mounting posts and under breather tube.

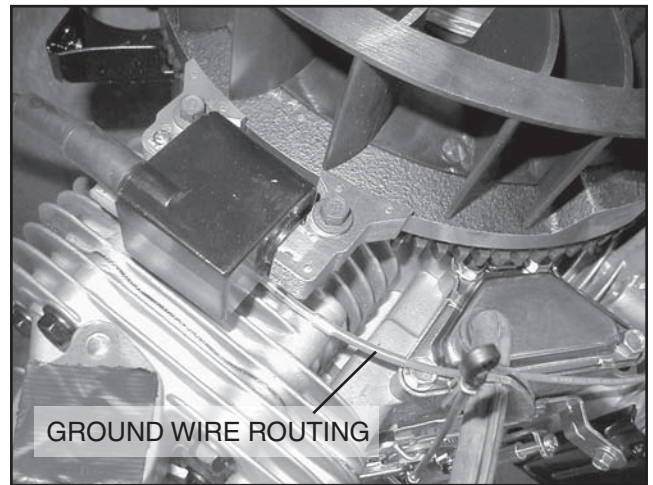


Figure 13-11. Install Coils

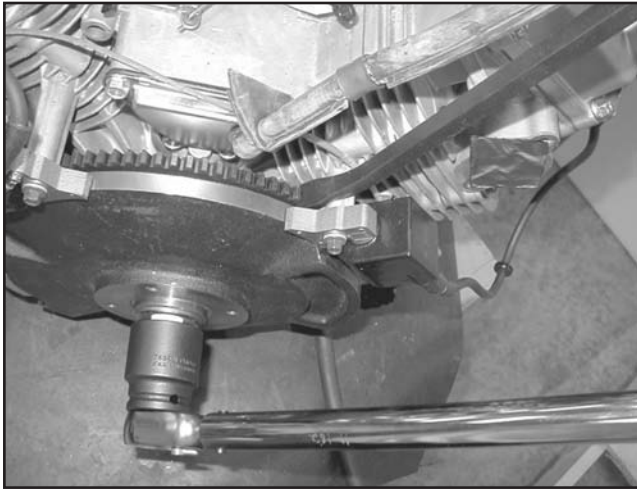
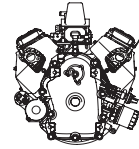
### INSTALL BREATHER

1. Insert breather material.
2. Install breather assembly and gasket.
3. Torque bolts to 4.75 Nm (40 in. lbs.).

### INSTALL FLYWHEEL

**Important:** Clean flywheel and crankshaft taper removing all oil, dirt or grease.

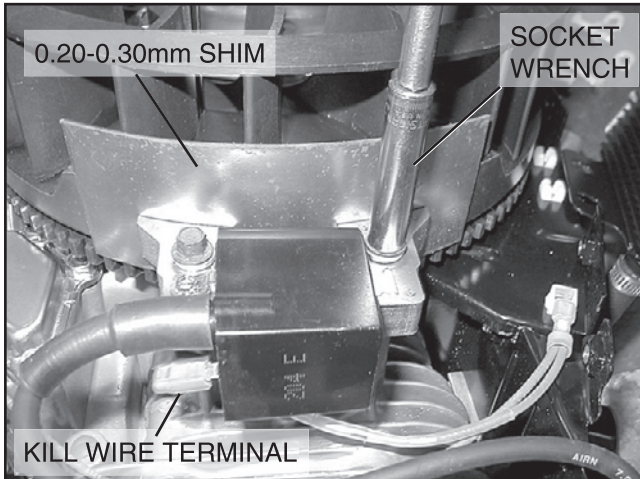
1. Insert flywheel key into crankshaft.
2. Assemble flywheel to crankshaft.
3. Install washer and flywheel nut.
4. Torque flywheel nut to 214 Nm (150 ft. lbs.), Figure 13-12.



**Figure 13-12. Torque Flywheel Nut**

### ADJUST IGNITION COIL AIR GAP

1. Rotate flywheel until magnet is under coil laminations.
2. Place 0.20-.30mm (.008"-.012") thickness, non-magnetic gauge between magnet and coil laminations, Figure 13-13.



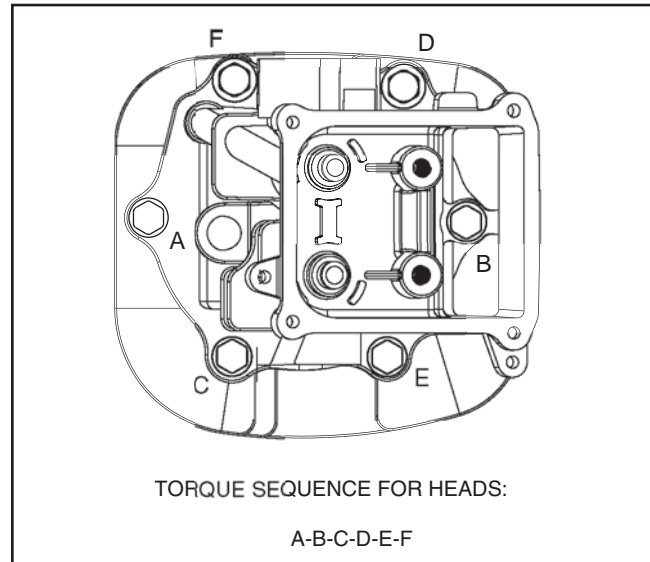
**Figure 13-13. Adjust Air Gap**

3. Loosen mounting screw so magnet will pull coil down against thickness gauge.
  - a. Torque screws to 4.75 Nm (40 in. lbs.).
4. Rotate flywheel to remove thickness gauge.
5. Repeat for second coil.

### INSTALL CYLINDER HEADS

1. Install cylinder head with new gasket.
2. Lubricate threads of head bolts with one drop of oil.

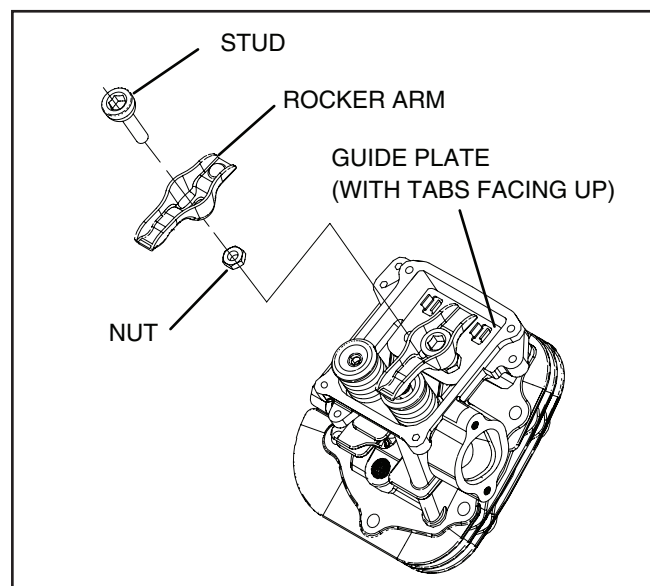
- a. Torque head bolts in sequence shown (Figure 13-14) to 29.9 Nm (22 ft. lbs.).
3. Insert push rods into recess in tappets.



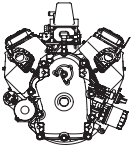
**Figure 13-14. Install Cylinder Head**

### INSTALL ROCKER ARMS

1. Lubricate rocker arms and ball studs with clean engine oil.
2. Assemble ball studs, rocker arms, jam nuts and guide plates (with tabs facing up) to cylinder head, Figure 13-15.
  - a. Make sure that the push rods are in the proper location on the tappets and the rocker arms.



**Figure 13-15. Install Rocker Arms**



**ADJUST VALVE CLEARANCE**

1. Set No. 1 cylinder at TDC (Top Dead Center), compression stroke.
  - a. Adjust rocker arms and check clearance, Figure 13-16.

**Valve Clearance (cold) INTAKE and EXHAUST 0.076mm (.003")**

- b. Torque ball studs and jam nuts to 19 Nm (168 in. lbs.).
2. Repeat for No. 2 cylinder.
3. Install valve covers with new gaskets, Figure 13-17
  - a. Torque bolts to 6.8 Nm (60 in. lbs.).

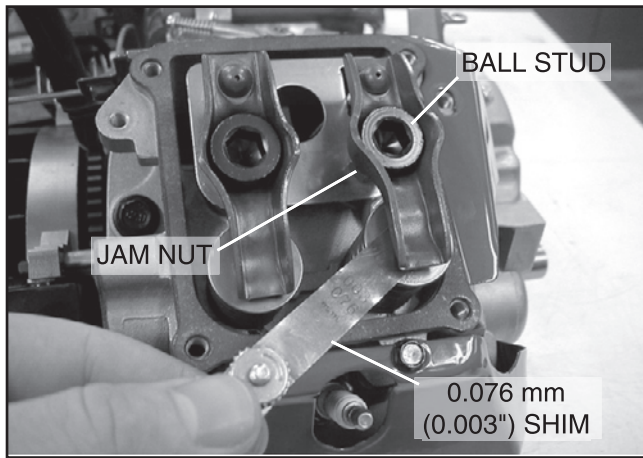


Figure 13-16. Adjust Valve Clearance

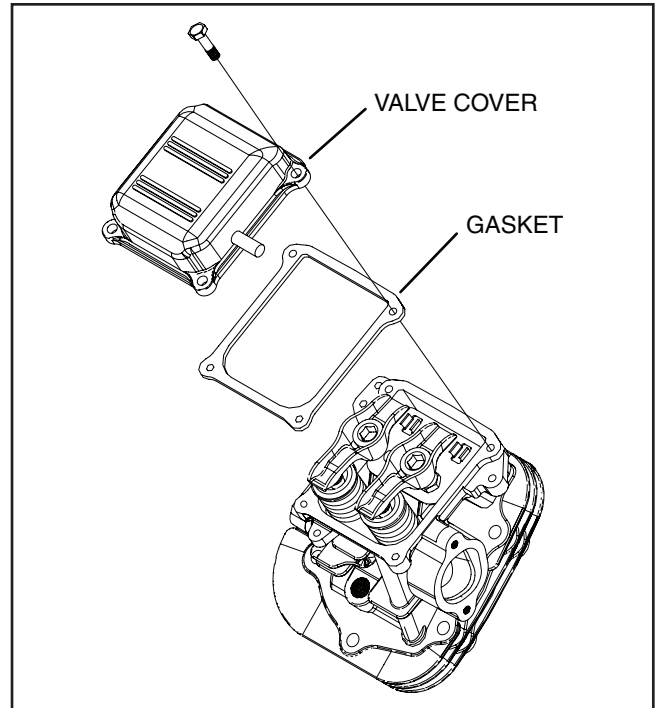


Figure 13-17. Install Valve Covers and Gaskets

**GENERAL ASSEMBLY**

1. Install cylinder shields (wrappers).
  - a. Torque M5 screws to 2.8 Nm (25 in. lbs.).

- |   |                          |
|---|--------------------------|
| 1 | FINGER GUARD             |
| 2 | ROTATING SCREEN          |
| 3 | INTAKE MANIFOLD ASSEMBLY |
| 4 | OIL COOLER               |
| 5 | BLOWER HOUSING           |
| 6 | UPPER WRAPPER            |
| 7 | LOWER WRAPPER            |
| 8 | VALVE COVER              |

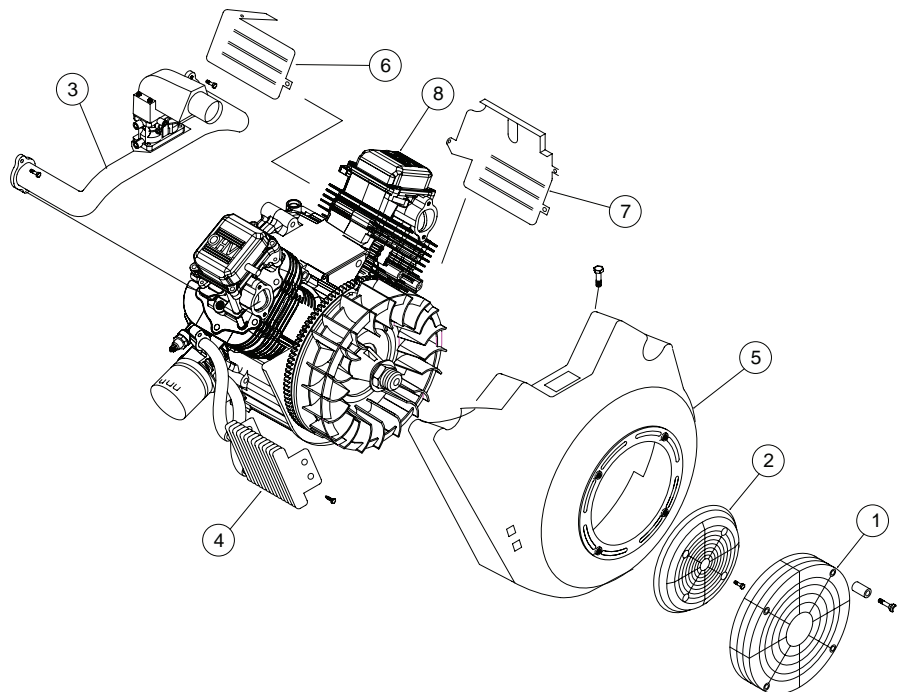
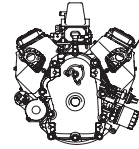
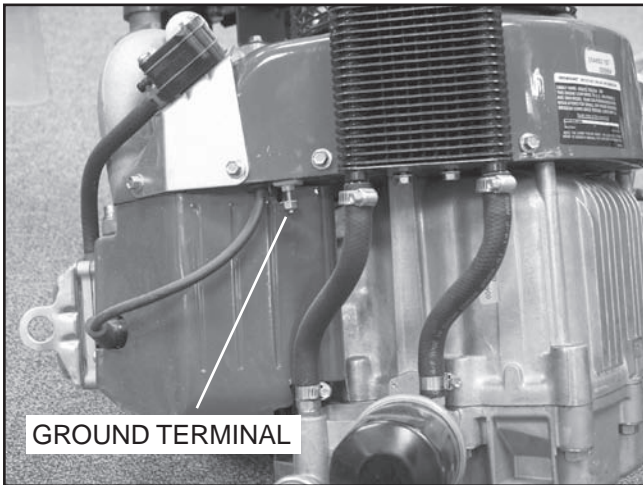


Figure 13-18. Install Blower Housing



- b. Torque M6 screws to 4.5 Nm (40 in. lbs.).
- c. Connect ignition ground wire to ignition ground terminal in backing plate (see Figure 13-19).



**Figure 13-19. Ground Terminal**

- 2. Assemble governor lever to governor arm. DO NOT tighten at this time.
- 3. Install speed adjust assembly (refer to Section 4).
  - a. Torque screws to 6.0 Nm (53 in. lbs.).
- 4. Install exhaust.
  - a. Torque screws to 19 Nm (168 in. lbs.).

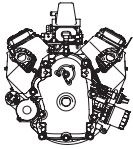
- 5. Install fan and retaining ring.
  - a. Torque screws to 21.7 Nm (192 in. lbs.).
- 6. Install blower housing.
  - a. Torque screws to 4.5 Nm (40 in. lbs.).
- 7. Install rotating screen.
  - a. Torque screws to 1.9 Nm (17 in. lbs.).
- 8. Install intake manifold assembly.
  - a. Torque bolts to 19 Nm (168 in. lbs.).
- 9. Install finger guard.
  - a. If engine is equipped with hex head screws, torque screws to 4.5 Nm (40 in. lbs).
  - b. If engine is equipped with finger screws, tighten screws by hand to approximately 1.3 Nm (12 in. lbs.).
- 10. Connect governor linkage and speed control linkage (refer to Section 4).
- 11. Install spark plugs.
  - a. Torque spark plugs to 19 Nm (168 in. lbs.).

**ADJUST GOVERNOR**

**Note: Refer to Section 4, Page 4-3 for Static Governor Adjustment.**



**WARNING: BEFORE STARTING OR RUNNING ENGINE, static adjustment of the governor must be completed! Failure to make the static adjustments first could result in engine overspeeding which may result in engine damage, property damage or personal injury.**



**GENERAL SPECIFICATIONS**

MODEL	GTH & GTV 760	GTH & GTV 990
Bore	90 mm (3.54")	90.00 mm (3.54")
Stroke	60 mm (2.36")	78 mm (3.07")
Displacement	763cc	992cc

OIL CAPACITY	GTV 760 & 990	GTH 990 & 760
With Oil Filter*	2.3L (2.4 qt)	2.2L (2.3 qt)
Without Oil Filter*	2.0L (2.1 qt)	1.9L (2.0 qt)

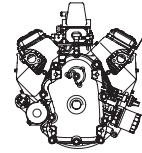
\* To prevent over filling of the crankcase, add approximately 3/4 of the total volume when refilling and then add as needed to bring the level up the the full mark.

**COMMON SPECIFICATIONS**

Ignition coil Air Gap	.008" – .012" (0.20 – 0.30 mm)
Crankshaft End Play	.002" – .015" (0.05 – 0.40 mm)
Spark Plug Gap	.040" (1.01 mm)
Valve Clearance (Cold)	
– Intake	.002" – .004" (0.05 – 0.1 mm)
– Exhaust	.002" – .004" (0.05 – 0.1 mm)
Normal Compression	
– GTH/GTV-760	130-160 psi
– GTH/GTV-990	160-190 psi

**TORQUE SPECIFICATIONS**

Alternator (to cylinder) Screws	4.75 Nm (40 in. lbs.)
Ignition Coil Screws	4.75 Nm (40 in. lbs.)
Carburetor / Plenum Mounting Bolts	5.4 Nm (48 in. lbs.)
Connecting Rod Bolts	24.4 Nm (216 in. lbs.)
Crankcase Cover Bolts	47.5 Nm (35 ft. lbs.)
Cylinder Head Bolts	29.9 Nm (22 ft. lbs.)
Exhaust Manifold Bolts	19 Nm (168 in. lbs.)
Flywheel Nut	214 Nm (150 ft. lbs.)
Flywheel Fan Retainer Bolts	21.7 Nm (182 in. lbs.)
Governor Lever (clinching screw)	11.3 Nm (100 in. lbs.)
Intake Manifold Screws	19 Nm (168 in. lbs.)
Oil Pump	12.2 Nm (108 in. lbs.)
Rocker Arm Jam Nut	19 Nm (168 in. lbs.)
Spark Plug	19 Nm (168 in. lbs.)
Starter Motor Bolts	27 Nm (228 in. lbs.)
Rocker Cover Screws	6.8 Nm (60 in. lbs.)
Blower Housing Screws	4.75 Nm (40 in. lbs.)



## STANDARD AND REJECT DIMENSIONS

DESCRIPTION	STANDARD DIMENSION	REJECT DIMENSION
<b>CYLINDER:</b>		
Bore	90.00 – 90.025 mm (3.543" – 3.544")	90.10 mm (3.547")
Out of Round		0.035 mm (.0015")
Main Bearing (Mag End)	38.044 – 38.099 mm (1.498" – 1.5")	38.25 mm (1.506")
Cam Bearing	20.00 – 20.03mm (.787" – .789")	20.06 mm (.790")
<b>CYLINDER HEAD:</b>		
Valve Guide	7.005 – 7.020 mm (.2758" – .2764")	7.06 mm (0.278")
Valve Stem	6.945 – 6.98 mm (.2734" – .2748")	6.9 mm (0.272")
Valve Spring Free Length	38.0 – 36.5 mm (1.49" – 1.43")	less than 36.5 mm (1.437")
<b>CRANKCASE COVER:</b>		
Main Bearing (PTO End)	42.044 – 42.099 mm (1.6553" – 1.6574")	42.25 mm (1.663")
Cam Bearing	18.0 – 18.025 mm (.7087" – .7096")	18.06 mm (.711")
<b>CRANKSHAFT:</b>		
Crankpin	38.99 – 39.01 mm (1.535" – 1.536")	38.96 mm (1.534")
Magneto Journal	38.00 – 38.012 mm (1.496" – 1.4965")	37.85 mm (1.490")
PTO Journal	42.00 – 42.012 mm (1.6535" – 1.654")	41.85 mm (1.648")
<b>CAMSHAFT:</b>		
Magneto Journal	19.959 – 19.98 mm (.7858" – .7866")	19.93 mm (.784")
PTO Journal	17.964 – 17.982 mm (.7072" – .708")	17.93 mm (.705")
Lobes	31.239 – 31.479 mm (1.2299" – 1.2393")	31.02 mm (1.221")
<b>CONNECTING ROD:</b>		
Crankpin Bearing	39.06 – 39.07 mm (1.5378" – 1.5382")	39.09 mm (1.539")
Piston Pin Bearing	20.02 – 20.03 mm (.7882" – .7886")	20.05 mm (.7894")
<b>PISTON PIN:</b>		
Diameter	19.984 – 19.995 mm (.7868" – .7872")	19.97 mm (.7862")
Out of Round		0.01 mm (.0005")
<b>PISTON PIN BEARING (PISTON):</b>		
Bore	20.00 – 20.02 mm (.7874" – .7882")	20.03 mm (.7886")
Out of Round		0.01 mm (.0005")
<b>PISTON RINGS:</b>		
End Gap – Top & Center	0.25 – 0.5 mm (.0098" – .0197")	0.75 mm (.0295")
End Gap – Oil	0.38 – 1.15 mm (.015" – .045")	1.5 mm (.059")
Ring Side Clearance – Top & Center	0.04 – 0.09 mm (.0016" – .0035")	0.10 mm (.004")
Ring Side Clearance – Oil	0.012 – 0.18 mm (.0005" – .007")	0.20 mm (.008")









**GENERAC® POWER SYSTEMS, INC.**

P. O. BOX 297  
WHITEWATER, WI 53190