

# QUIETSOURCE™

## Installation and Owner's Manual

Liquid-cooled, Prepackaged  
Standby Generators

Model Number  
004917-4

27 kW NG, 30 kW LP Vapor



This manual should  
remain with the unit.

⚠ Not intended for use in life-support applications. ⚠

— ⚠ **DANGER** ⚠ —

**DEADLY EXHAUST FUMES. OUTDOOR INSTALLATION ONLY!!**

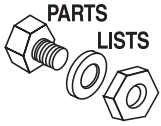

**Section 7 - Exploded Views and Parts**

**QUIETSOURCE™ Liquid-cooled 30 kW Generators  
Mounting Base – Drawing No. 0E6266-E**

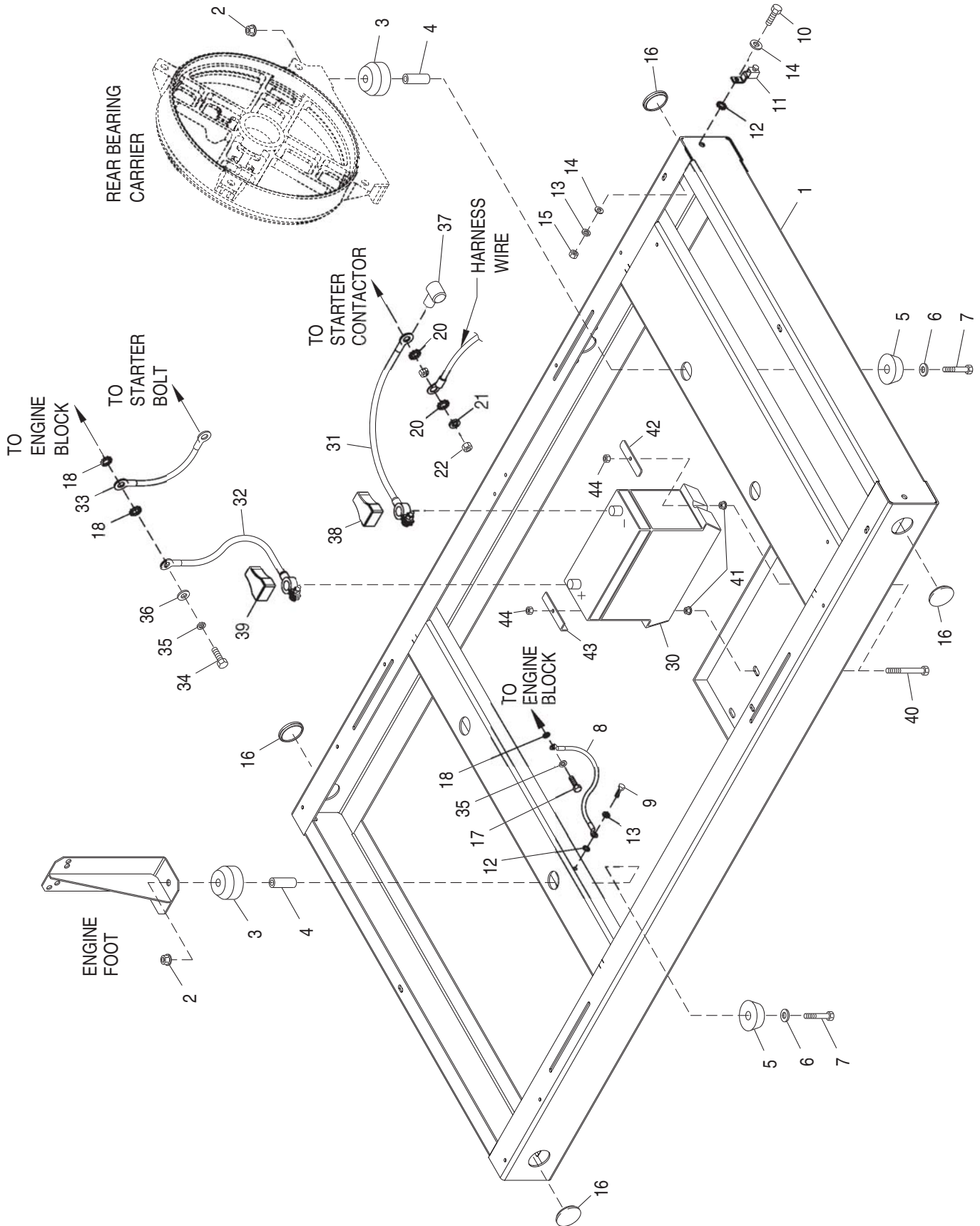

**Section 7 - Exploded Views and Parts**  
**QUIETSOURCE™ Liquid-cooled 30 kW Generators**  
**Mounting Base – Drawing No. 0E6266-E**

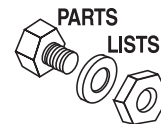

ITEM	PART NO.	QTY.	DESCRIPTION
1	0E5822	1	BASEFRAME, WELDMENT 3.0L FORD
2	052860	4	NUT FLANGED HEX M12-1.75
3	052251	4	DAMPENER VIBRATION 40 BLUE
4	052257	4	SPACER .49 X .62 X 1.87 PWDR/ZNC
5	052252	4	DAMPENER VIBRATION
6	052259	4	WASHER FLAT M12
7	052891	4	SCREW HHC M12-1.75 X 80 G8.8
8	0536210213	1	ASSY GRNDWIRE 11"/3/8 & 5/16 LUG
9	074906	1	SCREW HHTT M6-1.0 X 20 BP
10	047411	1	SCREW HHC M6-1.0 X 16 BP
11	055414	1	LUG SLDLSS #2-#8 X 17/64 CU
12	026850	2	WASHER SHAKEPROOF EXT 1/4 STL
13	022097	1	WASHER LOCK M6-1/4
14	022473	2	WASHER FLAT M6-1/4 ZINC
15	049813	1	NUT HEX M6 -1.0 G8 YEL CHR
16	0A1694	4	1-1/2" BUTTON PLUG
17	052213	1	SCREW HHC M10-1.25 X 20 G8.8
18	025507	3	WASHER SHAKEPROOF EXT 7/16 STL
20	027482	2	WASHER SHAKEPROOF EXT 5/16 STL
21	022129	1	WASHER LOCK M8-5/16
22	045771	1	NUT HEX M8-1.25 G8 YEL CHR
23 *	051756	1	SCREW HHC M10-1.5 X 20 G8.8
24 *	046526	1	WASHER LOCK M10
25 *	022131	1	WASHER FLAT 3/8-M10 ZINC
26 *	055934M	1	CLAMP VINYL .75 X .343 Z
30	077483	REF.	BATT 12VDC 75-AH 26
	058665	REF.	BATT 12VDC 90-AH 27F
31	038804D	1	CABLE BATT RED #4 X 20.00
32	038805AA	1	CABLE BATT BLK #4 X 30"
33	021991	1	EARTH STRAP
34	049814	1	SCREW HHC M10-1.5 X 25 G8.8
35	046526	2	WASHER LOCK M10
36	022131	1	WASHER FLAT 3/8 ZINC
37	075763	1	BOOT BATTERY CABLE
38	050331	1	BATTERY POST COVER BACLK -
39	050331A	1	BATTERY POST COVER RED +
40	0A4010	2	SCREW HHC M8-1.25 X 60 G8.8 FT
41	052858	2	NUT TOP LOCK FL M8-1.25
42	061902	1	HOLD DOWN BATTERY
43	059473	1	HOLD DOWN BATTERY
44	049820	2	NUT HEX LOCK M8-1.25 NY INS

\* NOT SHOWN-USED TO HOLD DOWN I/N 32



**Section 7 - Exploded Views and Parts**

**QUIETSOURCE™ Liquid-cooled 30 kW Generators  
Compartment – Drawing No. 0F1141-A**

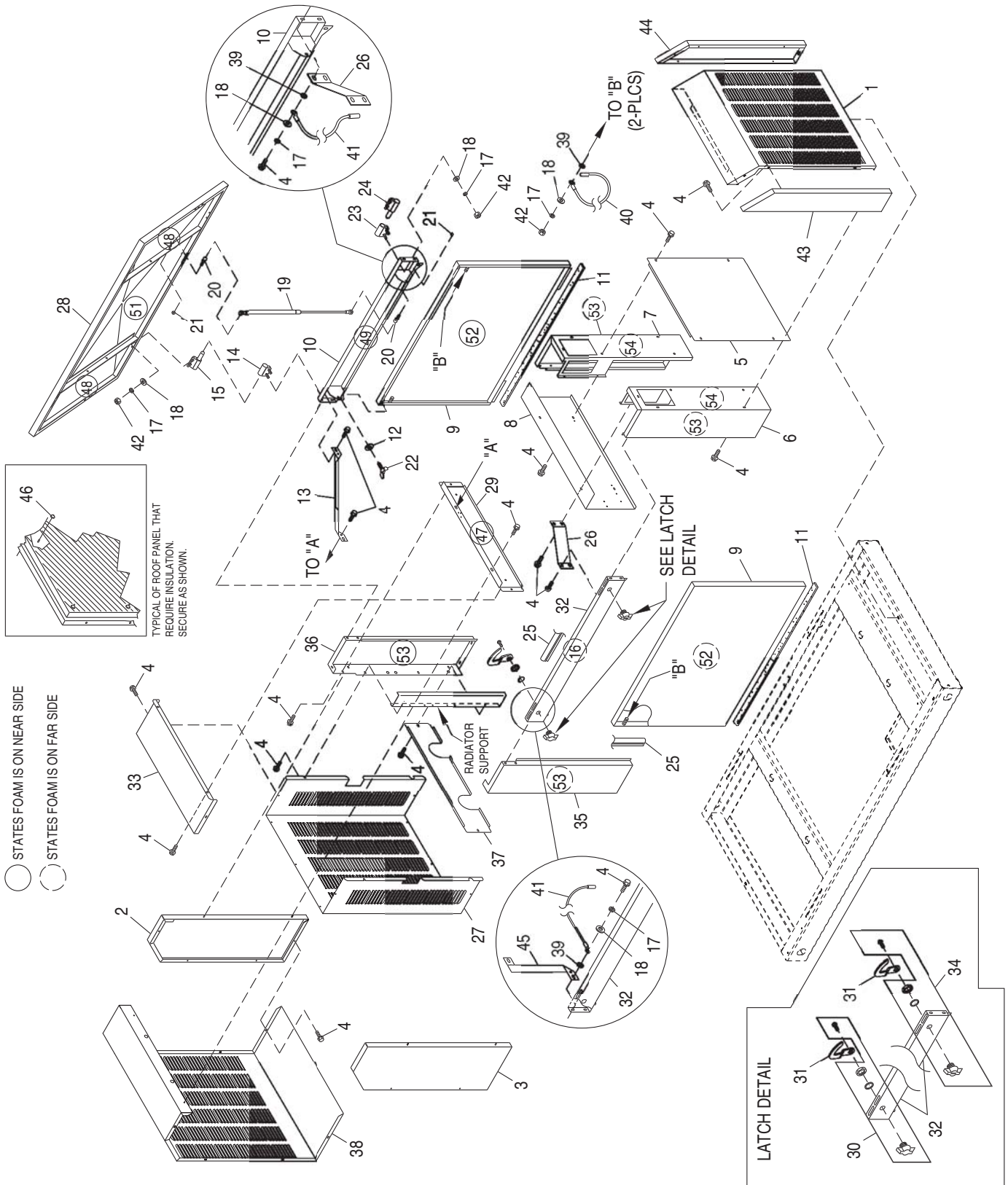

**Section 7 - Exploded Views and Parts**  
**QUIETSOURCE™ Liquid-cooled 30 kW Generators**  
**Compartment – Drawing No. 0F1141-A**

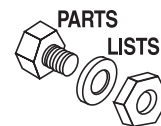

ITEM	PART NO.	QTY.	DESCRIPTION
1	0E8418	1	DUCT INTAKE MID AL
2	0E8414	1	DUCT DISCHARGE RH AL
3	0E8413	1	DUCT DISCHARGE LH AL
4	0C2454	62	SCREW TH-FRM M6-1 X 16 N WA Z/JS
5	0E8402	1	BAFFLE REAR BOTTOM
6	0E5902	1	POST CORNER LH REAR HSB AL
7	0E5903	1	POST CORNER RH REAR HSB AL
8	0E8387	1	BAFFLE REAR TOP
9	0E5912	2	DOOR SIDE HSB AL
10	0F5570	1	SUPPORT RH SIDE HSB AL
11	089961	2	FOAM STRIP 3/4" WIDE X 3/16" THK (40" LG)
12	0A2115	4	WASHER NYLON .257
13	0E8404	1	BRACKET STIFFENER RH FRONT
14	0F0165A	1	HINGE TYPE B W/STUDS, SOCKET
15	0F0165	1	HINGE TYPE B W/STUDS, PIN
16	0E7829S	1	AI SUPPORT LH PANEL
17	022097	12	WASHER LOCK M6-1/4
18	022473	12	WASHER FLAT 1/4-M6 ZINC
19	0E7570	2	GAS SPRING
20	0E7571	4	BALL STUD GAS SPRING MOUNT
21	070015	4	NUT HEX 5/16-18 LOCK
22	0E7662	4	SCREW WING M6-1.00 X 25
23	0F0164A	1	HINGE TYPE A W/STUDS, SOCKET
24	0F0164	1	HINGE TYPE A W/STUDS, PIN
25	0D2023	3	GASKET CLIP-ON SELF GRIPPING (84" LG)
26	0E7869	2	BRACKET STIFFENING BACK
27	0E8001	1	MUFFLER BOX
28	0F5568	1	ROOF HSB AL ACOUSTIC
29	0E5915	1	BRACE FRONT TOP HSB AL
30	0D3037A	1	LATCH 1/4 TURN NONLOCKING
31	0C7781	2	PAWL DOOR HSB
32	0E5910	1	SUPPORT LH SIDE HSB AL
33	0E8052	1	MUFFLER BOX TOP
34	0D3037	1	LATCH QUARTER TURN LOCKING
35	0E5900	1	POST CORNER LH FRONT HSB AL
36	0E5901	1	POST CORNER RH FRONT HSB AL
37	0F1131	1	BRACE, FRONT BOT 3.0L FD ALUM
38	0E8415	1	DUCT DISCHARGE MID AL
39	026850	4	WASHER SHAKEPROOF EXT 1/4 STL
40	0912970063	2	ASSY GRD WIRE 99HSB
41	0912970064	2	ASSEMBLY,BASE-DOOR GROUND WIRE
42	049813	10	NUT HEX M6 X 1.0 G8 YEL CHR
43	0E8416	1	DUCT INTAKE LH AL
44	0E8417	1	DUCT INTAKE RH AL
45	0E8665	1	BRACKET STIFFENER LH FRONT
46	078115	8	WASHER SELF LOCKING DOME
47	0E7829U	2	AI BRACE PANEL
48	0E7829N	2	AI ROOF PANEL 2
49	0E7829T	1	AI SUPPORT RH PANEL
50 *	0E8441	1	KIT INSULATION 3.0L HSB
51	0E7829A	1	AI ROOF PANEL 1
52	0E7829B	2	AI DOOR PANEL
53	0E7829P	4	AI CORNER POST PANEL 1
54	0E7829R	2	AI CORNER POST PANEL 2

\* ALL ITEMS NOTATED WITH "AI" ARE COMPONENTS OF 0E8441

**Section 7 - Exploded Views and Parts**  
**QUIETSOURCE™ Liquid-cooled 30 kW Generators**  
**Control Panel – Drawing No. 0E7118-J**

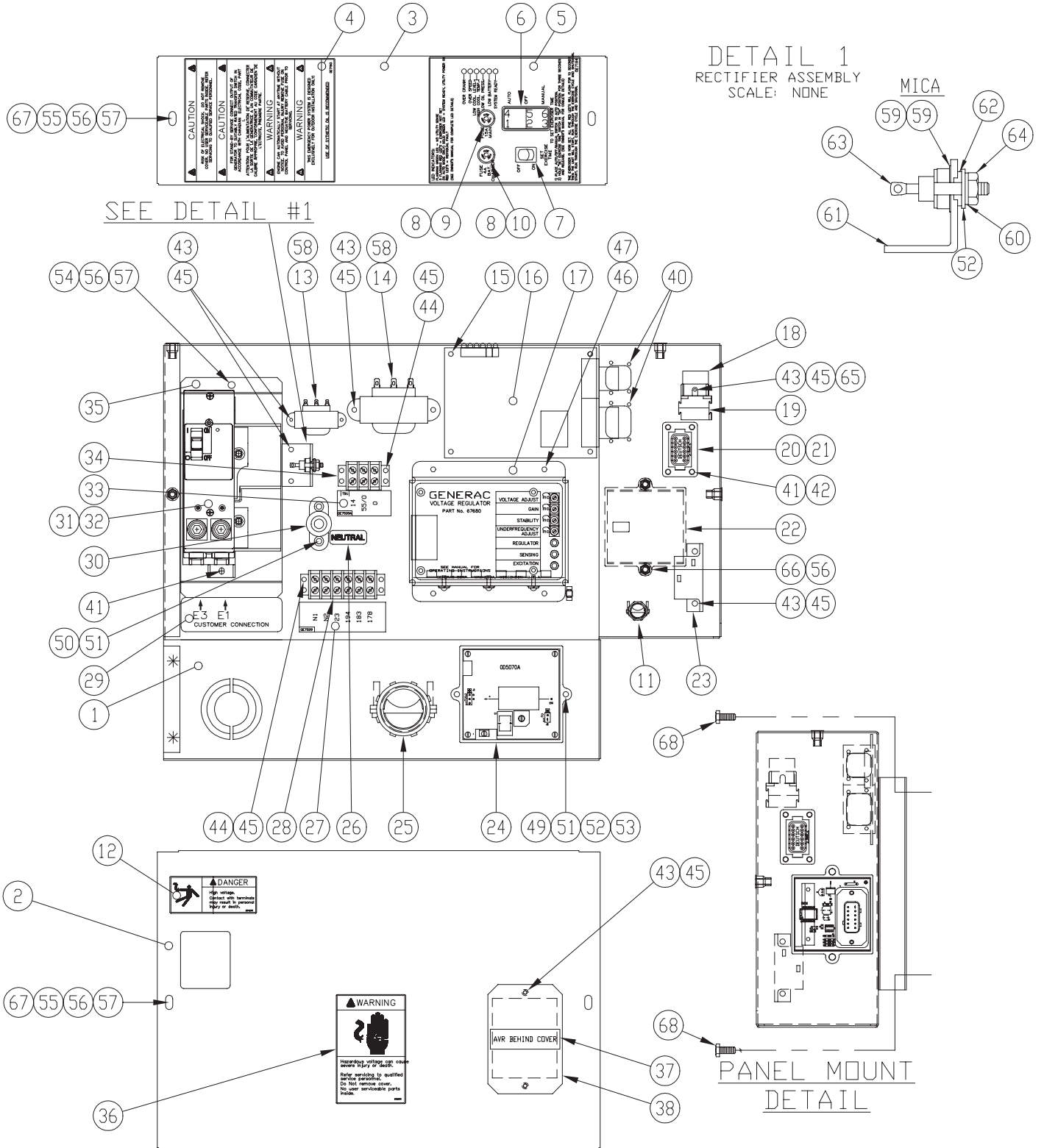

Section 7 - Exploded Views and Parts

QUIETSOURCE™ Liquid-cooled 30 kW Generators  
Control Panel – Drawing No. 0E7118-J

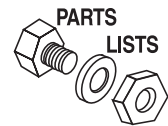

ITEM	PART NO.	QTY.	DESCRIPTION	ITEM	PART NO.	QTY.	DESCRIPTION
1	0E7195	1	CONTROL BOX HSB	36	0C1229	1	DECAL WARNING ELECTRICAL SHOCK
2	0E7196	1	COVER FRONT PANEL HSB	37	0C1127	1	DECAL AVR COVER
3	0E7197	1	COVER TOP PANEL HSB	38	0A1441B	1	COVER PLATE, AVR
4	0E7193	1	DECAL WARNINGS HSB	39	0E7128	1	HARNESS CNTRL PNL (NOT SHOWN)
5	0E7194	1	DECAL CONTROLS HSB	40	0E7358	8	SCREW PPPH HI-LO #4-24 X 3/8
6	0E4494	1	SWITCH ROC DPDT ON-OFF-ON	41	074908	6	SCREW HHTT M5-0.8 X 10 BP
7	082573	1	SWITCH ROCKER DPST 125V SPD	42	0C5141	1	CONN DEUTSCH GASKET 8/12 POS DT
8	032300	2	HOLDER FUSE	43	0C2699	11	SCREW PHTT #6-32 X 3/8 ZYC
9	022676	1	FUSE 15A X AGC15	44	0C2323	4	SCREW PHTT #6-32 X 5/8 ZYC
10	067682B	1	FUSE 4A SLO BLO GLASS	45	022155	15	WASHER LOCK #6
11	060015	1	FITTING CONDUIT 90D 3/8"	46	0C2265	4	SCREW PHTT M4-0.7 X 12 ZYC
12	054199	1	DECAL DANGER HIGH VOLTAGE	47	022264	4	WASHER LOCK #8-M4
13	0C2657	1	TRANSFRMR 16V 6VA	49	020911	2	SCREW PPHM M5-0.8 X 30 ZINC
14	099076	1	TRANSFORMER 16V 56VA	50	066849	2	SCREW HHTT M5-0.8 X 16
15	040213	2	PCB SUPPORT SNAP-IN 1/4"	51	022152	4	WASHER LOCK #10
16	0E9668	1	ASSY PCB HSB CONTROLLER 3.9L	52	023897	3	WASHER FLAT #10 ZINC
	0E4905	1	ASSY PCB HSB CONTRLR 3.0L FORD	53	051716	2	NUT HEX M5-0.8 G8 YEL CHR
17	067680	1	ASSY VOLTAGE REGULATOR 60HZ	54	090388	2	SCREW HHTT M6-1.0 X 12 ZINC
18	0E6875A	1	RELAY 12VDC C FORM W/DIODE	55	042568	4	SCREW HHC M6-1.0 X 20 G8.8
19	0E6881 *	REF.	SOCKET RELAY	56	022097	8	WASHER LOCK M6-1/4
20	0C5139 *	REF.	CONN DEUTSCH RECEPT GY/FLN	57	022473	6	WASHER FLAT 1/4-M6 ZINC
21	0C5142 *	REF.	CONN DEUTSCH RECEPT WDGE BLKHD	58	0441140187	2	WIRE ASSY 3" X (2) 3/16" TABS
22	0E3161	1	ASSY BOSCH GOV DRIVER	59	070370	2	WASHER MICA .203
23	054450	1	CIRCT BRK 5.5 X 1 ETA 46-500-P	60	023762	1	WASHER SHAKEPROOF EXT #10 STL
24	0D5070A	1	ASSY 2A 12V UL BATTERY CHARGER	61	055444	1	HEATSINK
25	0E2514	1	FITTING CONDUIT STR 1-1/2"	62	030468	1	WASHER STEP NYLON .20
26	0A9457	1	DECAL NEUTRAL	63	049939	1	RECTIFIER MSC 12A 600V 1N1206R
27	0E7539	1	DECALCUSTOMER CNNCTN XFER SW	64	022158	1	NUT HEX #10-32 STEEL
28	046357 *	REF.	BLOCK TERM 20A 6 X 6 X 1100V	65	022985	1	WASHER FLAT #6 ZINC
29	0D3719B	1	DECAL CUSTOMER CNNCTN	66	038750	2	SCREW HHC M6-1.0 X 30 G8.8
30	057073	1	JUNCTION BLOCK 3/8-16	67	0A2115	4	WASHER NYLON .257
31	0E7283	1	CB 0150A2P240V S QN2 LL	68	0C2454	4	SCREW THF M6-1 X 16 N WA Z/JS
	0E3628	1	CB 0200A2P240V S QN2 LL	69	0F6146	1	HANG TAG 2 WIRE START (NOT SHOWN)
32	0E3664	1	BASE QN CIRCUIT BREAKER				
33	0E7539A	1	DECAL TB1 HSB CONTROL PANEL				
34	0D4698 *	REF.	BLOCK TERM 20A 6 X 3 X 1100V				
35	0E7252	1	BRACKET CB 221.5 X 102				

\* ITEMS INCLUDED AS PART OF I/N 39





**Section 7 - Exploded Views and Parts**

**QUIETSOURCE™ Liquid-cooled 30 kW Generators**

**Engine – Drawing No. 0E8170-N**

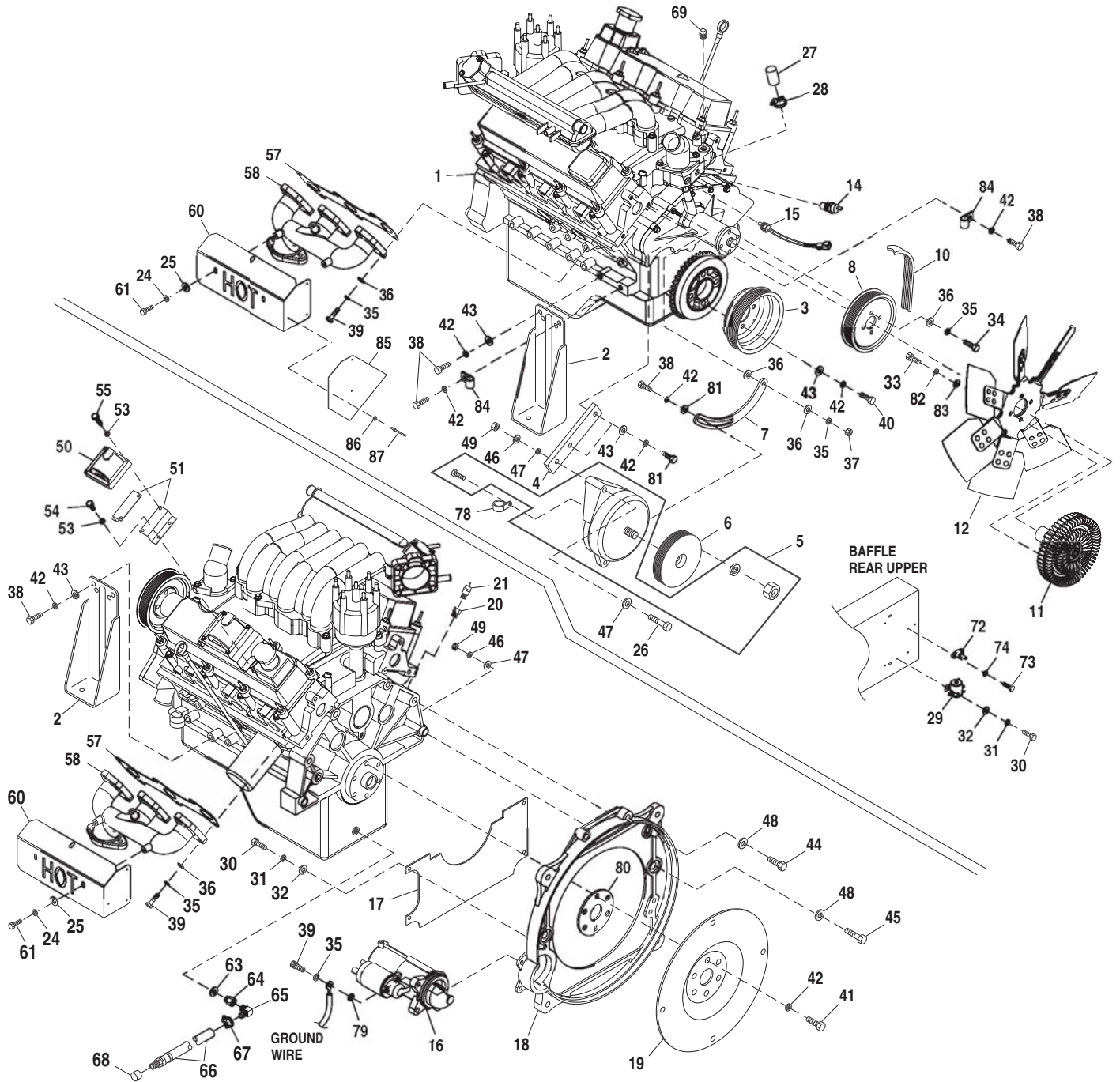



**Section 7 - Exploded Views and Parts**  
**QUIETSOURCE™ Liquid-cooled 30 kW Generators**  
**Engine – Drawing No. 0E8170-N**

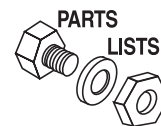

ITEM	PART NO.	QTY.	DESCRIPTION	ITEM	PART NO.	QTY.	DESCRIPTION
1	0E6202	1	ENGINE 3.0L FORD (RD) (MAKE)	47	049808	2	WASHER FLAT M12
2	0E8824	2	STAMPING ENG FOOT 3.0L FORD	48	051430	6	WASHER SHAKEPROOF INT 1/2
3	0E8963	1	PULLEY CRANKSHAFT 3.0L FORD RD	49	045773	3	NUT HEX M12-1.75 G8 YEL CHR
4	0E9020	1	BRACKET DC ALT 3.0L FORD	50	0E6203C	1	COIL IGNITION 3.0L FORD
5	0A1232	1	D.C. ALTERNATOR ASSY	51	0E6679	2	BRACKET IGN COIL 3.0L FORD
6	0A7801B	1	PULLEY POLY-V 82 OD.	53	049226	7	WASHER LOCK M5
7	0A5610	1	BRACKET ALTERNATOR	54	091526	3	SCREW PPHM M5-0.8 X 12 ZNC
8	0E6308	1	PULLEY WATERPUMP 3.0L FORD (RD)	55	093278	4	SCREW HHTT M5-0.8 X 25 BP
9 **	0E7804	1	HARN IGNITION 3.0L FORD (NOT SHOWN)	56	0E6517	1	HARNES ENGINE 3.0L FORD HSB (NOT SHOWN)
10	0D3488F	1	BELT SERPENTINE 38.35	57	0E7163	2	GASKET EXHAUST 3.0L FORD
11	0E7996	1	CLUTCH COOLING FAN FORD	58	0E5527	2	MANIFOLD EXHAUST 3.0L FORD
12	0E8006	1	FAN 18" 7 BLADE STEEL ECS	60	0E7202	2	HEAT SHIELD 260 X 80 HOT
14	035606	1	SENSOR HI COOLANT SHUTDOWN	61	085296	6	SCREW HHC 1/4-20 X 1/2 SS
15	0E0561	1	ASSY WATER LEVEL SENSOR C/E PL	62	0E6203D	1	WIRE SET 3.0L FORD (NOT SHOWN)
16	0E6729	1	STARTER DELCO-REMY 12V	63	057772	1	WASHER NYLON .565
17	0E6703	1	COVER FLYWHEEL ACCESS 3.0L HSB	64	057765	1	ADAPTER M14-1.50 X 3/8 NPT
18	0E6667	1	ENGINE ADAPTER 3L FORD	65	043790	1	BARBED EL 90 3/8 NPT X 3/8
19	0E5048	1	FLEXPLATE 3.0L FORD	66	069860C	1	HOSE OIL DRAIN ASSY 21"
20	035579	1	BUSHING REDUCER 1/4 TO 1/8	67	057822	2	CLAMP HOSE #8 .53-1.00
21	0A8584	1	SWITCH OIL PRESSURE 10PSI 2POL	68	069811	1	CAP HEX 1/4 NPT BRASS
24	083896	6	WASHER LOCK 1/4-M6 SS	69	026925	1	PLUG STD PIPE 3/8 STEEL SQ HD
25	084929	6	WASHER FLAT 1/4 SS	70 *	065852	1	SPRING CLIP HOLDER .37-.62
26	055597	1	SCREW HHC M12-1.75 X 85 G8.8	71 *	0A2111	1	SCREW SWAGE 10-32 X 5/16 Z/YC
27	077996	1	CAP HOSE	72	057073	1	JUNCTION BLOCK 3/8-16
28	057823	1	CLAMP HOSE #10 .56-1.06	73	066849	2	SCREW HHTT M5-0.8 X 16
29	056739	1	RELAY SOLENOID 12VDC PNL MNT	74	022152	2	WASHER LOCK #10
30	047411	6	SCREW HHC M6-1.0 X 16 G8.8	75	0E7880	2	CLIP SPARK PLUG 3P SCREW-MOUNT (NOT SHOWN)
31	022097	6	WASHER LOCK M6-1/4	76	0E7880A	4	CLIP SPARK PLUG 2P SCREW-MOUNT (NOT SHOWN)
32	022473	6	WASHER FLAT 1/4-M6 ZINC	77	0E7880B	1	CLIP SPARK PLUG 3P FREEHANG (NOT SHOWN)
33	047411	4	SCREW HHC M6-1.0 X 16 G8.8	78	055934C	1	CLAMP VINYL .5 X .406 Z
34	040976	4	SCREW SHC M8-1.25 X 20 G12.9	79	027482	1	WASHER SHAKEPROOF EXT 5/16 STL
35	022129	24	WASHER LOCK M8-5/16	80	0E8940	1	SPACER FLEXPLATE HSB
36	022145	22	WASHER FLAT 5/16-M8 ZINC	81	0A7387	2	SCREW HHC M10-1.5 X 40 G10.9
37	045771	1	NUT HEX M8-1.25 G8 YEL CHR	82	022097	4	WASHER LOCK M6-1/4
38	051756	6	SCREW HHC M10-1.5 X 20 G8.8	83	022473	4	WASHER FLAT 1/4-M6 ZINC
39	049821	16	SCREW SHC M8-1.25 X 30 G12.9	84	055934H	2	CLAMP VINYL .62 X .406 Z
40	059980	4	SCREW HHC M10-1.5 X 25 G10.9	85	0F5966	1	REFLECTIVE HEAT SHIELD 3.0L FD
41	0D5417	REF.	SCREW HHC M10-1.0 X 25 G10.9	86	022985	3	WASHER FLAT #6 ZINC
42	046526	18	WASHER LOCK M10	87	036261	3	RIVET POP .125 X .275 SS
43	022131	11	WASHER FLAT 3/8-M10 ZINC				
44	059982	4	SCREW SHC M12-1.75 X 45 G10.9				
45	098780	2	SCREW HHC M12-1.75 X 65 G8.8				
46	051769	3	WASHER LOCK M12				

\* NOT SHOWN-USED TO HOLD OIL DRAIN ASSEMBLY.

\*\* NOT SHOWN

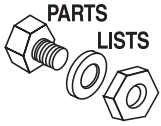

**Section 7 - Exploded Views and Parts**  
**QUIETSOURCE™ Liquid-cooled 30 kW Generators**  
**Radiator – Drawing No. 0E8528-B**

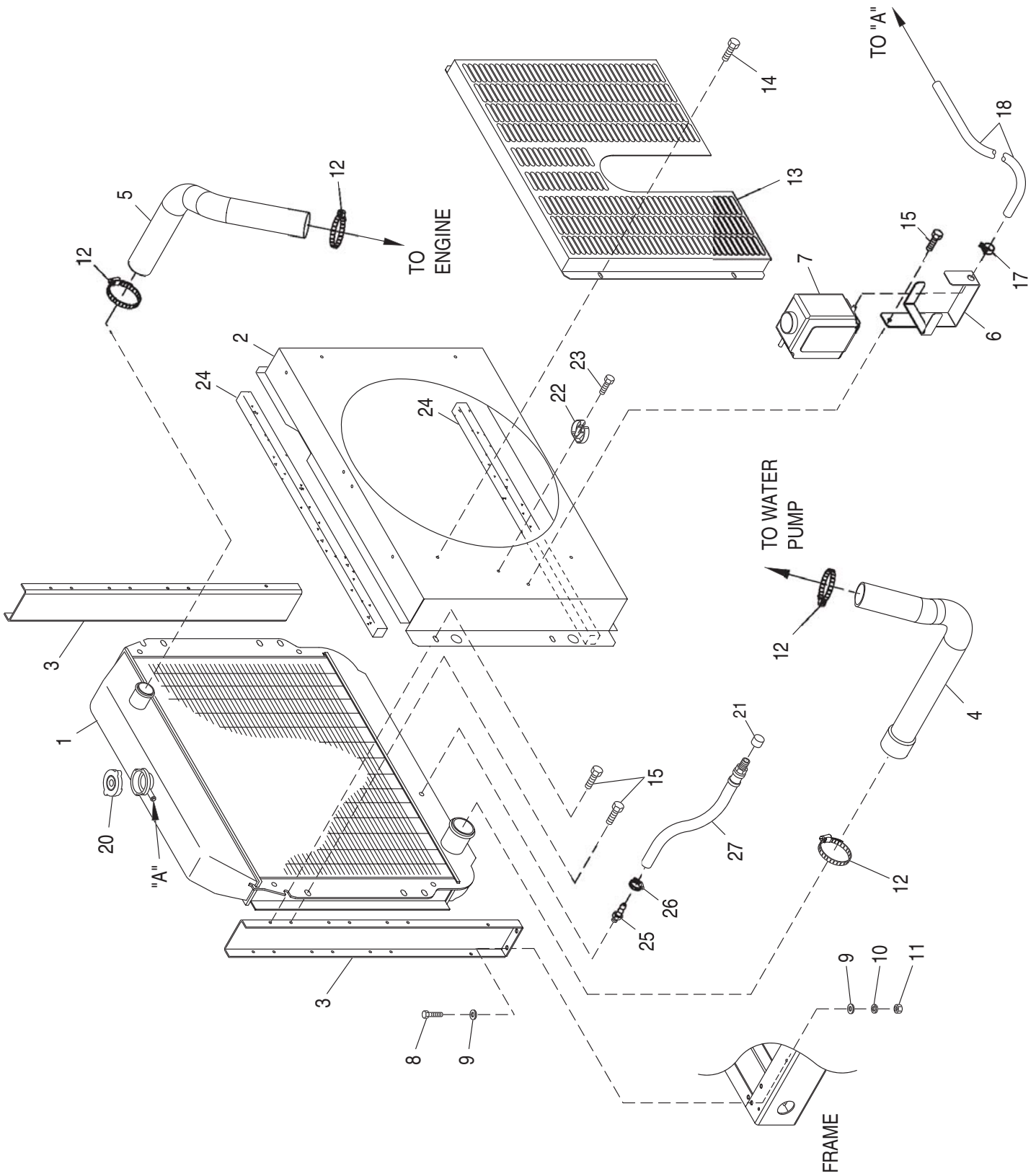

**Section 7 - Exploded Views and Parts**  
**QUIETSOURCE™ Liquid-cooled 30 kW Generators**  
**Radiator – Drawing No. 0E8528-B**

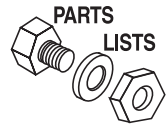

ITEM	PART NO.	QTY.	DESCRIPTION
1	0E9947	1	RADIATOR R-IN,L-OUT 658X489X49
2	0E6340	1	VENTURI 3.0L FORD HSB
3	0E8531	2	SIDE SUPPORT RADIATOR HSB
4	0E6398	1	TUBE LOWER RAD 3.0L FORD HSB
5	0E6397	1	HOSE UPPER RAD 3.0LFORD HSB
6	080713	1	BRACKET COOLANT TANK
7	076749	1	TANK COOLANT RECOVERY
8	049814	4	SCREW HHC M10-1.5 X 25 G8.8
9	022131	8	WASHER FLAT 3/8-M10 ZINC
10	046526	4	WASHER LOCK M10
11	045772	4	NUT HEX M10-1.5 G8 YEL CHR
12	035685	4	CLAMP HOSE #28 1.32-2.25
13	0E8562	1	FAN GUARD HSB
14	058443	4	SCREW CRIMPTITE 1/4-20 X 5/8
15	0C2454	9	SCREW TH-FRM M6-1 X 16 N WA Z/JS
17	048031C	1	CLAMP HOSE BAND 1/4
18	029032	1	HOSE 9/32 ID (30" LG)
20	046627	1	CAP RADIATOR
21	069811	1	CAP HEX 1/4 NPT BRASS
22	065852	1	SPRING CLIP HOLDER .37-.62
23	0A2111	1	SCREW SWAGE 10-32 X 5/16 Z/YC
24	052250	2	TAPE FOAM 1 X 1 (27" LG)
25	035461	1	BARBED STR 1/4 NPT X 3/8
26	0C7649	1	CLAMP HOSE .38-.87
27	069860C	1	HOSE OIL DRAIN ASSY 21"

Section 7 - Exploded Views and Parts  
**QUIETSOURCE™ Liquid-cooled 30 kW Generators**  
**Fuel System – Drawing No. 0E8190-C**

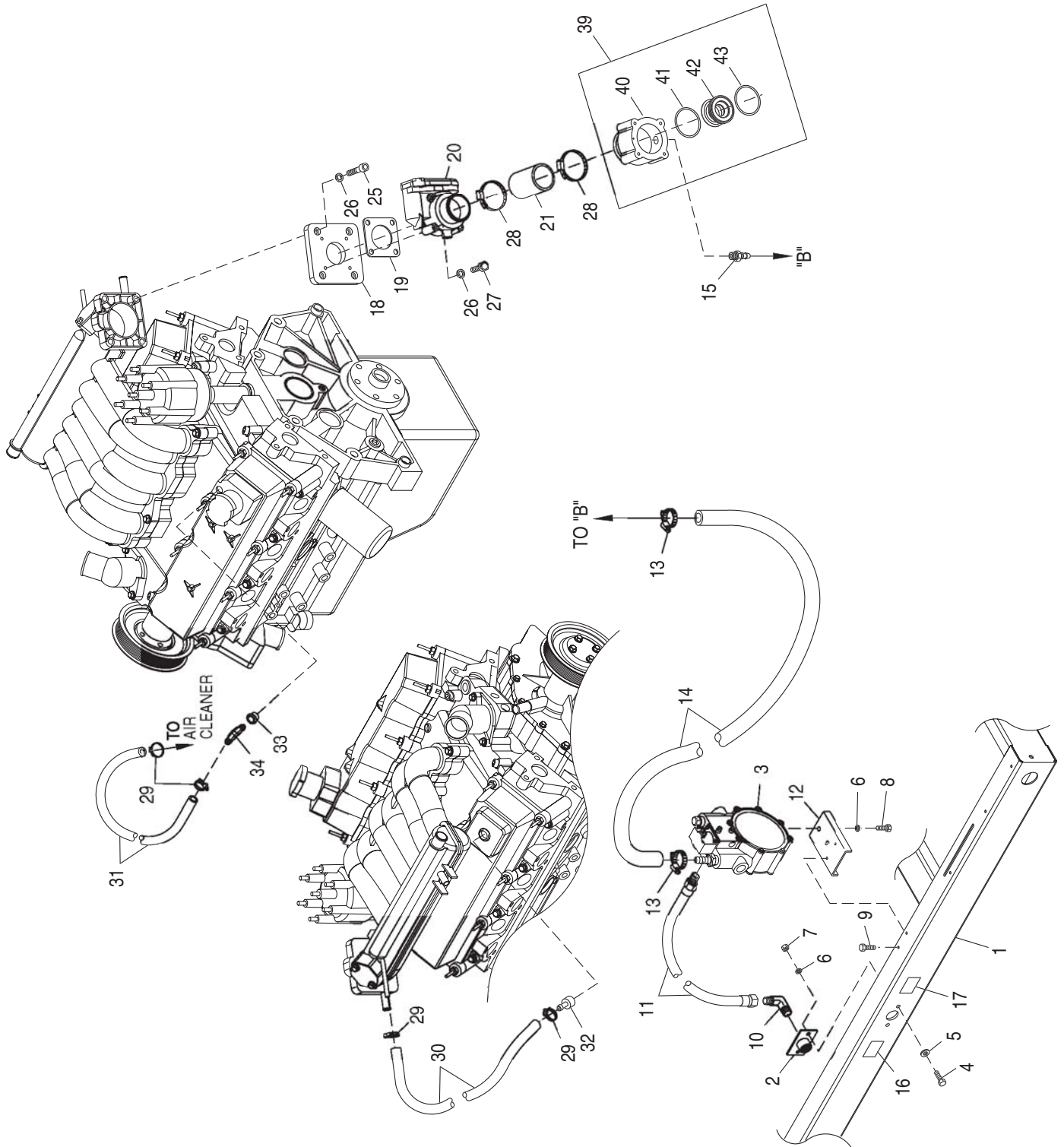

**Section 7 - Exploded Views and Parts**  
**QUIETSOURCE™ Liquid-cooled 30 kW Generators**  
**Fuel System – Drawing No. 0E8190-C**

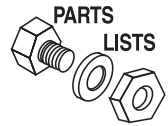

ITEM	PART NO.	QTY.	DESCRIPTION
1 *	-----	1	WELDMENT MOUNTING BASE
2	075580	1	FLANGE FUEL INLET
3	0E7691	1	ASSY REGULATOR 3.0L NG OR LPV
4	039253	2	SCREW HHC M8-1.25 X 20 G8.8
5	022145	2	WASHER FLAT 5/16 ZINC
6	022129	4	WASHER LOCK M8-5/16
7	045771	2	NUT HEX M8-1.25 G8 YEL CHR
8	042907	2	SCREW HHC M8-1.25 X 16 G8.8
9	0C2454	2	SCREW TH-FRM M6-1 X 16 N WA Z/JS
10	026307	1	ELBOW 90D STREET 3/4
11	0E1056	1	FUEL HOSE ASSY NAT.GAS/L.P.V.
12	0E6584	1	BRACKET REGULATOR 3.0L FORD HSB
13	057823	2	CLAMP HOSE #10 .56 - 1.06
14	059194	1	HOSE 5/8 ID LPG & NG (20" LG)
15	044117	1	BARBED STR 3/8 NPT X 5/8
16	0D1509	1	DECAL INLET PRESSURE
17	050279	1	DECAL FUEL INLET NG
18	0E6123	1	INTAKE ADAPTER 3.0L FORD-BOSCH
19	0E6586	1	GASKET BOSCH 32
20	0E4395	1	ACTUATOR BOSCH 32 GOVERNOR
21	057753B	1	HOSE 1.5 ID X 2 LG 20R4
25	047487	4	SCREW SHC M6-1.0 X 18 G12.9
26	022097	8	WASHER LOCK M6-1/4
27	051751	4	SCREW HHC M6-1.0 X 50 G8.8
28	035685	2	CLAMP HOSE #28 1.32-2.25
29	057823	4	CLAMP HOSE #10 .56-1.06
30	047290	1	HOSE 3/8 ID SINGLE BRAID (305mm [12"] LONG)
31	047290	1	HOSE 3/8 ID SINGLE BRAID (432mm [17"] LONG)
32	0A4121	1	VALVE PCV
33	0E6609	1	GROMMET ROCKER COVER 3.0LFORD
34	049099	1	BARBED EL 90 3/8 X 3/8 PLST
35 **	055934M	1	CLAMP VINYL .75 X .343 Z
36 **	047411	1	SCREW HHC M6-1.0 X 16 G8.8
37 **	022097	1	WASHER LOCK M6-1/4
38 **	022473	1	WASHER FLAT 1/4-M6 ZINC
39	0E9295A	1	ASSY THROTTLE 27MM
40	0E6382A	1	VENTURI HOLDER W/32MM ACTUATOR
41	0E7121	1	O-RING 47.625 ID X 2.38 WIDTH
42	0E6376A	1	VENTURI, 27 ID THROTTLE W/CHOK
43	0F2119	1	O-RING 45.63 ID X 2.62 WIDTH

\* SHOWN IN OTHER VIEW

\*\* NOT SHOWN-USED TO HOLD #31 IN PLACE

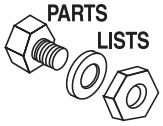

Section 7 - Exploded Views and Parts

QUIETSOURCE™ Liquid-cooled 30 kW Generators  
Alternator – Drawing No. 0F5092-A

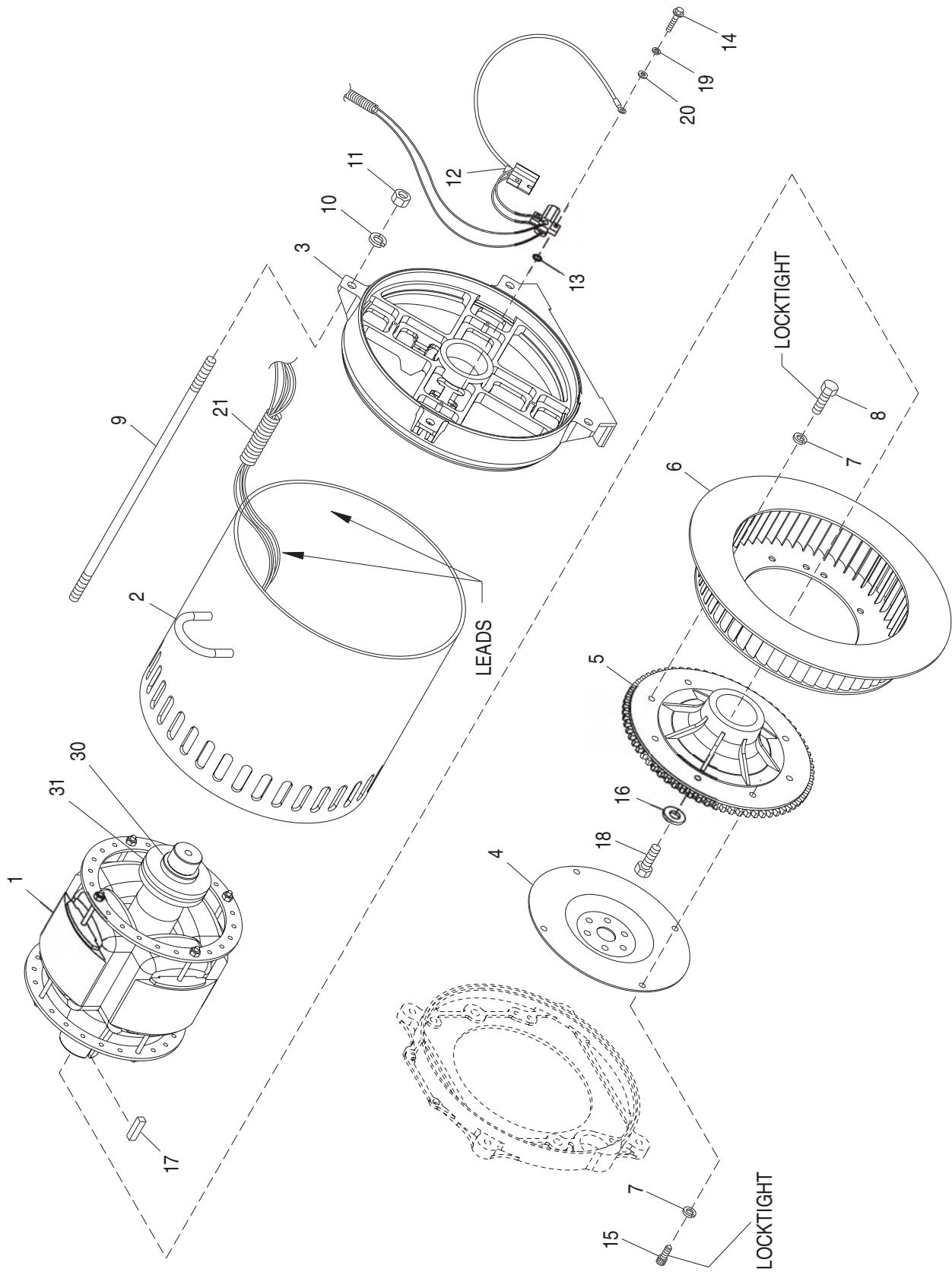



**Section 7 - Exploded Views and Parts**  
**QUIETSOURCE™ Liquid-cooled 30 kW Generators**  
**Alternator – Drawing No. 0F5092-A**

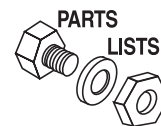

ITEM	PART NO.	QTY.	DESCRIPTION
1	0F1659A	1	ROTOR 390 15KW 1P DIRECT HSB (2.5L FORD)
	0F1657A	1	ROTOR 390 20KW 1P DIRECT HSB (2.5L FORD)
	0F1655A	1	ROTOR 390 25KW 1P DIRECT HSB (2.5L FORD)
	0F5073A	1	ROTOR 390__30AD1 HSB TECUM
	0E7413A	1	RTR 390 40KW 1P DIRECT HSB
2	0F1660A	1	STR 390 15AD HSB (382MM LONG) (2.5L FORD)
	0F1658A	1	STR 390 20AD HSB (382MM LONG) (2.5L FORD)
	0F1656A	1	STR 390 25AD HSB (382MM LONG) (2.5L FORD)
	0F5074A	1	STR-390__30AD1 HSB TECUM
	0E7412A	1	STR-390--40AD HSB (433MM LONG)
3	0E5706	1	REAR BEARING CARRIER 390/DRCT
4	0E5048	REF	FLEXPLATE 3.0L FORD
	0E5048B	REF	FLEXPLATE 2.5L FORD
	0E5048A	REF	FLEXPLATE HSB 3.9L CHRYSLER
5	0E6668	1	FLYWHEEL ASSY 3.0L HSB LG GEAR
6	0E6076	1	REVCOR FAN 10.75 X 2 W/PRESS DIS
7	046526	8	WASHER LOCK M10
8	051755	4	SCREW HHC M10-1.5 X 16 G8.8
9	04576100BK	4	STUD M14-2.0 X 490 G5 ZINC (3.0L FORD & 2.5L FORD)
	04576100BF	4	STUD M14-2.0 X 540 G5 ZINC
10	043123	4	WASHER LOCK M14
11	051779	4	NUT HEX M14-2.0 G8 YEL CHR
12	0E7587	1	ASSY BRUSH HOLDER 390/HSB
13	023365	1	WASHER SHAKEPROOF INT #8
14	0C3993	4	SCREW HHTT M4-0.7 X 25 BP
15	057192	4	SCREW SHC M10-1.5 X 30 G12.9
16	0A2602	1	WASHER FLAT .688 ID X 3.25 OD
17	042558	1	KEY SQ 3/8 X 1 STEEL
18	0A2601	1	SCREW HHC M16-2.0 X 45 G8.8
19	022264	4	WASHER LOCK #8-M4
20	038150	4	WASHER FLAT #8 ZINC
21	077043F	1	CONDUIT FLEX 1-1/4" (30" LG - 3.0L FORD & 3.9L CHRYSLER)
	077043F	1	CONDUIT FLEX 1-1/4" (18" LG - 2.5L FORD)
ROTOR REPLACEMENT PARTS			
30	047248	1	BALL BEARING-45 MM
31	070892	1	SLIP RING -MACHINED-

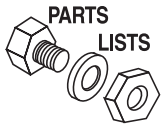

**Section 7 - Exploded Views and Parts**

**QUIETSOURCE™ Liquid-cooled 30 kW Generators**

**Muffler – Drawing No. 0F0968-B**

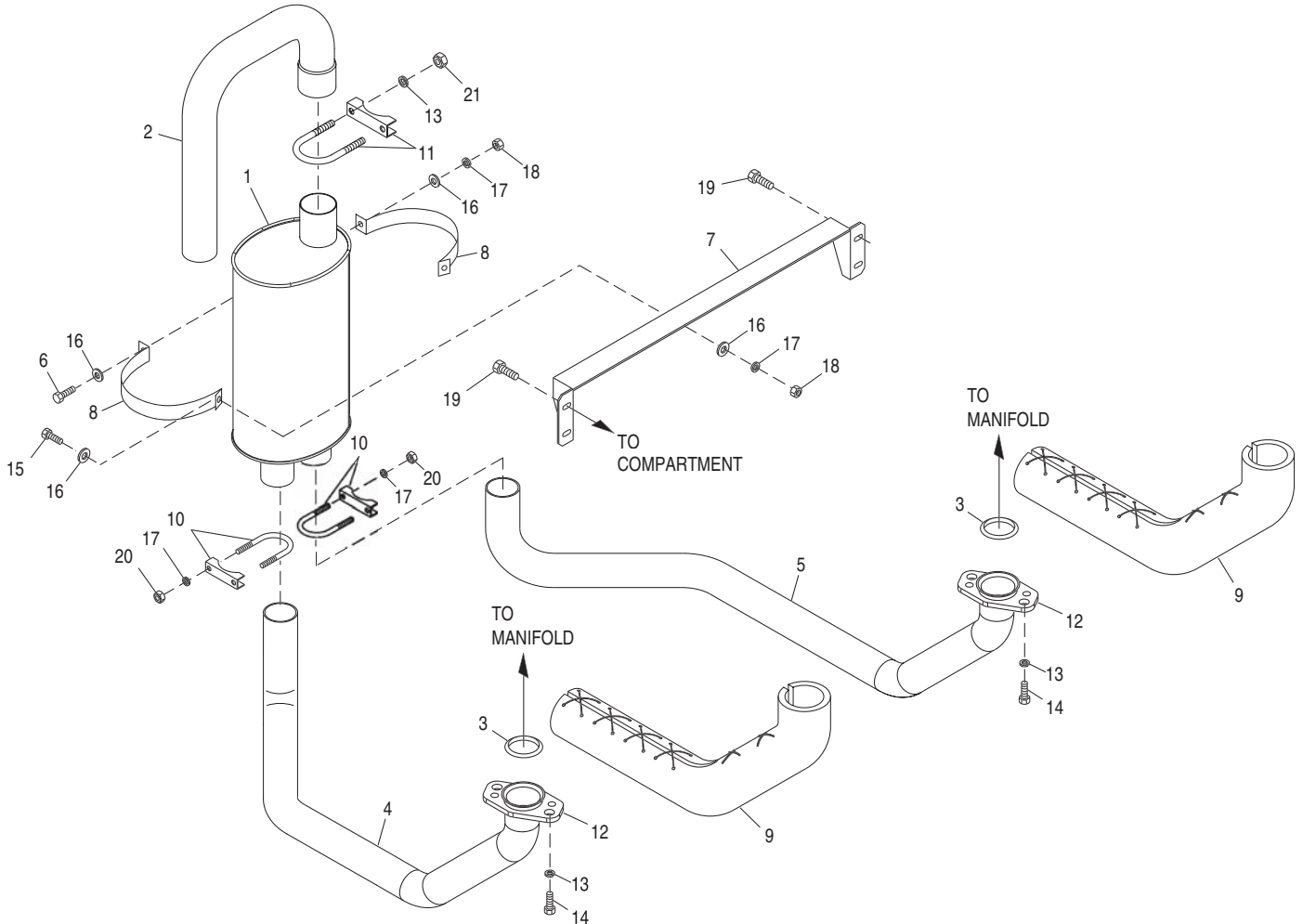

ITEM	PART NO.	QTY.	DESCRIPTION	ITEM	PART NO.	QTY.	DESCRIPTION
1	0F0738	1	MUFFLER 7"X9"-(2)2"IN/2.5"OUT	12	0E8816	2	EXHAUST FLANGE 2" PIPE
2	0F6258	1	PIPE MUFFLER OUT	13	085917	8	WASHER LOCK 3/8 SS
3	044149	2	GASKET EXHAUST RING	14	0D2611	4	SCREW HHC 3/8-16 X 1-3/4 SS
4	0F1008	1	EXHAUST PIPE LH 3.0L HSB	15	039253	2	SCREW HHC M8-1.25 X 20 G8.8
5	0F1009	1	EXHAUST PIPE RH 3.0L HSB	16	022145	4	WASHER FLAT 5/16-M8 ZINC
6	039288	1	SCREW HHC M8-1.25 X 55 G8.8	17	022129	7	WASHER LOCK M8-5/16
7	0E5914	1	BRACKET MUFFLER 3.0L FORD HSB	18	045771	3	NUT HEX M8-1.25 G8 YEL CHR
8	0E8726	2	STRAP MUFFLER	19	0C2454	4	SCREW TH-FRM M6-1 X 16 N WA Z/JS
9	0E0170	2	EXHAUST BLANKET 750MM	20	022259	4	NUT HEX 5/16-18 STEEL
10	036797	2	BOLT U 5/16-18 X 2.25	21	022241	2	NUT HEX 3/8-16 STEEL
11	080762	1	BOLT U 3/8-16 X 2.62				

Section 7 - Exploded Views and Parts  
 QUIETSOURCE™ Liquid-cooled 30 kW Generators  
 Air Cleaner – Drawing No. 0E8189-A

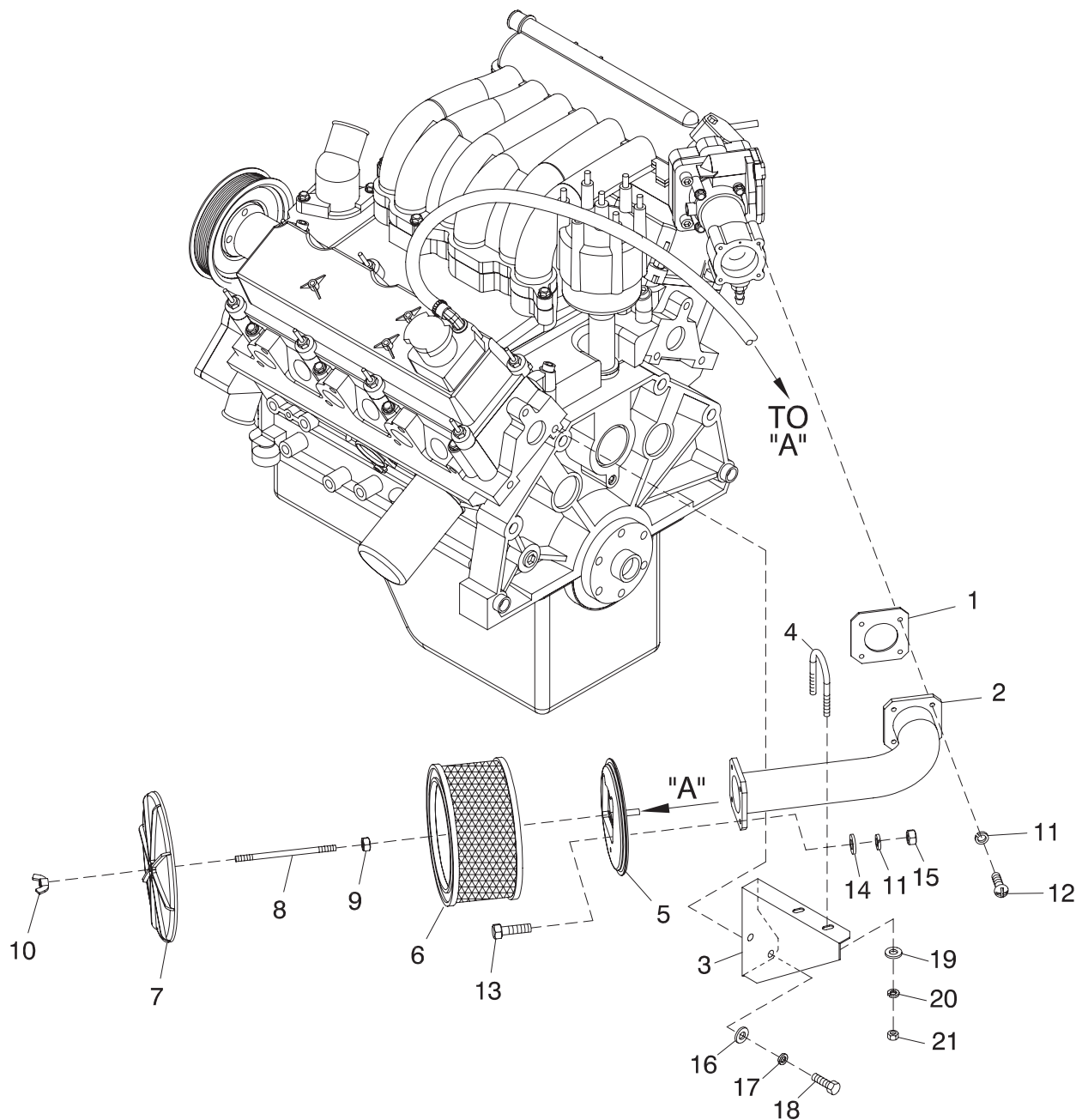
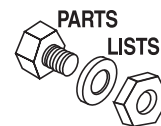

ITEM	PART NO.	QTY.	DESCRIPTION	ITEM	PART NO.	QTY.	DESCRIPTION
1	0E5193	1	PLATE AIR CLEANER ADAPTER	11	049226	8	WASHER LOCK M5
2	0E8200	1	TUBE AIR INTAKE 3.0L FORD	12	049815	4	SCREW HHC M5-0.8 X 16 G8.8
3	0E8201	1	BRACKET AIR INTAKE 3.0L FORD	13	052619	4	SCREW HHC M5-0.8 X 20 G8.8
4	036434	1	BOLT U 5/16-18 X 2.09	14	051713	4	WASHER FLAT M5
5	0E0519A	1	ADAPTER CARBURETOR W/PVC CONN	15	051716	4	NUT HEX M5-0.8 G8 YEL CHR
6	0C8127	1	ELEMENT AIR CLEANER	16	022131	2	WASHER FLAT 3/8-M10
7	0A5547	1	COVER - AIR CLEANER	17	046526	2	WASHER FLAT M10
8	062974	1	STUD TH 1/4-20 X 4-1/2 G2 ZNC	18	051755	2	SCREW HHC M10-1.5 X 16 G8.8
9	022127	1	NUT HEX 1/4-20 STEEL	19	022145	2	WASHER FLAT 5/16-M8 ZINC
10	037561	1	NUT WING 1/4-20 NYLK	20	022129	2	WASHER LOCK M8-5/16
				21	022259	2	NUT HEX 5/16-18 STEEL