

# QUIETSOURCE™

## Owner's Manual

Liquid-cooled, Prepackaged  
Standby Generators

Model No: 005012-1  
37kW NG, 40kW LP



**This manual should remain with the unit.**

—▲ CAUTION ▲—

**ONLY QUALIFIED ELECTRICIANS OR CONTRACTORS  
SHOULD ATTEMPT INSTALLATION!!**

**Section 7 - Exploded Views and Parts**

**40kW Liquid-cooled Generators  
Enclosure – Drawing No. 0F4930-C**

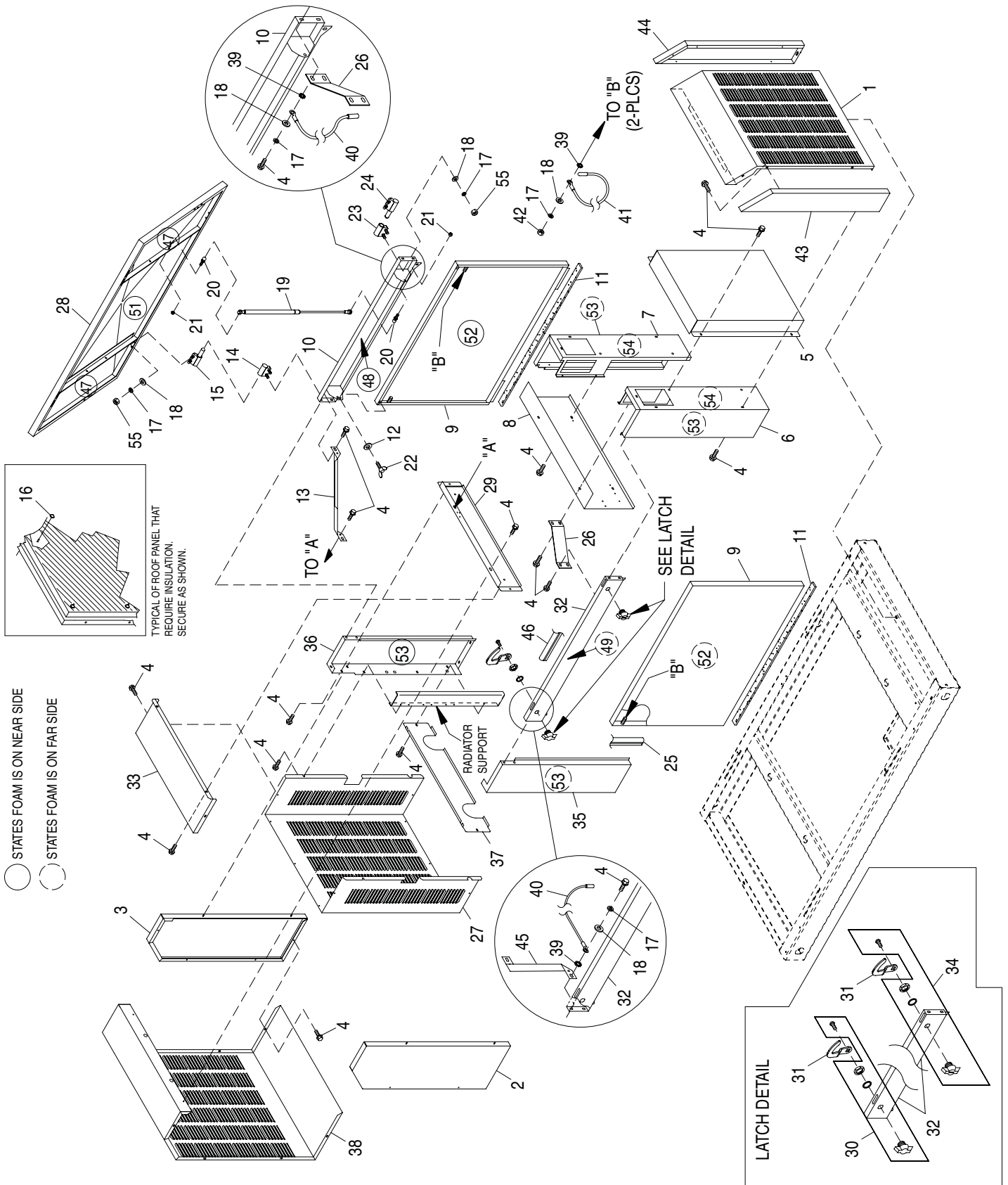

○ STATES FOAM IS ON NEAR SIDE  
 ○ STATES FOAM IS ON FAR SIDE

Section 7 - Exploded Views and Parts

40kW Liquid-cooled Generators  
Enclosure – Drawing No. 0F4930-C

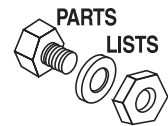

ITEM	PART NO.	QTY.	DESCRIPTION
1	0E8418	1	DUCT INTAKE MID AL
2	0E8414	1	DUCT DISCHARGE RH AL
3	0E8413	1	DUCT DISCHARGE LH AL
4	0C2454	62	SCREW TH-FRM M6-1 X 16 N WA Z/JS
5	0E7807	1	BAFFLE REAR BOTTOM
6	0E5902	1	POST CORNER LH REAR HSB AL
7	0E5903	1	POST CORNER RH REAR HSB AL
8	0E8387	1	BAFFLE REAR TOP
9	0E5912	2	DOOR SIDE HSB AL
10	0F5570	1	SUPPORT RH SIDE HSB AL
11	089961	2	FOAM STRIP 3/4" WIDE X 3/16" THK (40" LG)
12	0A2115	4	WASHER NYLON .257
13	0E8404	1	BRACKET STIFFENER RH FRONT
14	0D2538A	1	HINGE LIFT OFF TYPE B KNUCKLE
15	0D2538	1	HINGE LIFT OFF TYPE B PIN
16	078115	8	WASHER SELF LOCKING DOME
17	022097	12	WASHER LOCK M6-1/4
18	022473	12	WASHER FLAT 1/4-M6 ZINC
19	0E7570	2	GAS SPRING
20	0E7571	4	BALL STUD GAS SPRING MOUNT
21	070015	4	NUT HEX 5/16-18 LOCK
22	0E7662	4	SCREW WING M6-1.00 X 25
23	0D2537A	1	HINGE LIFT OFF TYPE A KNUCKLE
24	0D2537	1	HINGE LIFT OFF TYPE A PIN
25	0D2023	2	TRIM VINYL SELF GRIPPING (91" LG)
26	0E7869	2	BRACKET STIFFENING BACK
27	0E8001	1	MUFFLER BOX
28	0F5568	1	ROOF HSB AL ACOUSTIC
29	0E8798	1	BRACE, FRONT TOP
30	0D3037A	1	LATCH 1/4 TURN NONLOCKING
31	0C7781	2	PAWL DOOR HSB
32	0E5910	1	SUPPORT LH SIDE HSB AL
33	0E8052	1	MUFFLER BOX TOP
34	0D3037	1	LATCH QUARTER TURN LOCKING
35	0E5900	1	POST CORNER LH FRONT HSB AL
36	0E5901	1	POST CORNER RH FRONT HSB AL
37	0F4938A	1	BRACE FRONT BOTTOM
38	0E8415	1	DUCT DISCHARGE MID AL
39	026850	4	WASHER SHAKEPROOF EXT 1/4 STL
40	0912970063	2	ASSY WIRE 14AWG 7.5 #0 GRN/YEL
41	0912970064	2	ASSY WIRE 14AWG 7.5 #0 GRN/YEL
42	049813	2	NUT HEX M6 X 1.0 G8 YEL CHR
43	0E8416	1	DUCT INTAKE LH AL
44	0E8417	1	DUCT INTAKE RH AL
45	0E8665	1	BRACKET STIFFENER LH FRONT
46	0D2023	1	TRIM VINYL SELF GRIPPING (165.5" LG)
47	0E7829N	2	AI ROOF PANEL 2
48	0E7829T	1	AI SUPPORT RH PANEL
49	0E7829S	1	AI SUPPORT LH PANEL
50 *	0E8442	1	KIT INSULATION 3.9L HSB
51	0E7829A	1	AI ROOF PANEL 1
52	0E7829B	2	AI DOOR PANEL
53	0E7829P	4	AI CORNER POST PANEL 1
54	0E7829R	2	AI CORNER POST PANEL 2
55	043116	8	SCREW HHC M6-1.0 X 12 G8.8

\* ALL ITEMS NOTATED WITH "AI" ARE COMPONENTS OF 0E8442

**Section 7 - Exploded Views and Parts**

**40kW Liquid-cooled Generators  
Control Panel – Drawing No. 0E7118-K**

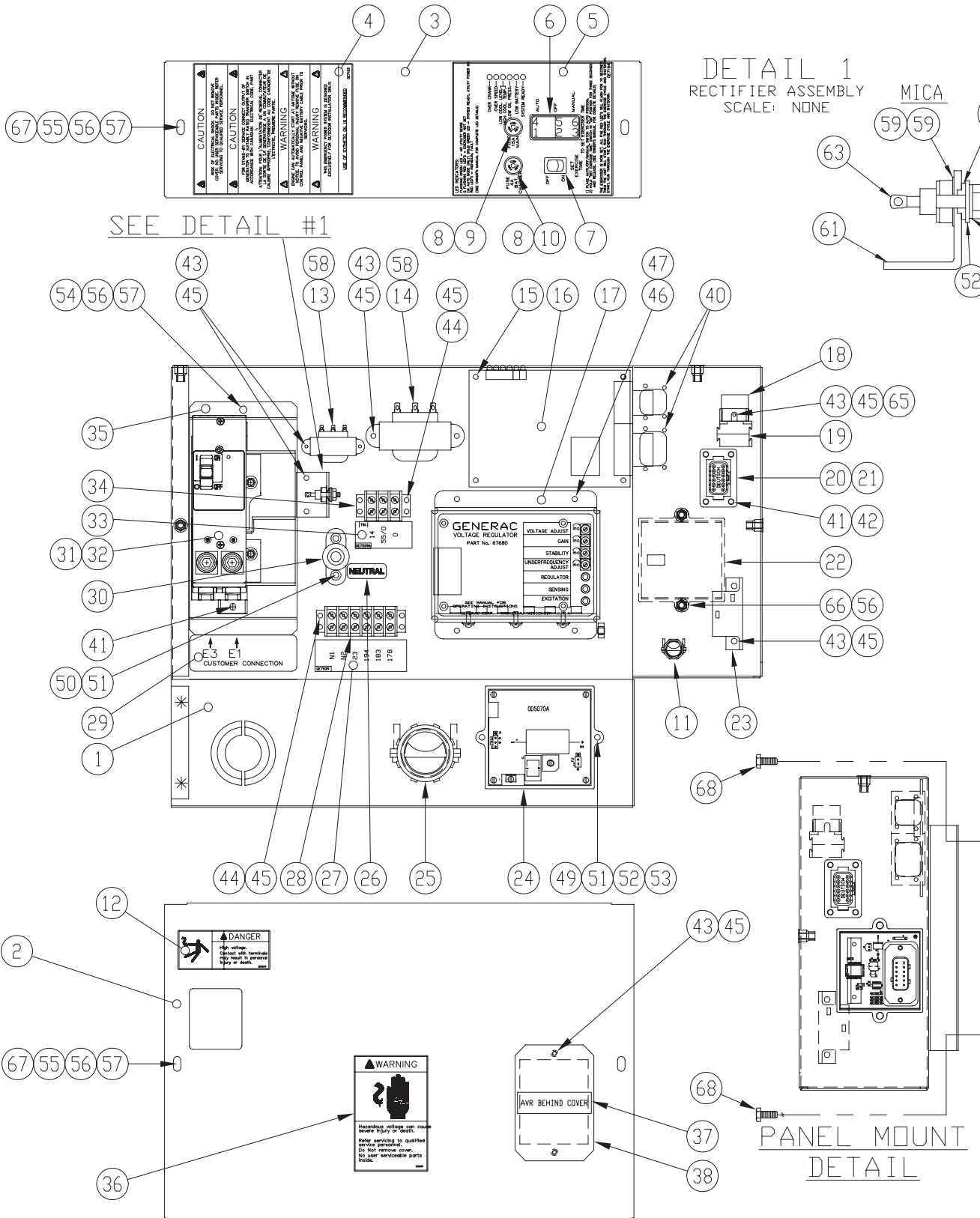

**Section 7 - Exploded Views and Parts**  
**40kW Liquid-cooled Generators**  
**Control Panel – Drawing No. 0E7118-K**

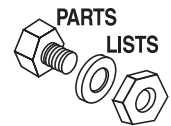

ITEM	PART NO.	QTY.	DESCRIPTION	ITEM	PART NO.	QTY.	DESCRIPTION
1	0E7195	1	CONTROL BOX HSB	37	0C1127	1	DECAL AVR COVER
2	0E7196	1	COVER FRONT PANEL HSB	38	0A1441B	1	COVER PLATE, AVR
3	0E7197	1	COVER TOP PANEL HSB	39	0E7128	1	HARNNESS CNTRL PNL (NOT SHOWN)
4	0E7193	1	DECAL WARNINGS HSB				
5	0E7194	1	DECAL CONTROLS HSB	40	0E7358	8	SCREW PPPH HI-LO #4-24 X 3/8
6	0E4494	1	SWITCH ROC DPDT ON-OFF-ON	41	074908	6	SCREW HHTT M5-0.8 X 10 BP
7	082573	1	SWITCH ROCKER DPST 125V SPD	42	0C5141	1	CONN DEUTSCH GASKET 8/12 POS DT
8	032300	2	HOLDER FUSE				
9	022676	1	FUSE 15A X AGC15	43	0C2699	11	SCREW PHTT #6-32 X 3/8 ZYC
10	067682B	1	FUSE 4A SLO BLO GLASS	44	0C2323	4	SCREW PHTT #6-32 X 5/8 ZYC
11	060015	1	FITTING CONDUIT 90D 3/8"	45	022155	15	WASHER LOCK #6
12	054199	1	DECAL DANGER HIGH VOLTAGE	46	0C2265	4	SCREW PHTT M4-0.7 X 12 ZYC
13	0C2657	1	TRANSFRMR 16V 6VA	47	022264	4	WASHER LOCK #8-M4
14	099076	1	TRANSFORMER 16V 56VA	49	020911	2	SCREW PPHM M5-0.8 X 30 ZINC
15	040213	2	PCB SUPPORT SNAP-IN 1/4"	50	066849	2	SCREW HHTT M5-0.8 X 16
16	0E9668	1	ASSY PCB HSB CONTROLLER	51	022152	4	WASHER LOCK #10
17	067680	1	ASSY VOLTAGE REGULATOR 60HZ	52	023897	3	WASHER FLAT #10 ZINC
18	0E6875A	1	RELAY 12VDC C FORM W/DIODE	53	051716	2	NUT HEX M5-0.8 G8 YEL CHR
19	0E6881 *	REF.	SOCKET RELAY	54	090388	2	SCREW HHTT M6-1.0 X 12 ZINC
20	0C5139 *	REF.	CONN DEUTSCH RECEPT GY/FLN	55	042568	4	SCREW HHC M6-1.0 X 20 G8.8
21	0C5142 *	REF.	CONN DEUTSCH RECEPT WDGE BLKHD	56	022097	8	WASHER LOCK M6-1/4
				57	022473	6	WASHER FLAT 1/4-M6 ZINC
22	0E3161	1	ASSY BOSCH GOV DRIVER	58	0441140187	2	WIRE ASSY 3" X (2) 3/16" TABS
23	054450	1	CIRCT BRK 5.5 X 1 ETA 46-500-P	59	070370	2	WASHER MICA .203
24	0D5070A	1	ASSY 2A 12V UL BATTERY CHARGER	60	023762	1	WASHER SHAKEPROOF EXT #10 STL
25	0E2514	1	FITTING CONDUIT STR 1-1/2"	61	055444	1	HEATSINK
26	0A9457	1	DECAL NEUTRAL	62	030468	1	WASHER STEP NYLON .20
27	0E7539	1	DECALCUSTOMER CNNCTN XFER SW	63	049939	1	RECTIFIER MSC 12A 600V 1N1206R
				64	022158	1	NUT HEX #10-32 STEEL
28	046357 *	REF.	BLOCK TERM 20A 6 X 6 X 1100V	65	022985	1	WASHER FLAT #6 ZINC
29	0D3719B	1	DECAL CUSTOMER CNNCTN	66	038750	2	SCREW HHC M6-1.0 X 30 G8.8
30	057073	1	JUNCTION BLOCK 3/8-16	67	0A2115	4	WASHER NYLON .257
31	0E7283	1	CB 0150A2P240V S QN2 LL	68	0C2454	4	SCREW THF M6-1 X 16 N WA Z/JS
	0E3628	1	CB 0200A2P240V S QN2 LL	69	0F6146	1	HANG TAG 2 WIRE START (NOT SHOWN)
32	0E3664	1	BASE QN CIRCUIT BREAKER				
33	0E7539A	1	DECAL TB1 HSB CONTROL PANEL				
34	0D4698 *	REF.	BLOCK TERM 20A 6 X 3 X 1100V	* ITEMS INCLUDED AS PART OF I/N 39			
35	0E7252	1	BRACKET CB 221.5 X 102				
36	0C1229	1	DECAL WARNING ELECTRICAL SHOCK				



**Section 7 - Exploded Views and Parts**

**40kW Liquid-cooled Generators**

**Engine – Drawing No. 0E8121-H**

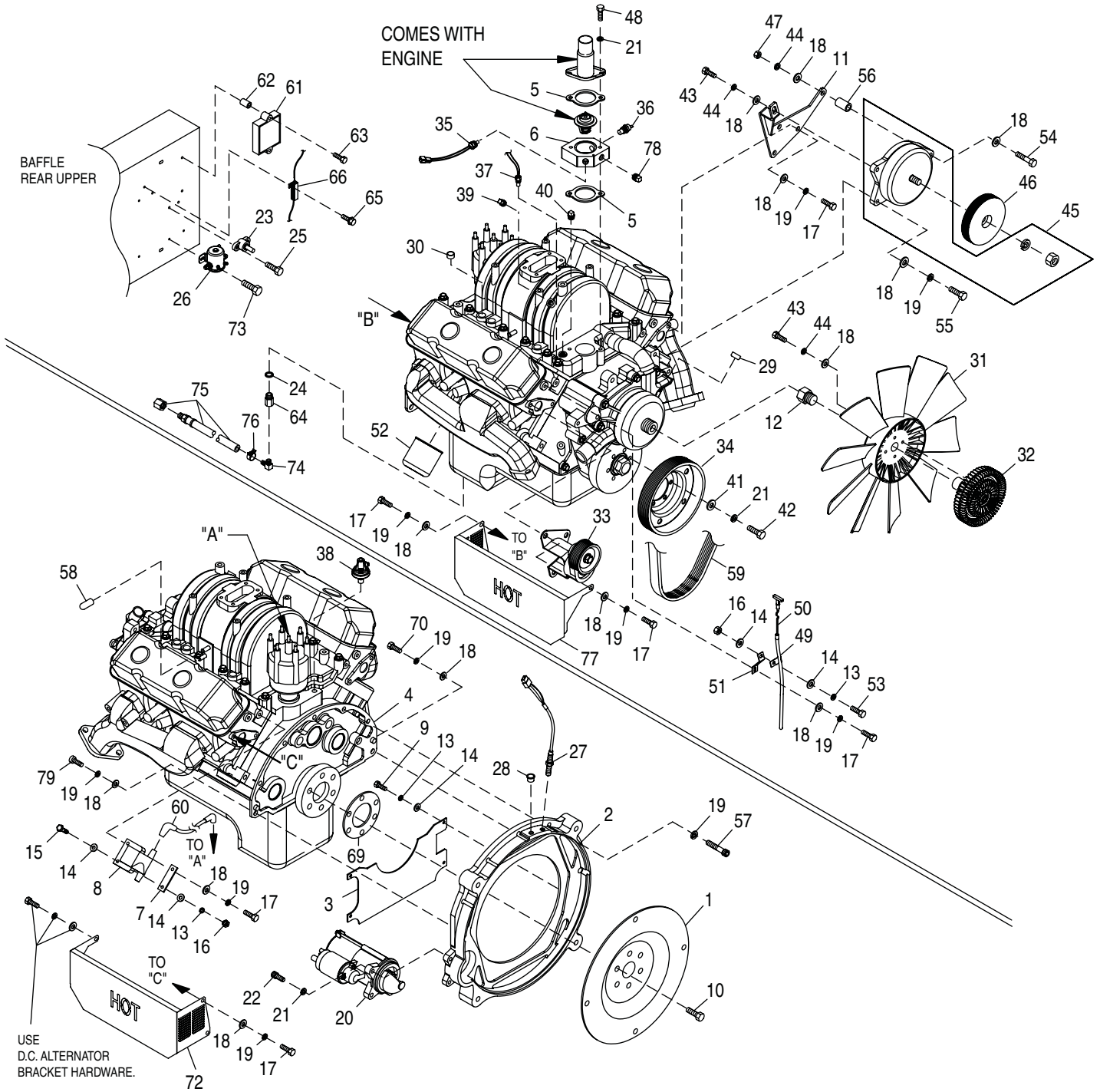

Section 7 - Exploded Views and Parts

40kW Liquid-cooled Generators  
Engine – Drawing No. 0E8121-H

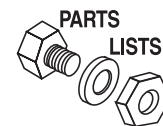

ITEM	PART NO.	QTY.	DESCRIPTION	ITEM	PART NO.	QTY.	DESCRIPTION
1	0E5048A	1	FLEXPLATE 3.9L HSB	39	050873A	1	PLUG PIPE 1/4 CSK W/ VIBRA SL
2	0E7477	1	MACHINING 3.9L ENGINE ADAPTOR	40	031919	1	PLUG STD PIPE 3/8
3	0E6703	1	COVER FLYWHEEL ACCESS				COUNTERSUNK
4	0E8336	REF	REWORK 3.9L CHRYSLER ENGINE	41	022145	6	WASHER FLAT 5/16-M8 ZINC
5	0E7841	2	GASKET THERMOSTAT ADAPTOR	42	030795	6	SCREW HHC 5/16-18 X 1 G5
6	0E7254	1	MACH THERM ADAPTOR 3.9L CHRY	43	051756	5	SCREW HHC M10-1.5 X 20 G8.8
7	0E7956	1	BRACKET IGNITION COIL	44	046526	6	WASHER LOCK M10
8	0E7953	1	COIL IGNITION 3.9L CHRYSLER	45	0A1232A	1	ASSEMBLY, D.C. ALTERNATOR
9	047411	4	SCREW HHC M6-1.0 X 16 G8.8	46	0A7801B	1	PULLEY POLY-V 82 OD
10	0E8591	6	BOLT AUTO TRANS CRANKSHAFT	47	045772	1	NUT HEX M10-1.5 G8 YEL CHR
11	0E7921	1	BRACKET ALTERNATOR	48	022403	2	SCREW HHC 5/16-18 X 2 G5
12	0E7749	1	FAN SPACER ENGINE COOLING	49	0E7950	1	TUBE DIPSTICK 3.9L CHRYSLER
13	022097	7	WASHER LOCK M6-1/4	50	0E7951	1	DIPSTICK OIL LEVEL 3.9L CRYSLR
14	022473	10	WASHER FLAT 1/4-M6 ZINC	51	0E8445	1	BRACKET DIPSTICK TUBE
15	049721	2	SCREW HHC M6-1.0 X 35 G8.8 BLK	52	0E7415	1	OIL FILTER 3.9L CHRYSLER
16	049813	3	NUT HEX M6 X 1.0 G8 YEL CHR	53	042568	1	SCREW HHC M6-1.0 X 20 G8.8
17	036833	11	SCREW HHC 3/8-16 X 1 G8	54	061652	1	SCREW HHC M10-1.5 X 85 G8.8
18	022131	21	WASHER FLAT 3/8-M10 ZINC	55	031578	1	SCREW HHC 3/8-16 X 1-1/2 G8
19	022237	14	WASHER LOCK 3/8	56	082120	1	SPACER .41 X .75 X .39 ST/ZNC
20	0E6729	1	STARTER DELCO-REMY 12V	57	023645	5	SCREW SHC 3/8-16 X 1.25 G8.8 Z
21	022129	11	WASHER LOCK M8-5/16	58	0E9974	1	CAP VINYL 3/8" ID X 1" DP BLK
22	049821	3	SCREW SHC M8-1.25 X 30 G12.9	59	0D3488A	1	BELT SERPENTINE 69.39"
23	057073	1	JUNCTION BLOCK 3/8-16	60	0E7954	1	CABLE IGN COIL 3.9L CHRYSLER
24	052677	1	WASHER NYLON .50 X .87 X .06	61	0E8309	1	ASSY IGNITION MODULE 3.9L
25	066849	2	SCREW HHTT M5-0.8 X 16	62	029187	2	SPACER .19 X .31 X .50 PL
26	056739	1	RELAY SOLENOID 12VDC PNL MNT	63	032712	2	SCREW HHTT #10-32 X 1.75 CZ
27	0D2244M	1	ASSY MAGPICKUP (3/8-24 MALE)	64	054455	1	ADP OIL DRN 1/2-20
28	087599	1	PLUG PLASTIC 3/8 NPT	65	0E8606	2	SCREW PPH TAPPING #4 X 3/8" LG
29	0E0992B	REF	PLUG EXPANSION 21/32" OD (WATER PUMP) (QTY 1)	66	0E8642	REF	ASSEMBLY RESISTOR
30	0E0992A	REF	PLUG EXPANSION 14.1 OD (INJECTOR HOLE) (QTY 6)	67	0E8597	1	HARNES 3.9L CHRYSLER ENGINE (NOT SHOWN)
31	0E7754	1	COOLING FAN 10-BLADE (KYSAIR)	68	0E8755	1	HARNES IGNITION 3.9L CHRY (NOT SHOWN)
32	0E7854	1	CLUTCH COOLING FAN	69	0E8731	1	PLATE FLEX DISK SPACER
33	0E7855	1	TENSIONER W/BRACKET	70	026076	1	SCREW SHC 3/8-16 X 1.5 G8.8 NZ
34	0E7952	1	PULLEY CRANKSHAFT 3.9L CRYSLR	72	0F1444A	2	HEAT SHEILD L/H SIDE
35	0E0561	1	ASSY WATER LEVEL SENSOR C/E PL	73	0C2454	2	SCREW THF M6-1 X 16 N WA Z/JS
36	035606	1	SENSOR HI COOLANT SHUTDOWN	74	043790	1	BARBED EL 90 3/8 NPT X 3/8
37	061012	1	PLUG STD PIPE 1/8 SOCKET HEAD	75	069860C	1	HOSE OIL DRAIN ASSY 21"
38	0A8584	1	SWITCH OIL PRESSURE 10 PSI 2POL	76	048031J	REF	HOSE CLAMP BAND 5/8"
				77	0F1444	1	HEAT SHIELD R/H SIDE
				78	026925	1	PLUG STD PIPE 3/8 STEEL SQ HD
				79	026257	1	SCREW SHC 3/8-16 X 2 G8.8 NZ

Section 7 - Exploded Views and Parts

40kW Liquid-cooled Generators  
Radiator – Drawing No. 0E8102-F

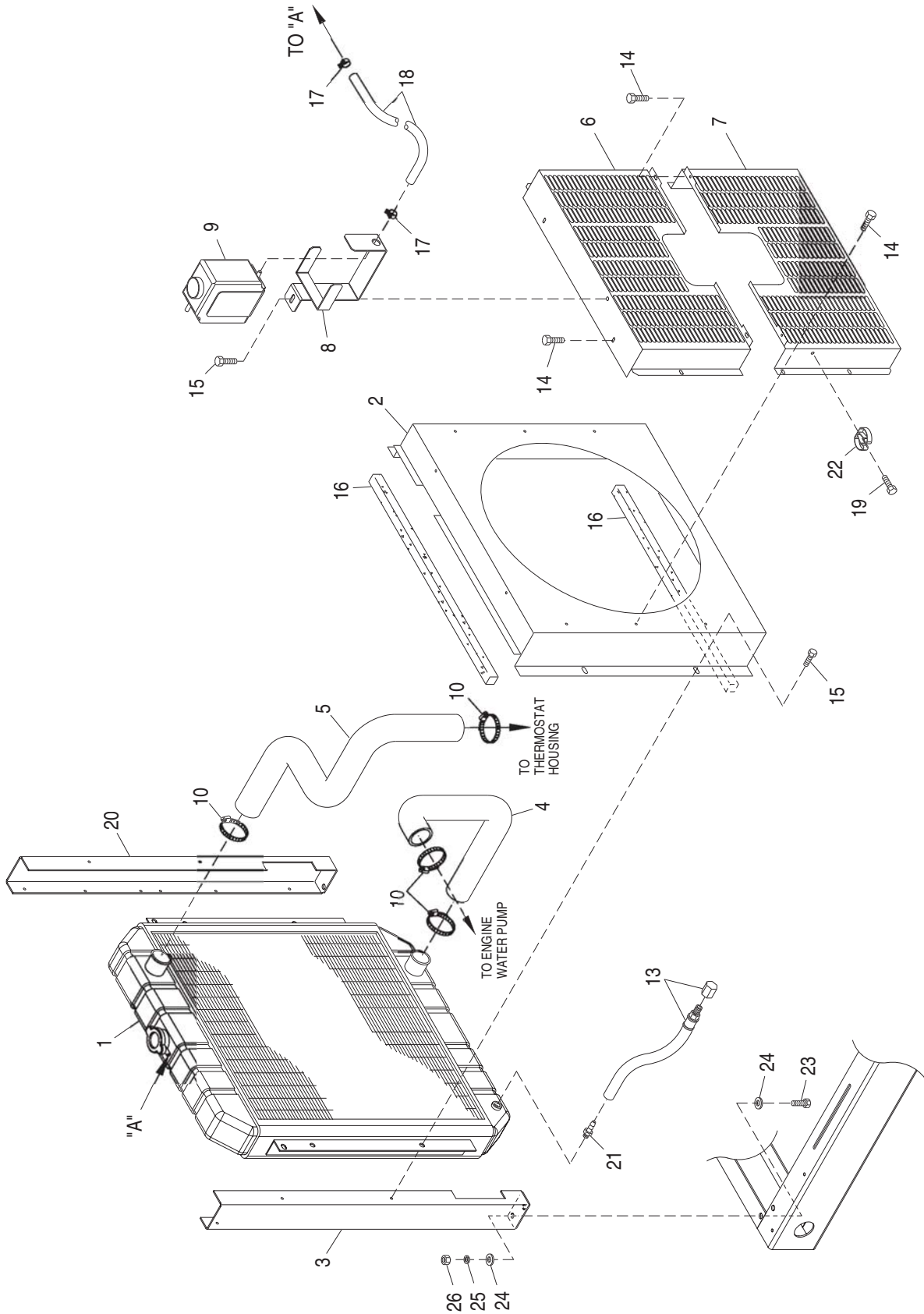



Section 7 - Exploded Views and Parts

40kW Liquid-cooled Generators  
Radiator – Drawing No. 0E8102-F

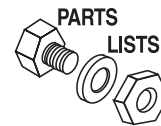

ITEM	PART NO.	QTY.	DESCRIPTION
1	0D7825A	1	RADIATOR COPPER BRASS
2	0D7174C	1	VENTURI,3.9L CRYSLR HSB 22"FAN
3	0E7640	1	RADIATOR SUPPORT L/H SIDE
4	0E7924	1	HOSE LOWER RADIATOR
5	0F2853	1	HOSE, RADIATOR UPPER, 3.9L
6	0D8252	1	FAN GUARD, TOP
7	0D8251	1	FAN GUARD, BOTTOM
8	0E0726	1	BRACKET, WATER BOTTLE 1.5L MIT
9	076749	1	TANK COOLANT RECOVERY
10	035685	4	CLAMP HOSE #28 1.32-2.25
13	069860C	1	HOSE OIL DRAIN ASSY 21"
14	058443	17	SCREW CRIMPTITE 1/4-20 X 5/8
15	0C2454	5	SCREW TH-FRM M6-1X16 N WA Z/JS
16	052250	2	TAPE FOAM 1 X 1 (27"LG)
17	048031C	1	CLAMP HOSE BAND 1/4
18	029032	1	HOSE 9/32 ID (30" LG)
19	0A2111	1	SCREW SWAGE 10-32 X 5/16 Z/YC
20	0E7640A	1	RADIATOR SUPPORT R/H SIDE
21	035461	1	BARBED STR 1/4NPT X 3/8
22	065852	1	SPRING CLIP HOLDER .37-.62
23	051756	4	SCREW HHC M10-1.5 X 20 G8.8
24	022131	8	WASHER FLAT 3/8-M10 ZINC
25	046526	4	WASHER LOCK M10
26	045772	4	NUT HEX M10-1.5 G8 YEL CHR

**Section 7 - Exploded Views and Parts**

**40kW Liquid-cooled Generators  
Fuel System – Drawing No. 0E8122-H**

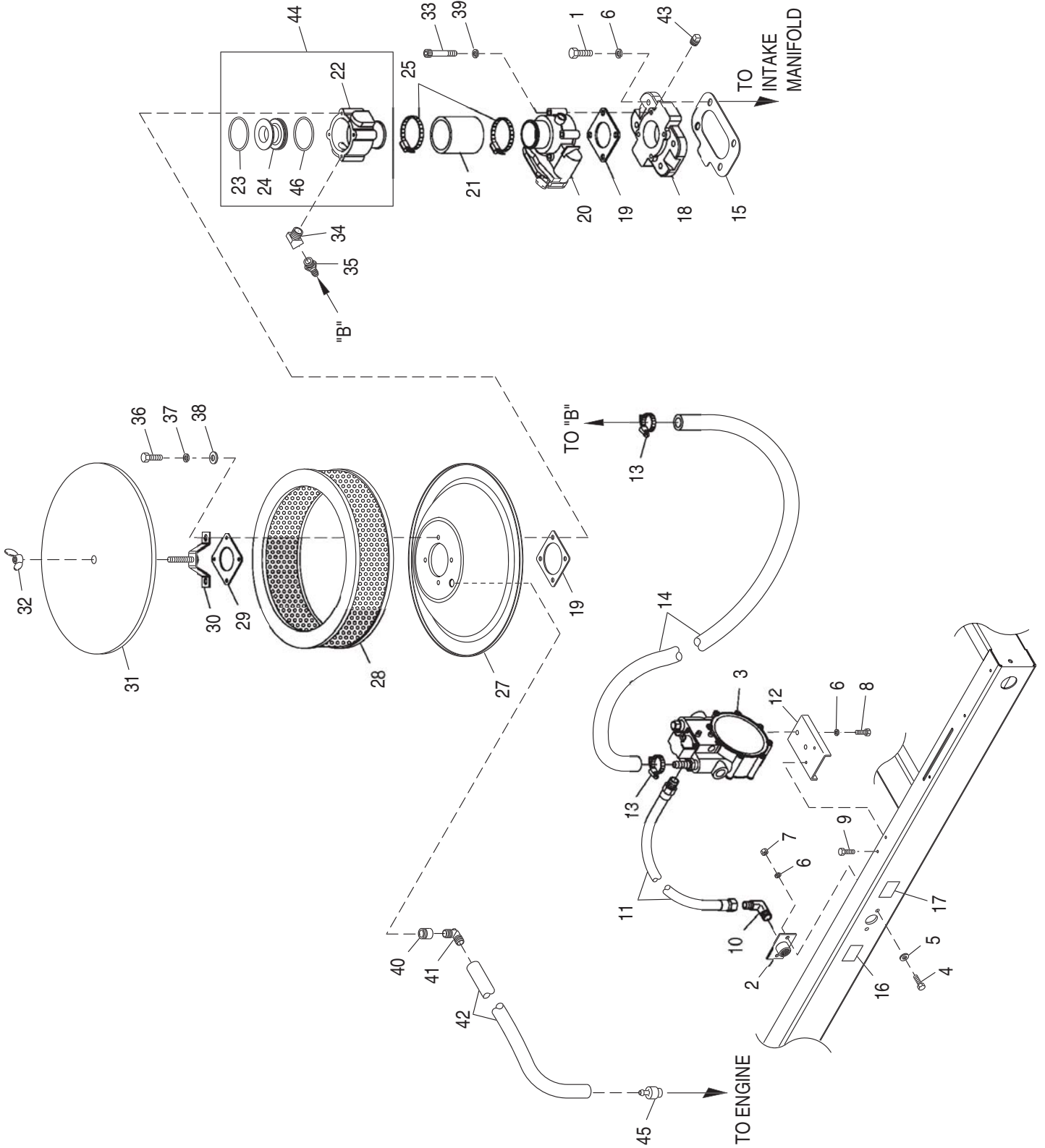

Section 7 - Exploded Views and Parts

40kW Liquid-cooled Generators  
Fuel System – Drawing No. 0E8122-H

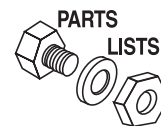

ITEM	PART NO.	QTY.	DESCRIPTION
1	033212	4	SCREW HHC 5/16-18 X 1-1/4 G5
2	075580	1	FLANGE FUEL INLET
3	0E8365	1	ASSY REG. 3.9L N/G-LPV 1800RPM
4	039253	2	SCREW HHC M8-1.25 X 20 G8.8
5	022145	2	WASHER FLAT 5/16 ZINC
6	022129	8	WASHER LOCK M8-5/16
7	045771	2	NUT HEX M8-1.25 G8 YEL CHR
8	042907	2	SCREW HHC M8-1.25 X 16 G8.8
9	0C2454	2	SCREW TH-FRM M6-1 X 16 N WA Z/JS
10	026307	1	ELBOW 90D STREET 3/4
11	0E1056	1	FUEL HOSE ASSY NAT.GAS/L.P.V.
12	0E6584	1	BRACKET REGULATOR 3.0L FORD HSB
13	057822	2	CLAMP HOSE #8 .53-1.00
14	059194	1	HOSE 5/8 ID LPG & NG (36" LG)
15	064945	1	GASKET CARB ADAPTOR
16	0D1509	1	DECAL INLET PRESSURE
17	050279	1	DECAL FUEL INLET NG
18	0E7839	1	MACHINING, CARBURETOR ADAPTOR
19	0E6586	2	GASKET BOSCH 32 & 40
20	0E4394	1	ACTUATOR BOSCH 40 GOVERNOR
21	040105	1	HOSE COOL 2IN ID 20R4 (2" LG)
22	0E6382B	1	VENTURI HOLDER W/40MM ACTUATOR
23	0F2119	1	O-RING 45.63 ID X 2.62 WIDTH
24	0E6376B	1	VENTURI 28 ID THROTTLE W/CHOK
25	042561	2	CLAMP HOSE #36 1.88-2.75
27	0E7929	1	BASE AIR CLEANER PLATE
28	0A4637	1	FILTER AIR 11.5" CA326
29	0E6406	1	HOLDER VENTURI
30	0E7702	1	HOLD DOWN AIR CLEANER
31	0A4632A	1	PLATE AIR CLEANER TOP
32	037561	1	NUT WING 1/4-20 NYLK
33	046580	4	SCREW SHC M6-1.0 X 45 G12.9
34	0E8286	1	STREET EL 45DEG 1/2" NPT BRASS
35	044118	1	BARBED STR 1/2NPT X 5/8
36	049815	4	SCREW HHC M5-0.8 X 16 G8.8
37	049226	4	WASHER LOCK M5
38	051713	4	WASHER FLAT M5
39	022097	4	WASHER LOCK M6-1/4
40	057796	1	GROMMET
41	057795A	1	BARBED EL 90 3/4 PLASTIC
42	052223	1	HOSE 1/2 ID SAE-30R2 FUEL/OIL
43	061012	1	PLUG STD PIPE 1/8 SOCKET HEAD
44	0E9295	1	ASSY THROTTLE 28MM
45	0F3994	1	PCV VALVE 2.5L FORD
46	0E7121	1	O-RING 47.625 ID X 2.38 WIDTH

Section 7 - Exploded Views and Parts  
40kW Liquid-cooled Generators  
Alternator – Drawing No. 0F5092-B

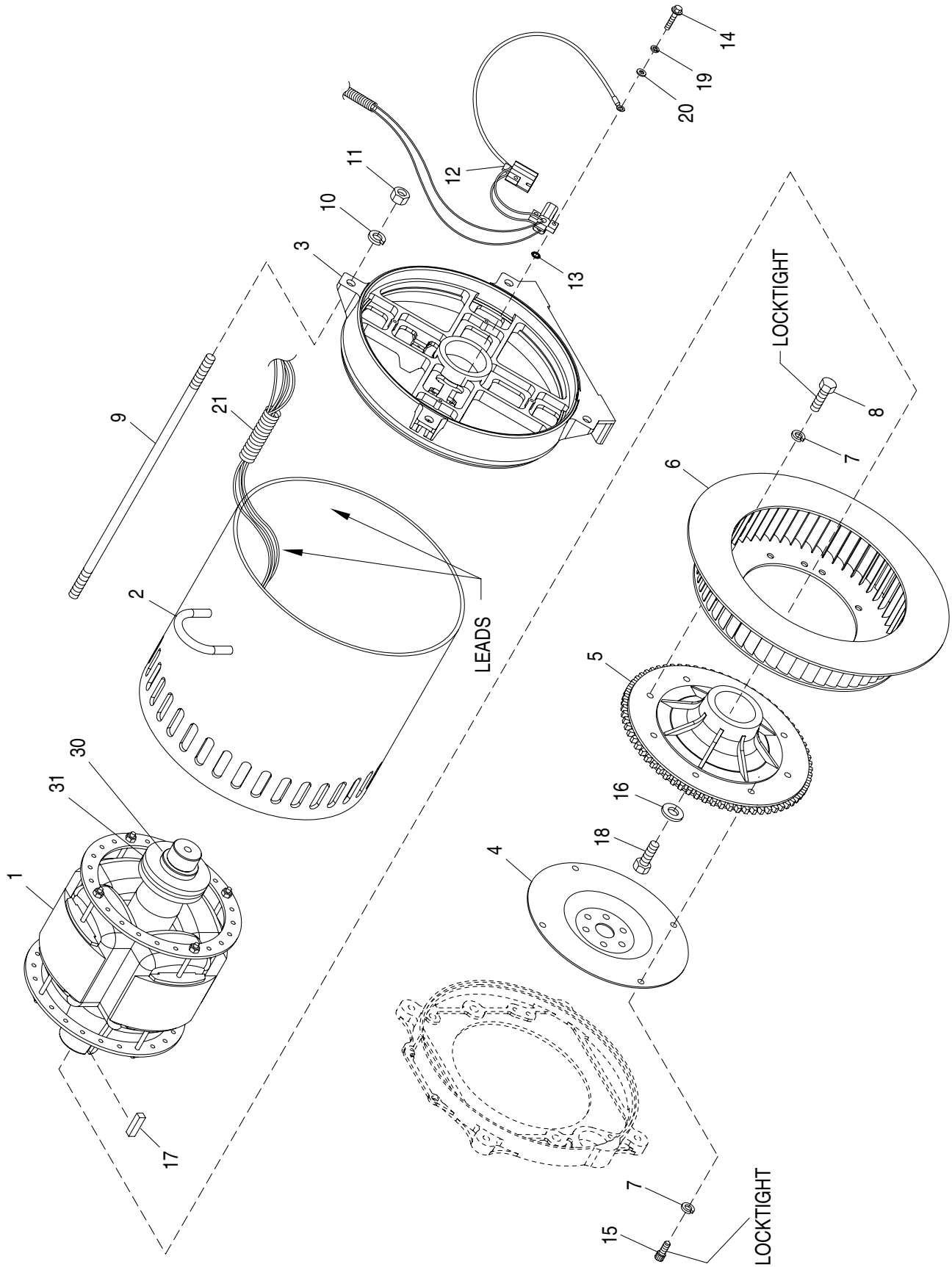

Section 7 - Exploded Views and Parts

40kW Liquid-cooled Generators  
Alternator – Drawing No. 0F5092-B

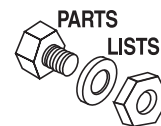

ITEM	PART NO.	QTY.	DESCRIPTION
1	0F1659A	1	ROTOR 390 15KW 1P DIRECT HSB (2.5L FORD)
	0F1657A	1	ROTOR 390 20KW 1P DIRECT HSB (2.5L FORD)
	0F1655A	1	ROTOR 390 25KW 1P DIRECT HSB (2.5L FORD)
	0F5073A	1	ROTOR 390__30AD1 HSB TECUM
	0E7413A	1	RTR 390 40KW 1P DIRECT HSB
2	0F1660A	1	STR 390 15AD HSB (382MM LONG) (2.5L FORD)
	0F1658A	1	STR 390 20AD HSB (382MM LONG) (2.5L FORD)
	0F1656A	1	STR 390 25AD HSB (382MM LONG) (2.5L FORD)
	0F5074A	1	STR-390__30AD1 HSB TECUM
	0E7412A	1	STR-390--40AD HSB (433MM LONG)
3	0E5706	1	REAR BEARING CARRIER 390/DRCT
4	0E5048	REF	FLEXPLATE 3.0L FORD
		0E5048B	REF FLEXPLATE 2.5L FORD
		0E5048A	REF FLEXPLATE HSB 3.9L CHRYSLER
5	0E6668	1	FLYWHEEL ASSY 3.0L HSB LG GEAR
6	0E6076	1	REVCOR FAN 10.75 X 2 W/PRESS DIS
7	046526	8	WASHER LOCK M10
8	051755	4	SCREW HHC M10-1.5 X 16 G8.8
9	04576100BK	4	STUD M14-2.0 X 490 G5 ZINC (3.0L FORD & 2.5L FORD)
	04576100BF	4	STUD M14-2.0 X 540 G5 ZINC
10	043123	4	WASHER LOCK M14
11	051779	4	NUT HEX M14-2.0 G8 YEL CHR
12	0E7587	1	ASSY BRUSH HOLDER 390/HSB
13	023365	1	WASHER SHAKEPROOF INT #8
14	092980	4	SCREW PPHM M4-0.7 X 25
15	057192	4	SCREW SHC M10-1.5 X 30 G12.9
16	0A2602	1	WASHER FLAT .688 ID X 3.25 OD
17	042558	1	KEY SQ 3/8 X 1 STEEL
18	0A2601	1	SCREW HHC M16-2.0 X 45 G8.8
19	022264	4	WASHER LOCK #8-M4
20	038150	4	WASHER FLAT #8 ZINC
21	077043F	1	CONDUIT FLEX 1-1/4" (30" LG - 3.0L FORD & 3.9L CHRYSLER)
	077043F	1	CONDUIT FLEX 1-1/4" (18" LG - 2.5L FORD)
ROTOR REPLACEMENT PARTS			
30	047248	1	BALL BEARING-45 MM
31	070892	1	SLIP RING -MACHINED-

**Section 7 - Exploded Views and Parts**

**40kW Liquid-cooled Generators  
Muffler – Drawing No. 0F4894-B**

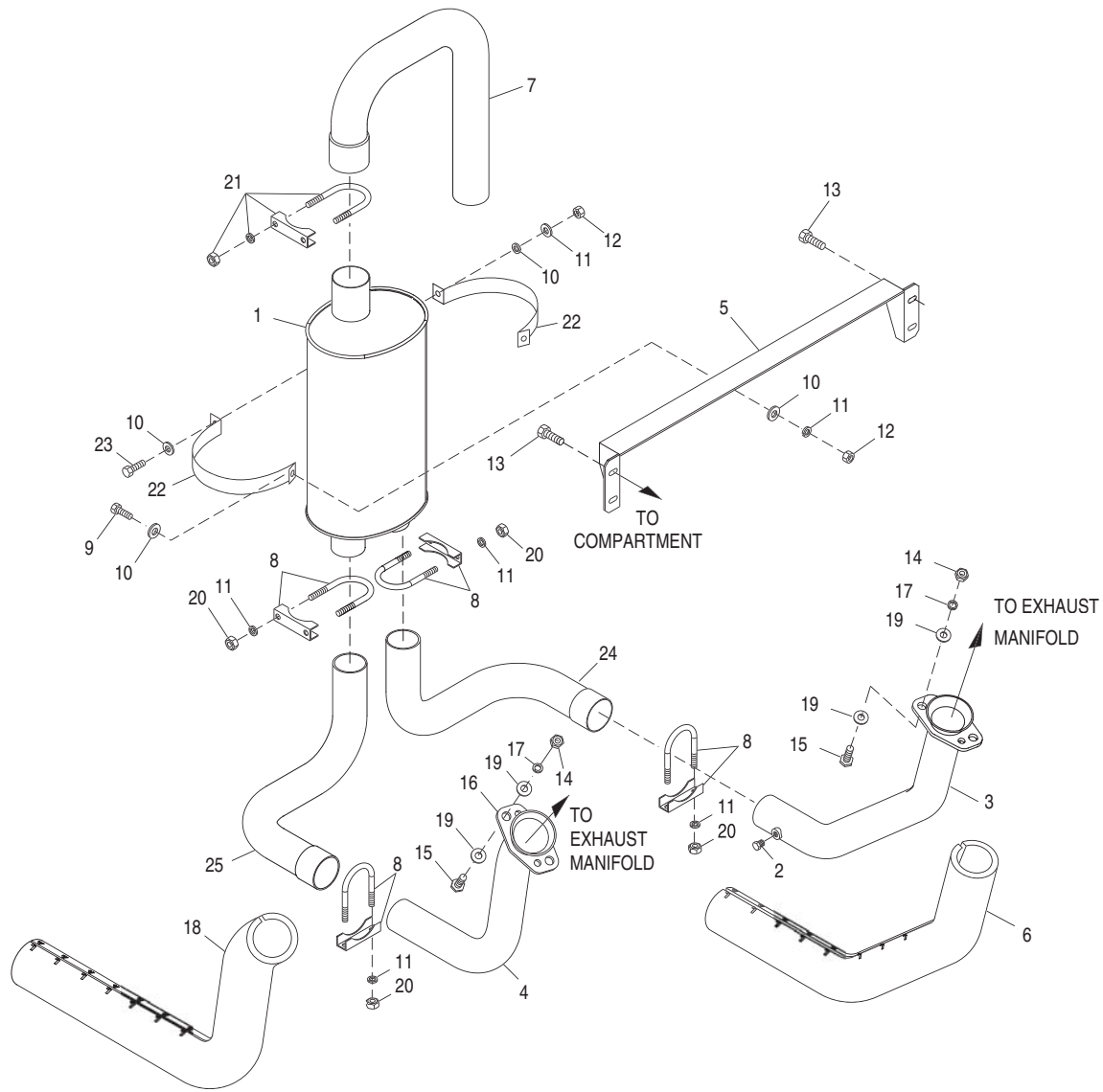

ITEM	PART NO.	QTY.	DESCRIPTION	ITEM	PART NO.	QTY.	DESCRIPTION
1	0F0738	1	MUFFLER 7"X9"-(-2)2"IN/2.5"OUT	14	052860	4	NUT TOP LOCK FL M12-1.75
2	0C9748	1	PLUG M18-1.50	15	052891	4	SCREW HHC M12-1.75 X 80 G8.8
3	0F0778	1	PIPE R/H SIDE EXHAUST MILD ST	16	0E8816	1	EXHAUST FLANGE 2" PIPE
4	0F0777	1	PIPE L/H SIDE EXHAUST MILD ST	17	051769	4	WASHER LOCK M12
5	0E5914	1	BRACKET MUFFLER 3.0L FORD HSB	18	0E0170B	1	EXHAUST BLANKET 800MM
6	0E0170C	1	EXHAUST BLANKET 675MM	19	049808	8	WASHER FLAT M12
7	0F6258	1	PIPE MUFFLER OUT	20	022259	8	NUT HEX 5/16-18 STEEL
8	036797	4	BOLT U 5/16-18 X 2.25	21	080762	1	BOLT U 3/8-16 X 2.62
9	039253	2	SCREW HHC M8-1.25 X 20 G8.8	22	0E8726	2	STRAP MUFFLER
10	022145	6	WASHER FLAT 5/16-M8 ZINC	23	039288	1	SCREW HHC M8-1.25 X 55 G8.8
11	022129	11	WASHER LOCK M8-5/16	24	0F5612	1	PIPE R/H SIDE EXHAUST MILD ST
12	045771	3	NUT HEX M8-1.25 G8 YEL CHR	25	0F6262	1	PIPE L/H SIDE EXHAUST MILD ST
13	0C2454	4	SCREW TH-FRM M6-1 X 16 N WA Z/JS				