

GENERAC MC ALTERNATOR

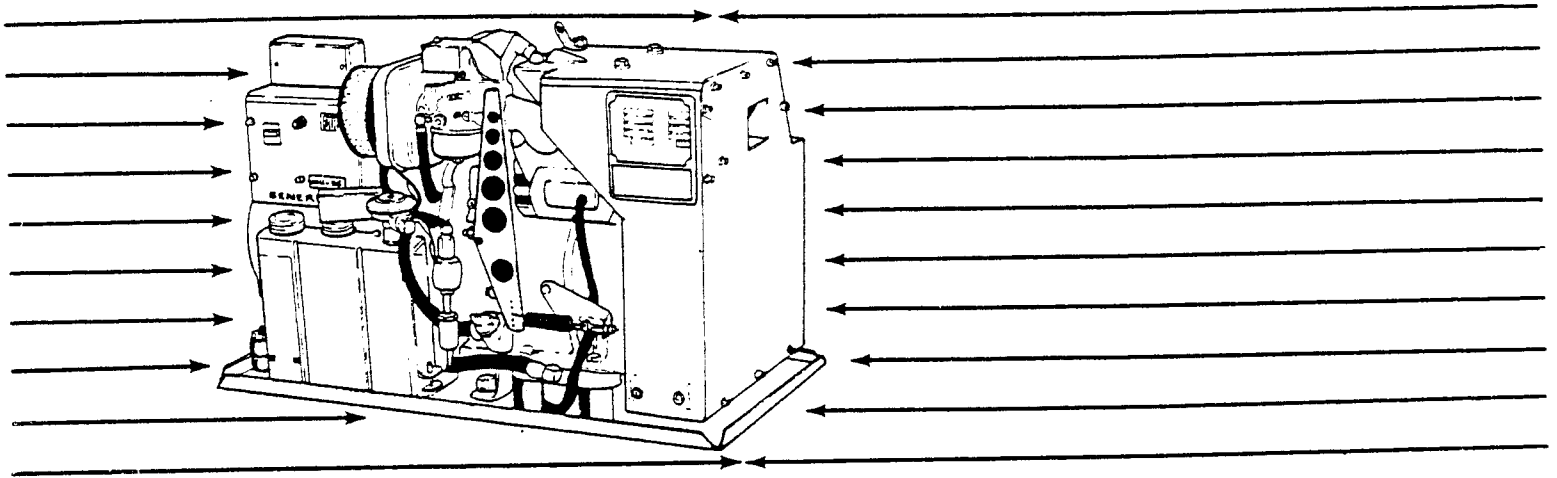

DIAGNOSTIC REPAIR MANUAL

ISSUED JANUARY 1979

P.O. BOX 8, WAUKESHA, WISCONSIN 53186
PRINTED IN U.S.A.

51834

This Repair Manual is provided to aid the technician in the analysis and repair of malfunctions that might occur in the MC alternator or its engine. Keep the Manual in a safe place and refer to it whenever necessary.

All information, illustrations and specifications contained in this Manual are based on the latest product information available at the time of publication. Generac reserves the right to make changes in any product at any time without notice.

GENERAC

P.O. BOX 8

WAUKESHA, WISCONSIN 53186

PART I GENERAL

Section 1.1 - SPECIFICATIONS

1.1.1 - Model Numbers

1.1.2 - Fuels and Oils

1.1.3 - Torque Specifications (General)

1.1.4 - Torque Specifications (Special)

1.1.5 - Sectional View

1.1.6 - Engine Specifications

Section 1.2 - WIRING DIAGRAMS

Section 1.3 - SPECIAL TOOLS

SECTION 1.1 SPECIFICATIONS

1.1.1-MODEL NUMBERS

Model No.	MC-35 6894	MC-35 6895	MC-38 6938	MC-38 6939	MC-40 6896	MC-40 6897
Wattage Capacity	3500	3500	3800	3800	4000	4000
Voltage	120*	120*	120*	120*	120*	120*
Maximum Amperes	29.2 at 120 V.		31.7 at 120 V.		33.3 at 120 V.	
Phase	1-Phase	1-Phase	1-Phase	1-Phase	1-Phase	1-Phase
Frequency	60 Hertz at 3600 rpm					
Voltage Regulation	Solid state voltage regulator maintains 120 Volts AC ($\pm 2\%$) at 60 Hertz					
Battery Charge	0-10 Amperes at 12 Volts DC					
Gross Weight (wet)	Approximately 127 pounds					
Engine Part No.	48078	48078	48078	48078	48078	48078
Bore	78 mm					
Stroke	62 mm					
Displacement	296 cc					
Governed Speed	3720 rpm at no-load					
Ignition System	Solid State					
Starting System	12 Volt DC electric (Ring Gear)					
Cranking Current	Approximately 90 Amperes					
Average Fuel Consumption	Approximately 0.70 Gallons per Hour					
Type of Fuel Pump	Mech.	Elec.	Mech.	Elec.	Mech.	Elec.

*Factory connected for 120 Volt AC output only. Unit is reconnectable to provide dual voltage output.

1.1.2-FUELS AND OILS

RECOMMENDED FUEL

Use NON-LEADED gasoline. Leaded REGULAR grade gasoline is an acceptable substitute. Do not use any highly leaded, premium gasoline.

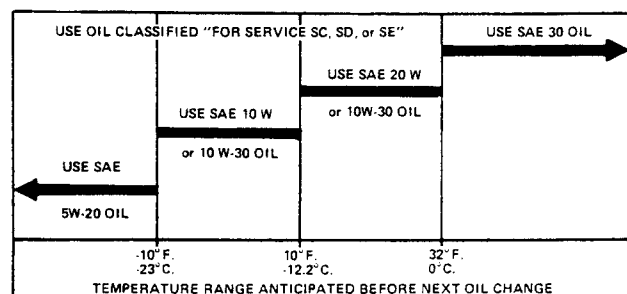

RECOMMENDED OIL

Use oil classified "For Service SC, SD or SE", as shown in the CHART at right.



1.1.3- TORQUE SPECIFICATIONS (GENERAL)

STANDARD TORQUE VALUES	All Values in FOOT-POUNDS TORQUE VALUES + 5 PER CENT							
	Grade 2		Grade 5		Grade 7		Grade 8	
BOLT SIZE	DRY	LUB	DRY	LUB	DRY	LUB	DRY	LUB
1/4-20	5	4	8	6	10	8	12	9
1/4-28	6	5	10	7	12	9	14	11
5/16-18	11	8	17	13	21	16	24	18
5/16-24	13	10	19	15	24	18	27	21
3/8-16	20	15	31	24	38	29	44	34
3/8-24	23	17	35	27	43	33	49	38
7/16-14	32	25	49	38	61	47	70	54
7/16-20	36	27	55	42	68	52	78	60
1/2-13	49	38	75	58	93	72	105	82
1/2-20	55	42	85	65	105	80	120	90
9/16-12	70	54	110	84	135	105	155	120
9/16-18	78	60	120	93	150	115	170	132
5/8-11	92	71	150	115	185	145	210	165
5/8-18	105	81	170	130	210	160	240	185
3/4-10	165	125	270	205	330	250	375	290
3/4-16	180	140	295	230	365	280	420	320
7/8-9	200	155	395	305	530	405	605	455
7/8-14	225	170	435	335	585	450	670	515
1 - 8	300	230	590	455	795	610	905	695
1 - 14	340	260	680	510				

GRADE	2	5	8
BOLT HEAD SYMBOL			

1.1.4- TORQUE SPECIFICATIONS (SPECIAL)

	INCH-POUNDS	FOOT-POUNDS
Spark Plug	216-264	18-22
Cylinder Head Bolts	264-348	22-29
Connecting Rod Cap Bolts	216-264	18-22
Engine Gear Cover Bolts	90-110	7.5-9
Blower Fan (Special M14 Hex Nut)	600-660	50-55
Rotor Bolt	180-200	15-17
Mechanical Fuel Pump Bolts	25-30	-----

1.1.5- SECTIONAL VIEW

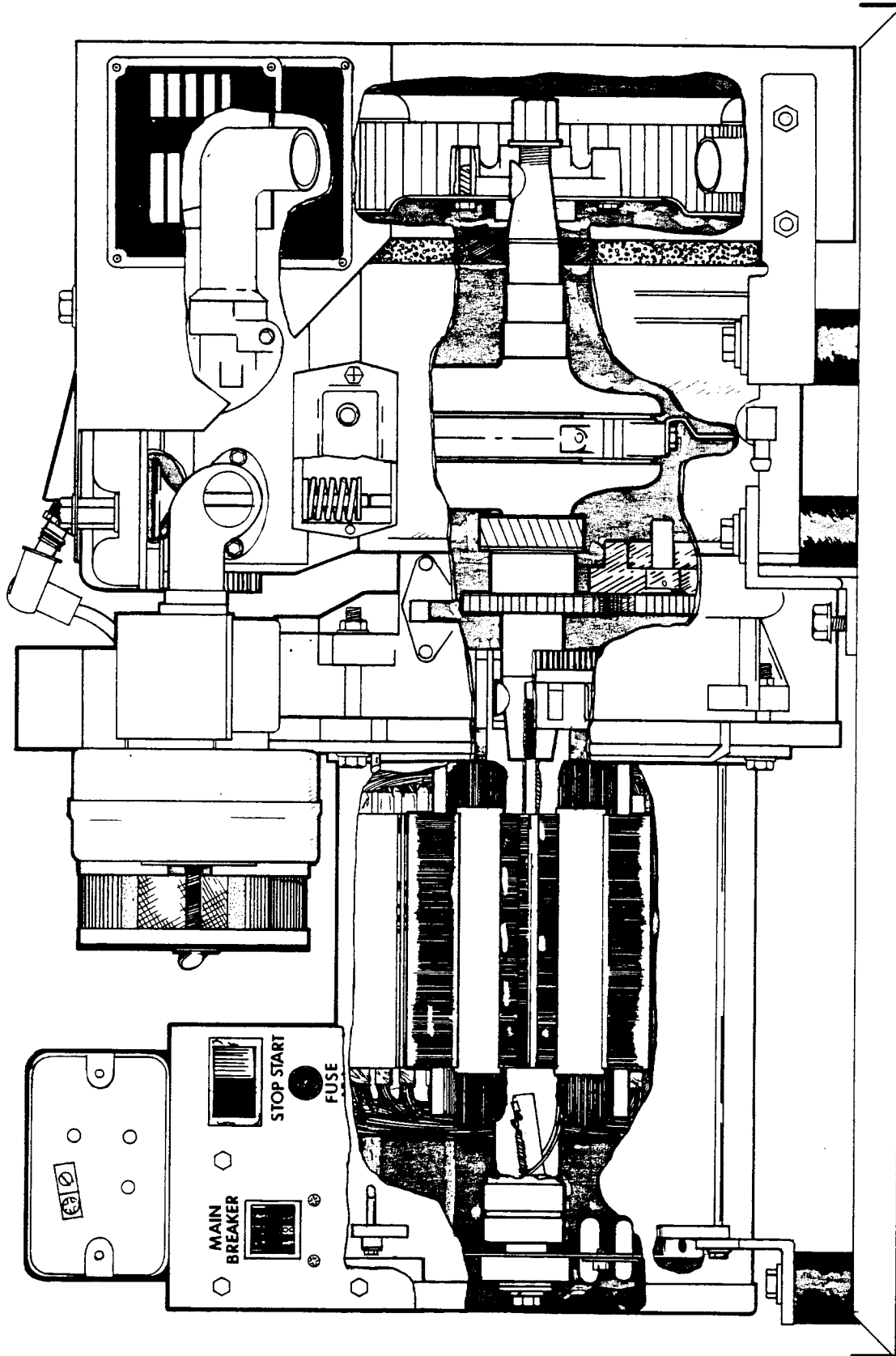

1.1.6- ENGINE SPECIFICATIONS

	INCHES	METRIC
Spark Plug Gap	0.035	0.009 mm
Valve Spring Length	1.2995	33.000 mm
Valve Spring Compression Length	1.0236	26.000 mm
Valve Seat Width	0.039- 0.079	1 - 2 mm
Valve Tappet Clearance	0.0039- 0.0078	0.1-0.2 mm
Crankshaft End Play	0.0039- 0.0118	0.1-0.3 mm
Piston Diameter (at skirt)	3.067- 3.068	77.91- 77.93 mm
Piston Pin Diameter	0.7080- 0.7086	17.989 mm- 18.000 mm
Width of Compression Grooves	0.0797- 0.0805	2.025 mm- 2.045 mm
Width of Oil Ring Groove	0.1584- 0.1593	4.025 mm- 4.045 mm
Width of Compression Rings	0.0775- 0.0784	1.970 mm- 1.990 mm
Width of Oil Ring	0.1560- 0.1570	3.970 mm- 3.990 mm
Ring End Gap	0.0078- 0.0157	0.2 - 0.4 mm
Maximum Permissible Out-of-Roundness of Crankpin	0.002	0.05 mm
Connecting Rod to Crankpin Clearance	0.001- 0.002	0.030- 0.050 mm
Valve Spring Force	14.81- 19.76 lbs	kilograms 6.72-8.96

WIRING DIAGRAMS

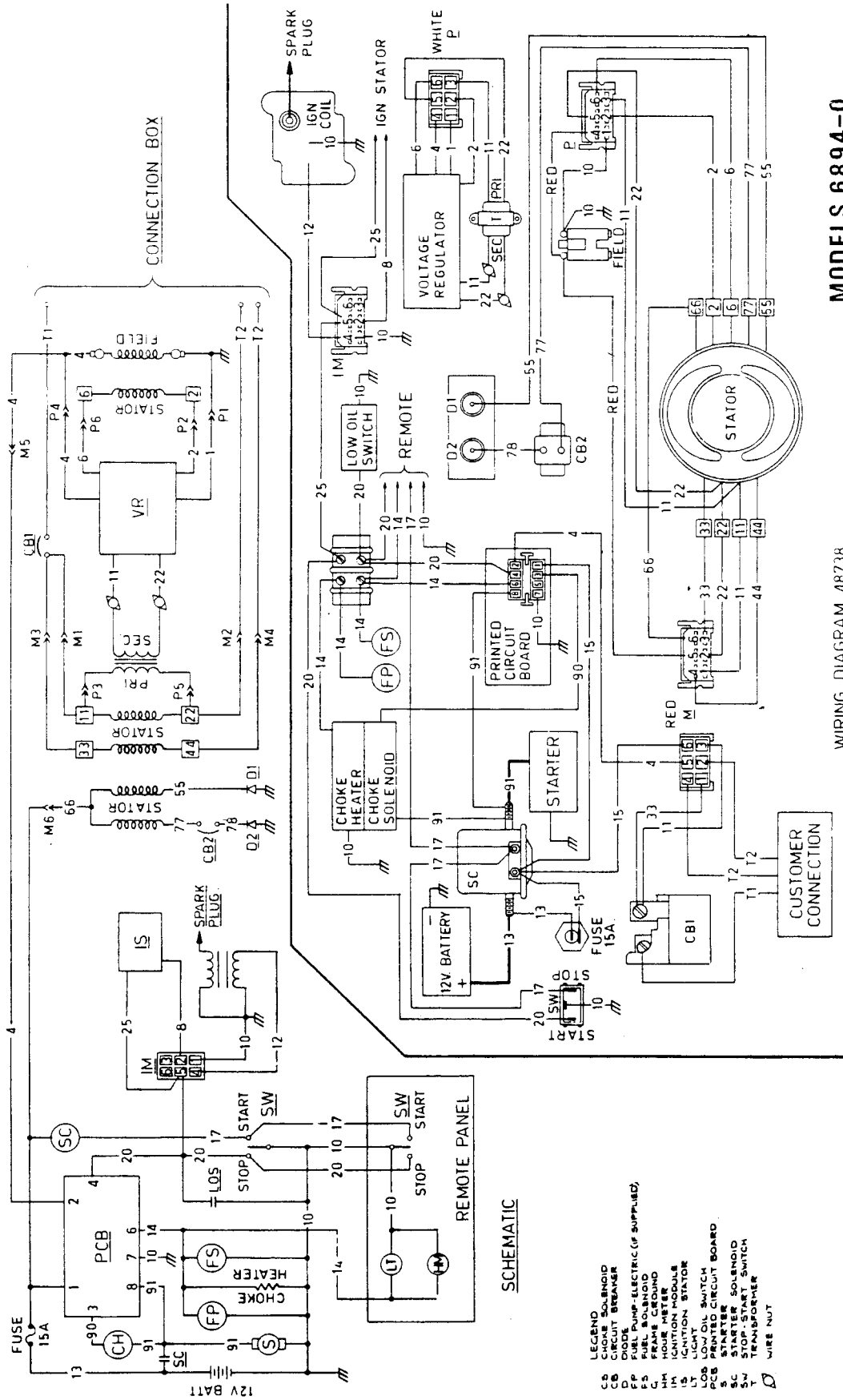

MODELS 6894-0
6895-0
6896-0
6897-0

WIRING DIAGRAM 48738

CONQUEST INC.

- LEGEND**
- CB CHoke SOLENOID
 - CB1 CIRCUIT BREAKER
 - D DIODE
 - FP FUEL PUMP-ELECTRIC (IF SUPPLIED)
 - FS FRAME GROUND
 - HC HOUR METER
 - HM HOUR METER
 - IM IGNITION MODULE
 - IS IGNITION STATOR
 - LOS LOW OIL SWITCH
 - PCB PRINTED CIRCUIT BOARD
 - S STARTER SOLENOID
 - SW STOP-START SWITCH
 - T TRANSFORMER
 - W WIRE NUT

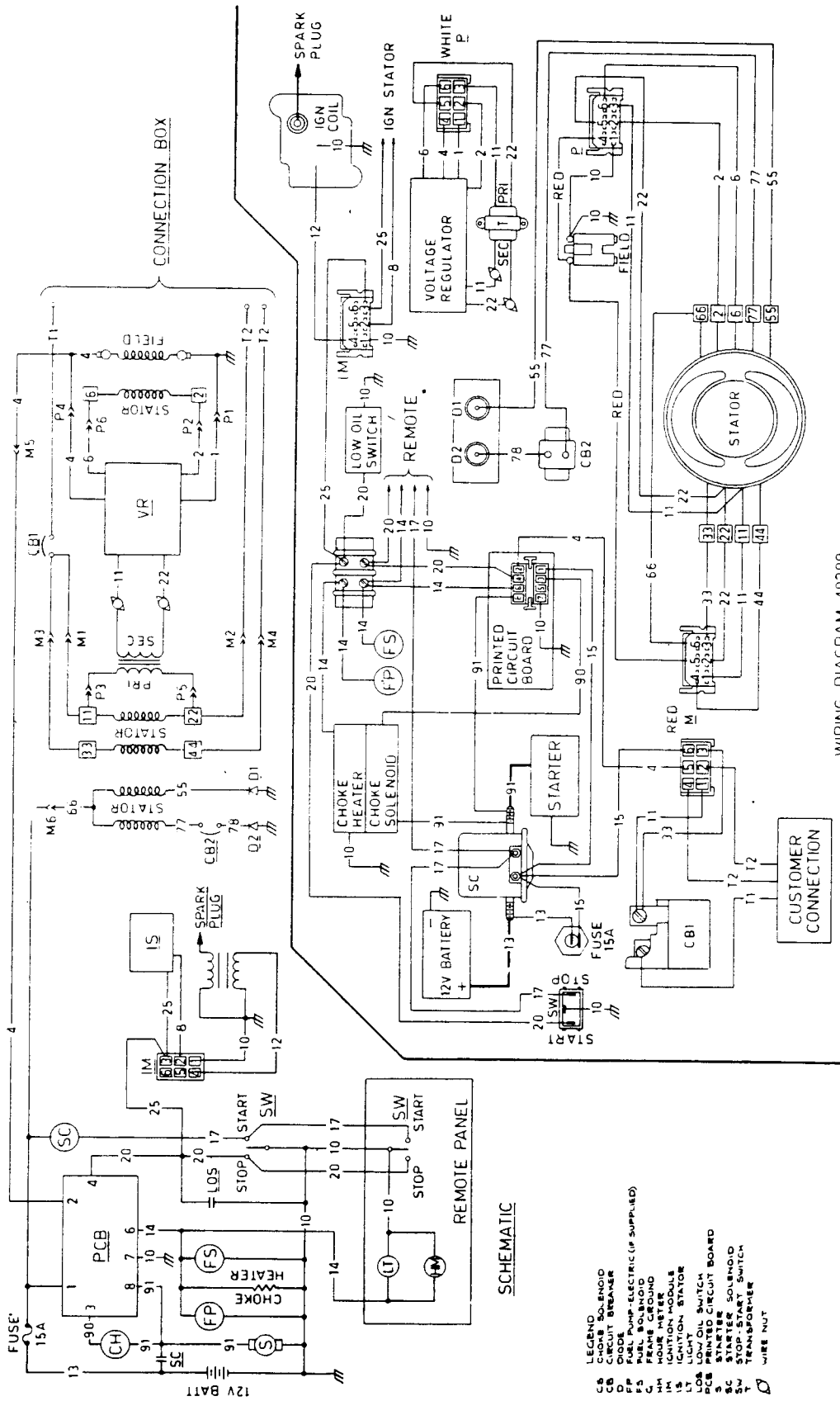

SCHMATIC

- LEGEND**
- CB CHOKE SOLENOID
 - CB CIRCUIT BREAKER
 - CH CHOKES
 - CP COILS (IMP-ELECTRIC (IF SUPPLIED))
 - FS FUSE
 - FP FUEL SOLENOID
 - FR FRAME GROUND
 - HM HOUR METER
 - IM IGNITION METER
 - IS IGNITION SWITCH
 - LT LIGHT
 - LS LOW OIL SWITCH
 - PCB PRINTED CIRCUIT BOARD
 - SC STARTER SOLENOID
 - SW STOP-START SWITCH
 - T TRANSFORMER
 - W WIRE NUT

WIRING DIAGRAM 49209

MODELS 6894-1,-2

6895-1,-2

6896-1,-2

6897-1,-2,-3

6938-0

6939-0

MODEL 8209-1

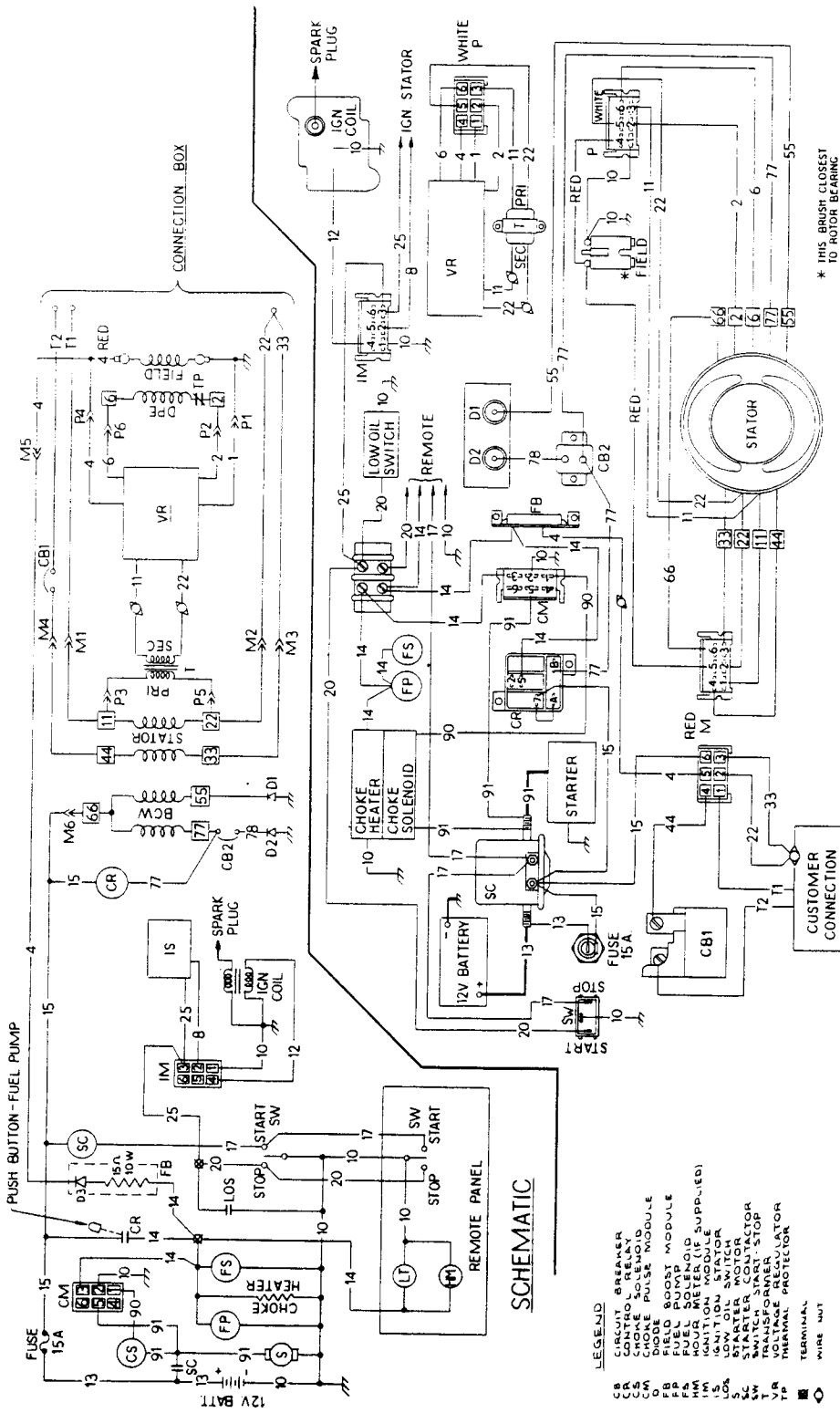

WIRING DIAGRAM

52130

ISSUED 1-3-75

MODEL 6897-4

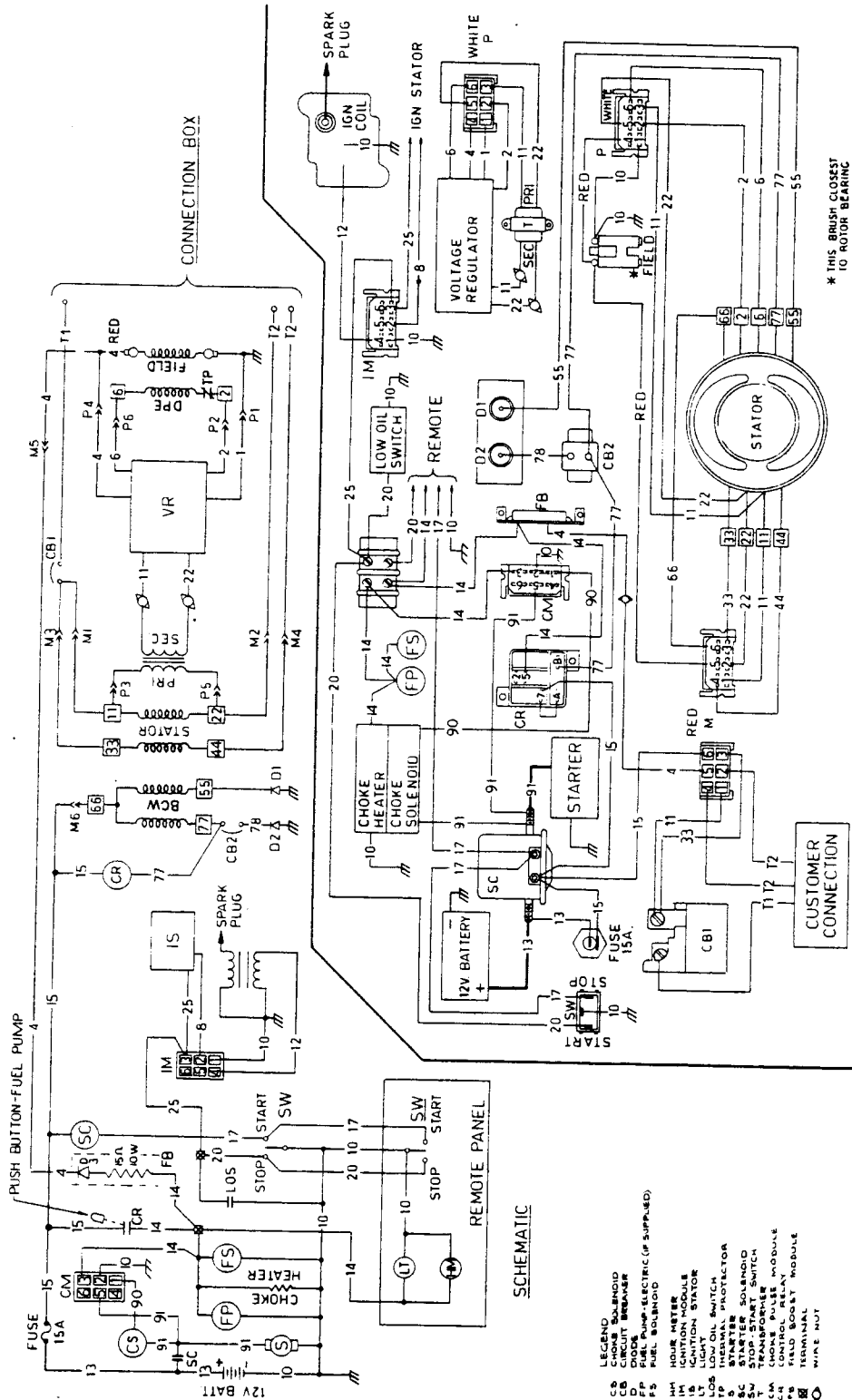

WIRING DIAGRAM

52124

* THIS BRUSH CLOSEST TO ROTOR BEARING

SCHEMATIC

- LEGEND
- CB CIRCUIT BREAKER
 - CR DIODE
 - CS CONDENSER
 - FP FUEL PUMP
 - FS FUEL SOLENOID
 - IM HOUR METER
 - IM1 IGNITION MODULE
 - IS IGNITION SWITCH
 - LOS LOW OIL SWITCH
 - LP THERMAL PROTECTOR
 - SC STARTER-SOLENOID
 - SW STOP-START SWITCH
 - CM COMPASSER MODULE
 - CR CONTROL RELAY
 - FB FIELDBOOST MODULE
 - FS FUEL SOLENOID
 - IM HOUR METER
 - IM1 IGNITION MODULE
 - IS IGNITION SWITCH
 - LOS LOW OIL SWITCH
 - LP THERMAL PROTECTOR
 - SC STARTER-SOLENOID
 - SW STOP-START SWITCH
 - CM COMPASSER MODULE
 - CR CONTROL RELAY
 - FB FIELDBOOST MODULE
 - FS FUEL SOLENOID

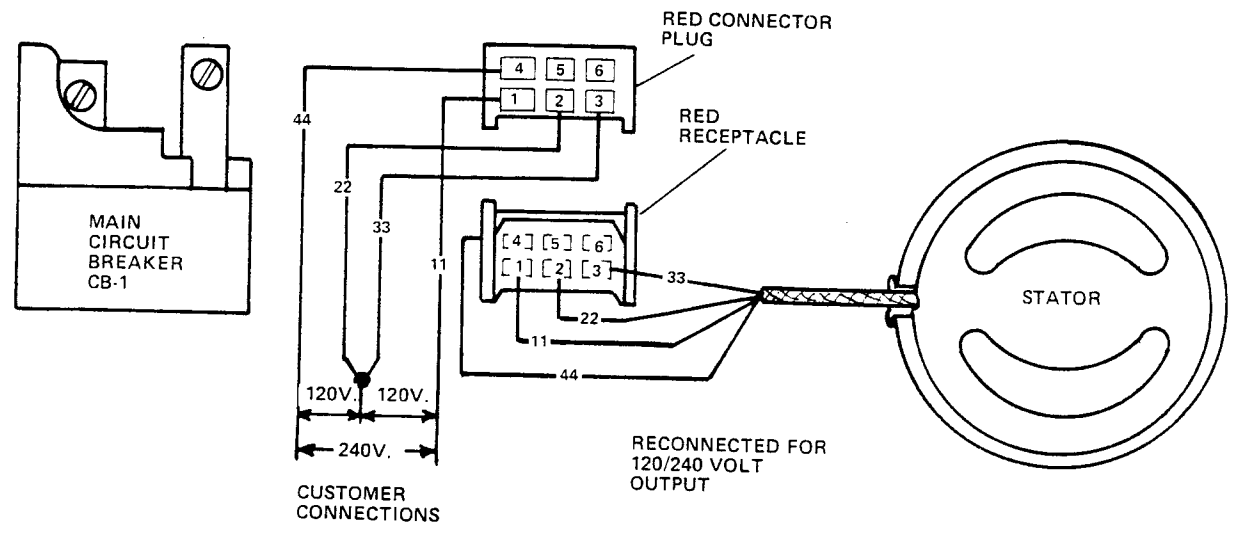
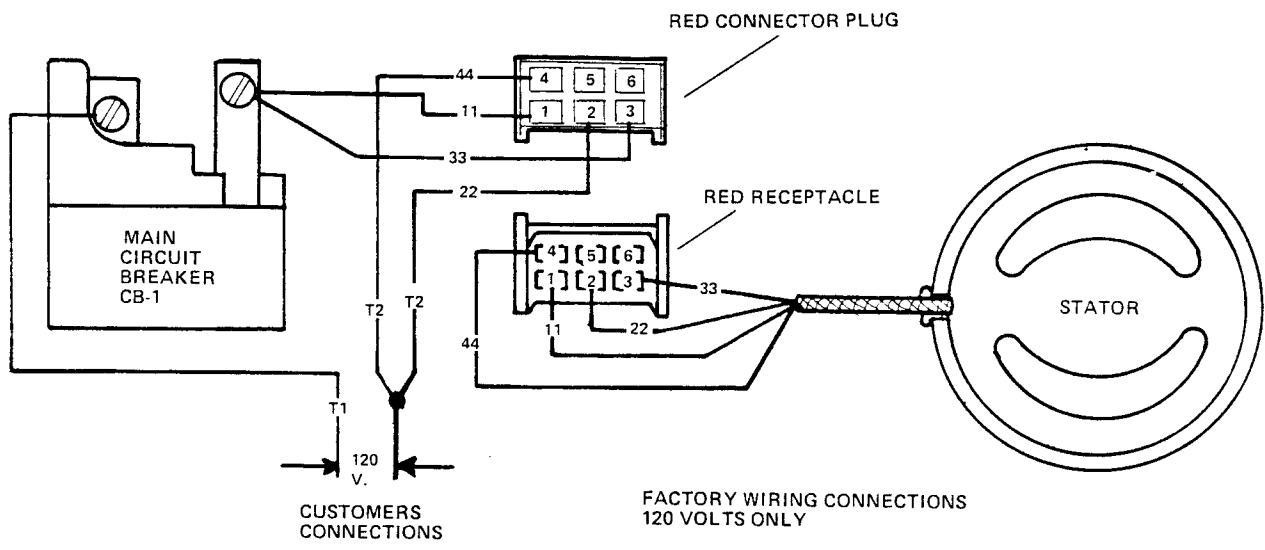

SECTION 1.3 SPECIAL TOOLS

ELECTRICAL TEST PLUG

The Electrical Test Plug facilitates the testing of electrical components in circuits that pass through the red and white stator can receptacles, or through the Ignition Module receptacle. Use the Test Plug in any diagnostic test that calls for connection of the VOM test probes to pins in these receptacles. Order Part No. 27069.

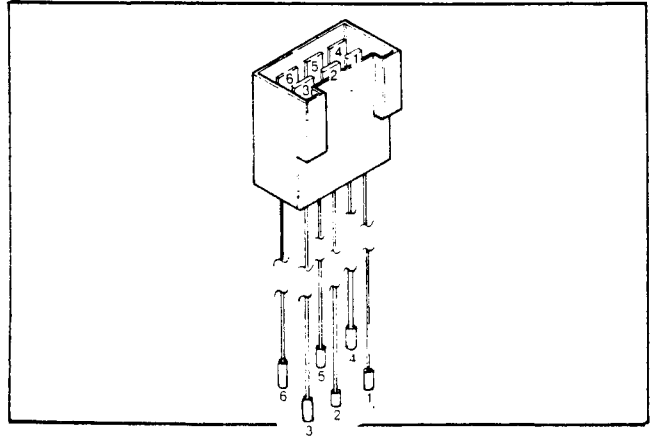

INSULATION BREAKDOWN TESTER

Resistance testing of alternator components with an Ohmmeter is generally valid. Such resistance tests will nearly always indicate the presence of an open or shorted condition. However, some malfunctions do not become evident until an electrical load is applied across the defective component. The insulation breakdown tester permits a component to be tested under a simulated load condition, by applying a selected voltage to the component. Follow the tester manufacturer's instructions strictly when using the tester.

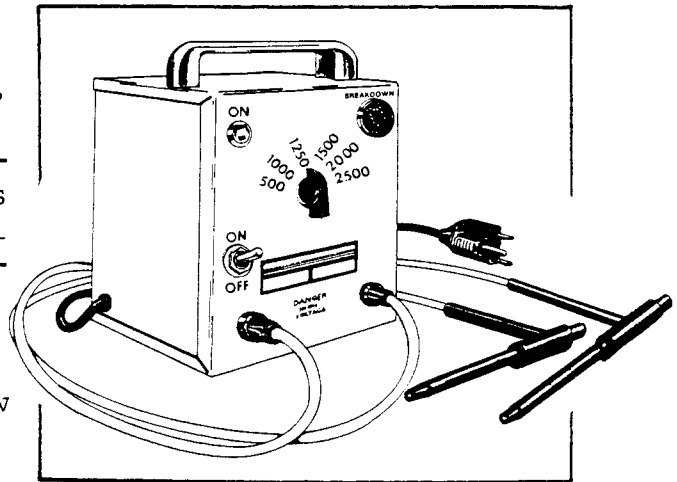

SPARK TESTER

The Spark Tester is used to check for proper ignition spark with the engine cranking. Order Part No. 41503.

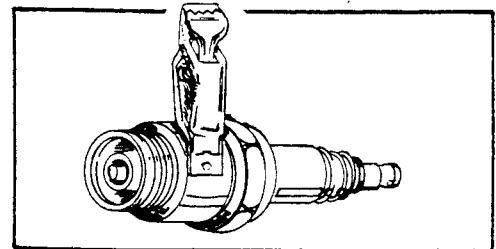

ROTOR REMOVAL KIT

The Rotor Removal Kit consists of a 3/8-24 TAP, 3/8-24 BOLT, and threaded studs of varying lengths. The kit is used for removal of the rotor. Order Part No. 41079.

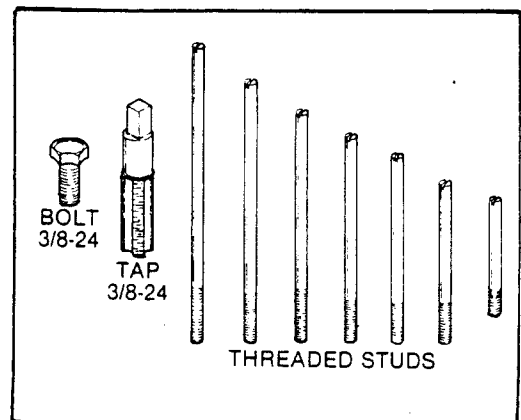

LOAD BANK

The Load Bank is used to apply an electrical load to alternators. The unit is equipped with a Voltmeter, Ammeter and Frequency Meter, as well as the necessary switches for selecting the desired load. Specify Model No. 5515.

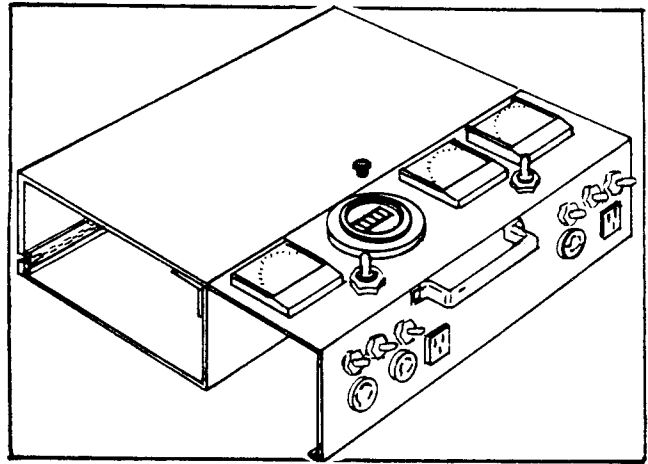

PART II

TROUBLE DIAGNOSIS

Section 2.1 - DIAGNOSTIC FLOW CHARTS

2.1.1 - Introduction

Engine won't Crank

Engine Cranks, won't Start

Engine starts hard - Runs Rough

Switch set to STOP - Engine Keeps Running

AC Voltage Low

AC Power Low

AC Voltage High

No AC Voltage

Section 2.2 - Diagnostic Tests

Section 2.3 - Battery Charge Circuit Tests

SECTION 2.1

DIAGNOSTIC FLOW CHARTS

2.1.1-INTRODUCTION

The DIAGNOSTIC FLOW CHARTS that follow are intended for use with the DIAGNOSTIC TESTS in Section 2.2. Test numbers assigned in the FLOW CHART are identical to the numbers assigned to specific tests in Section 2.2.

ENGINE WON'T CRANK

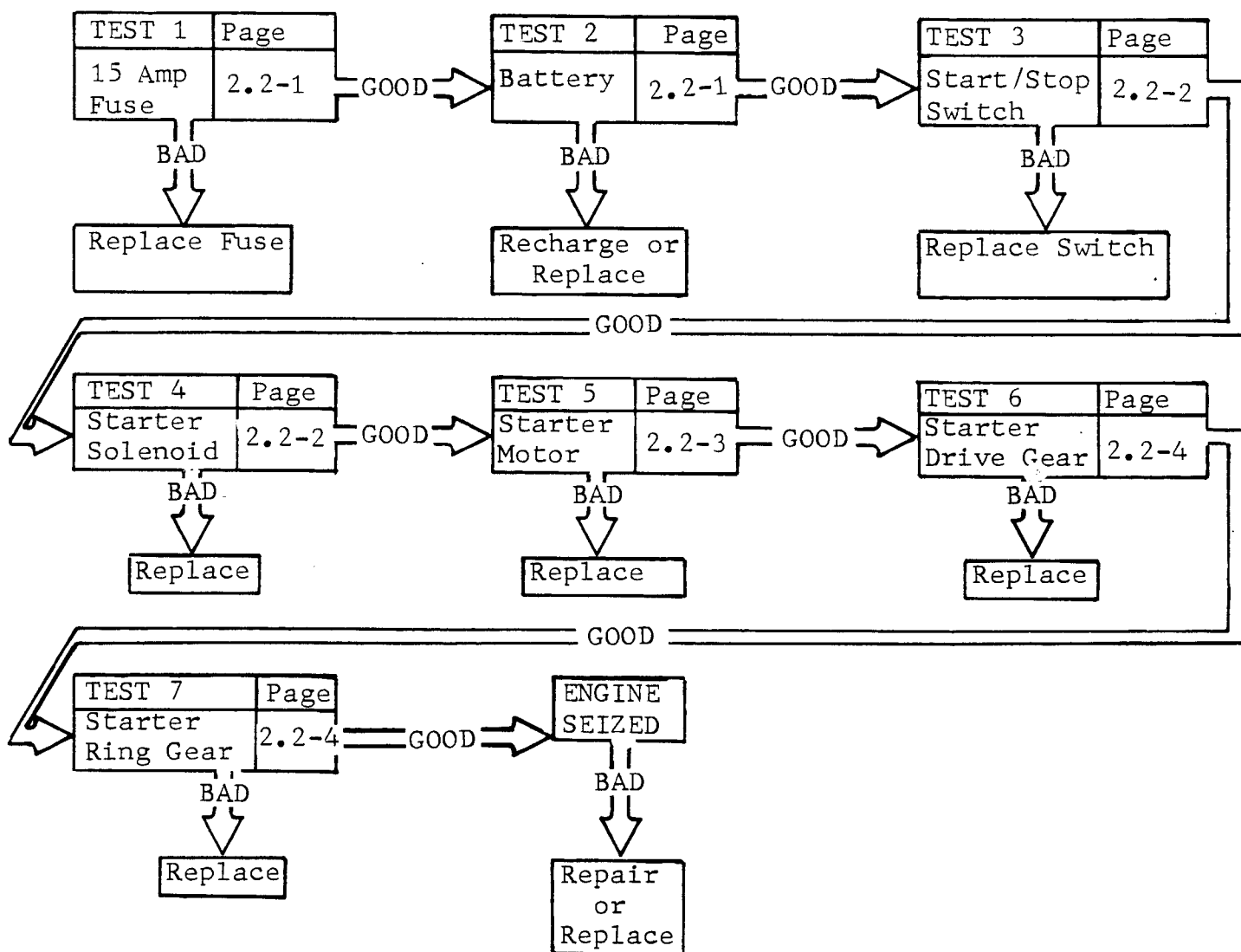

ENGINE CRANKS, WON'T START

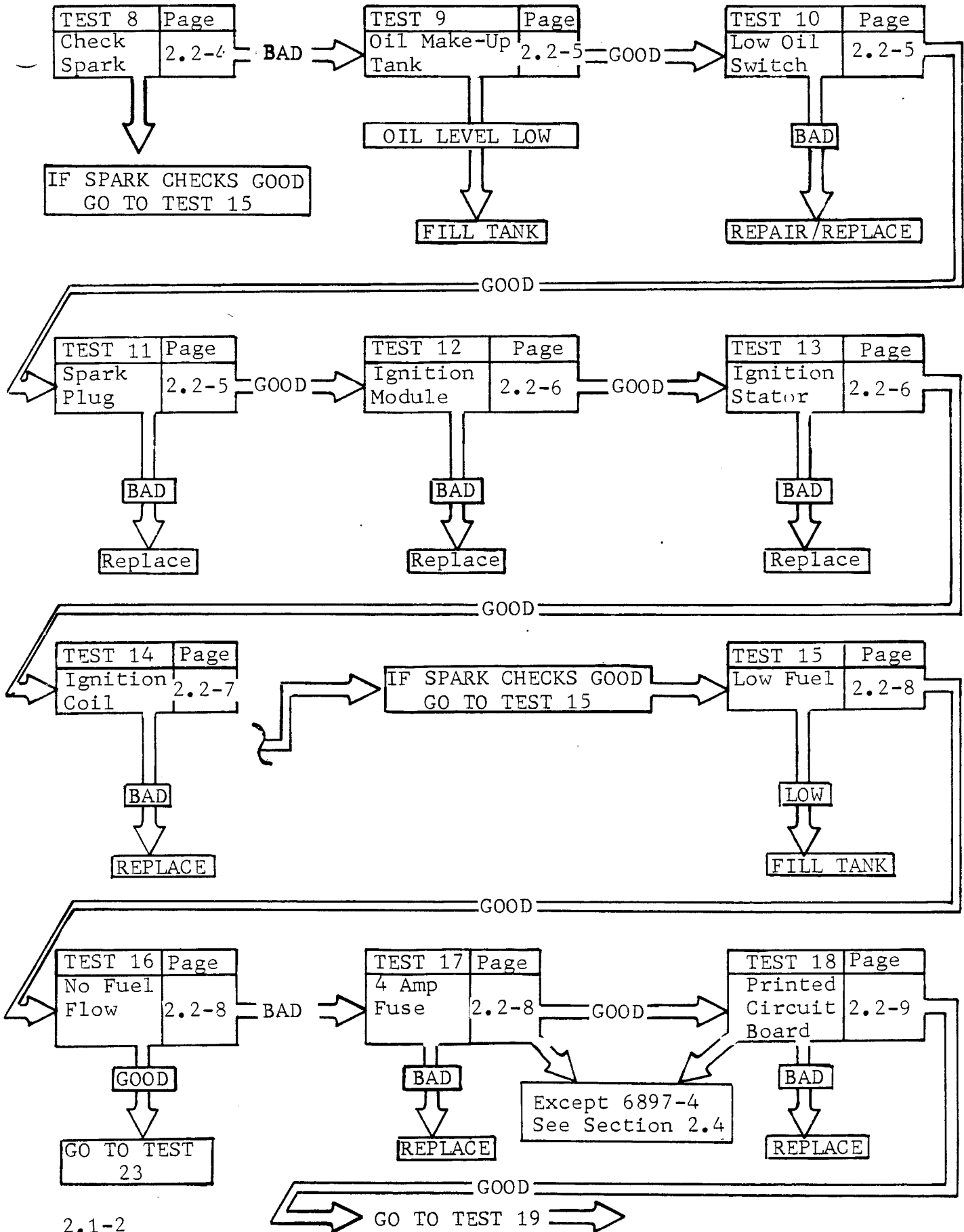

TEST 19	Page
Fuel Filter	2.2-9

TEST 20	Page
Fuel Lock-Off Solenoid	2.2-10

TEST 21	Page
Fuel Pump	2.2-10

BAD
↓
REPLACE

BAD
↓
REPLACE

BAD
↓
REPLACE

GOOD →

GOOD →

GOOD →

TEST 22	Page
Check Installation	2.2-11

IF FUEL FLOW IS GOOD
GO TO TEST 23

TEST 23	Page
Carburetor	2.2-11

TEST 24	Page
Compression	2.2-13

NO CHANGE →

ADJUST JETS → TEST → BAD → REPLACE CARBURETOR → TEST

GOOD
↓
GO TO TEST 29

CHECK FLOAT SEAT → BAD → REPLACE SEAT → TEST

TEST 25	Page
Head Gasket	2.2-13

GOOD →

TEST 26	Page
Valves	2.2-14

CHECK FLOAT LEVEL → BAD → ADJUST FLOAT LEVEL → TEST

BAD
↓
REPLACE GASKET
↓
TEST

REPAIR
↓
TEST

GO TO TEST 27

IF COMPRESSION IS GOOD, GO TO TEST 29

TEST 27	Page
Rings	2.2-14

GOOD

TEST 28	Page
Cylinder	2.2-14

TEST 29	Page
Timing	2.2-14

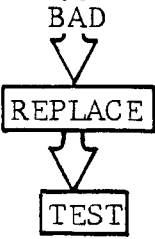

ENGINE STARTS HARD - RUNS ROUGH

TEST 8	Page
Check Spark	2.2-4

WEAK

TEST 12	Page
Ignition Module	2.2-6

WEAK

TEST 14	Page
Ignition Coil	2.2-7

TEST 11	Page
Spark Plug	2.2-5

BAD

REPLACE

BAD

REPLACE

GOOD

BAD

REPLACE

TEST 30	Page
Choke	2.2-15

GOOD

TEST 31	Page
Pre-Choke	2.2-16

GOOD

TEST 13	Page
Ignition Stator	2.2-6

BAD

REPLACE STATOR

Check Operation

BAD

Mechanical Movement

GOOD

Replace PCB

TEST

GOOD

TEST 15	Page
Low Fuel	2.2-8

LOW

FILL TANK

Adjust Linkage

6897-4:-Replace Choke Pulse Module. See Section 2.4

IF GOOD GO TO TEST 16

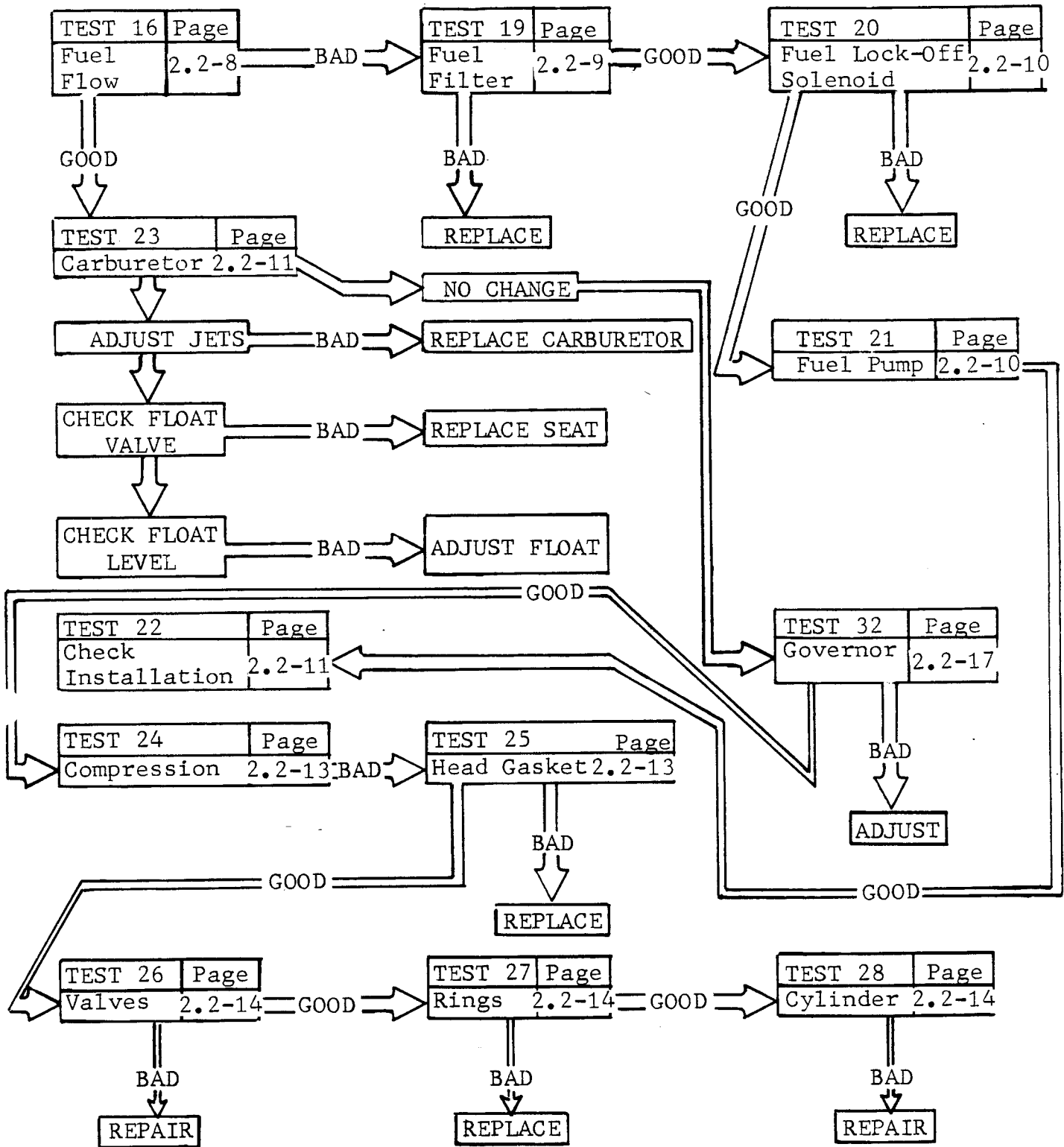

SWITCH SET TO STOP - ENGINE KEEPS RUNNING

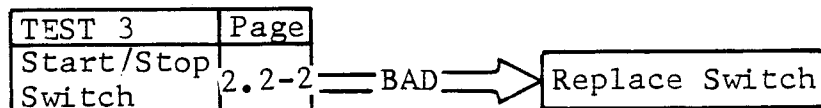

A-C VOLTAGE LOW

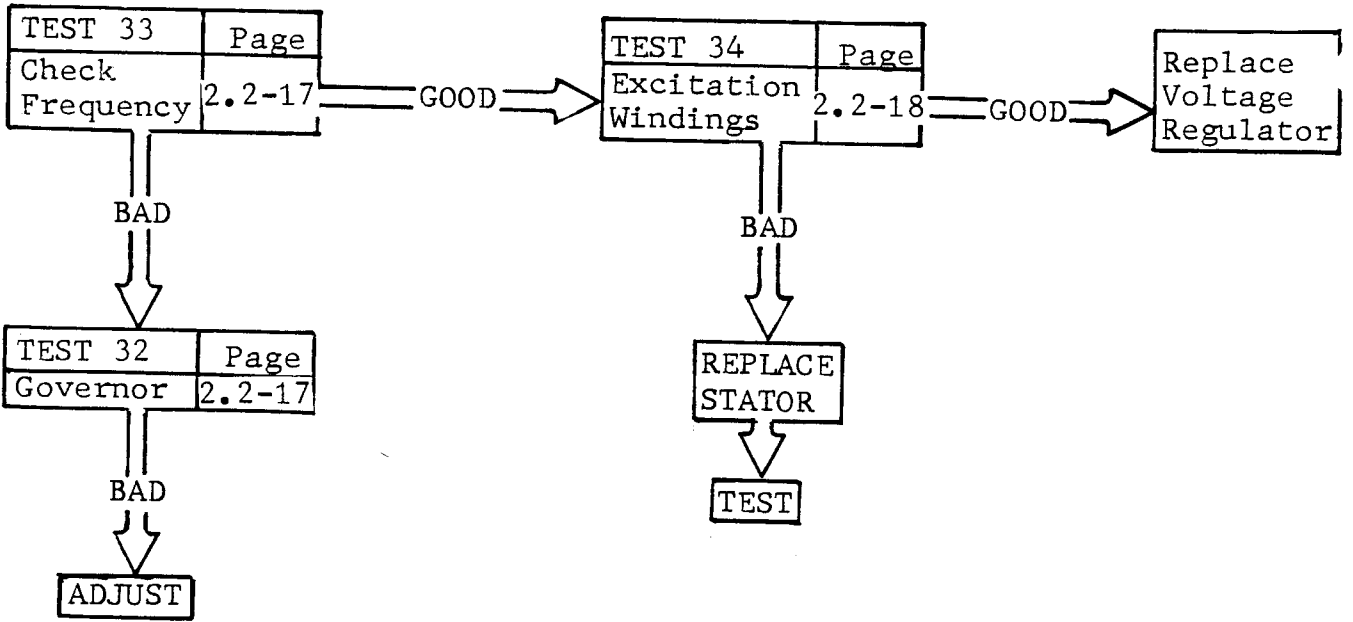

A-C POWER LOW

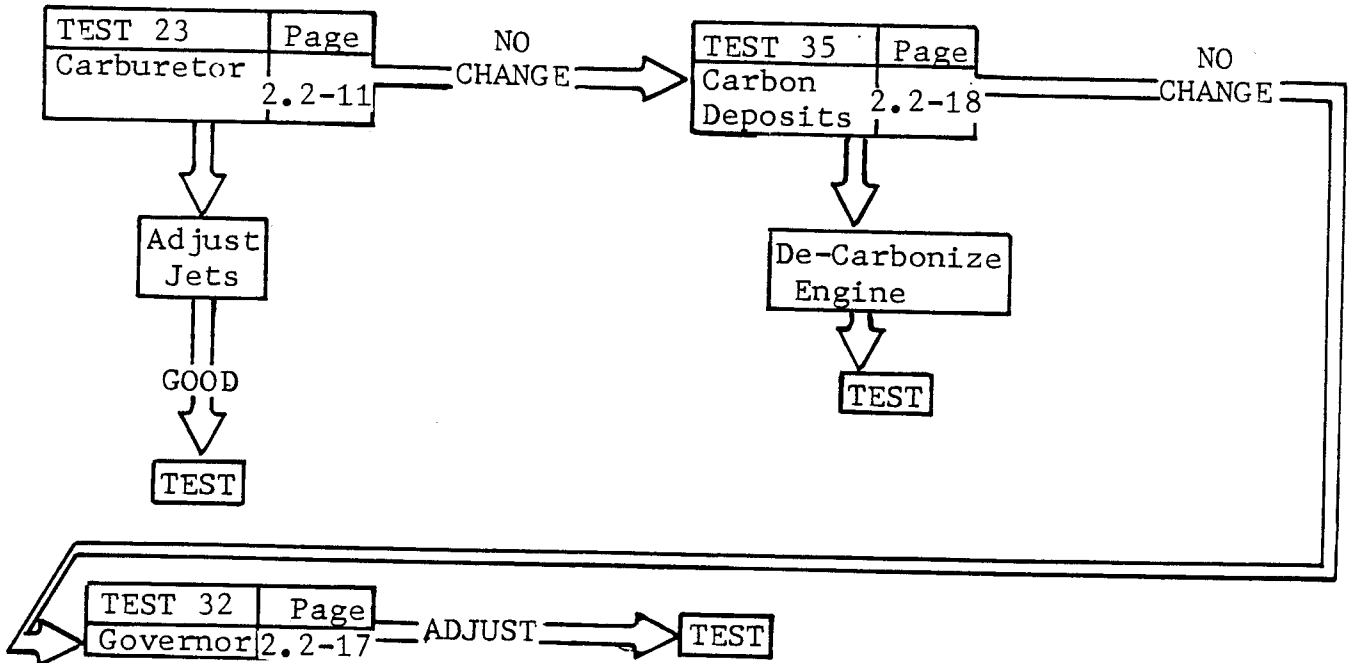

A-C VOLTAGE HIGH

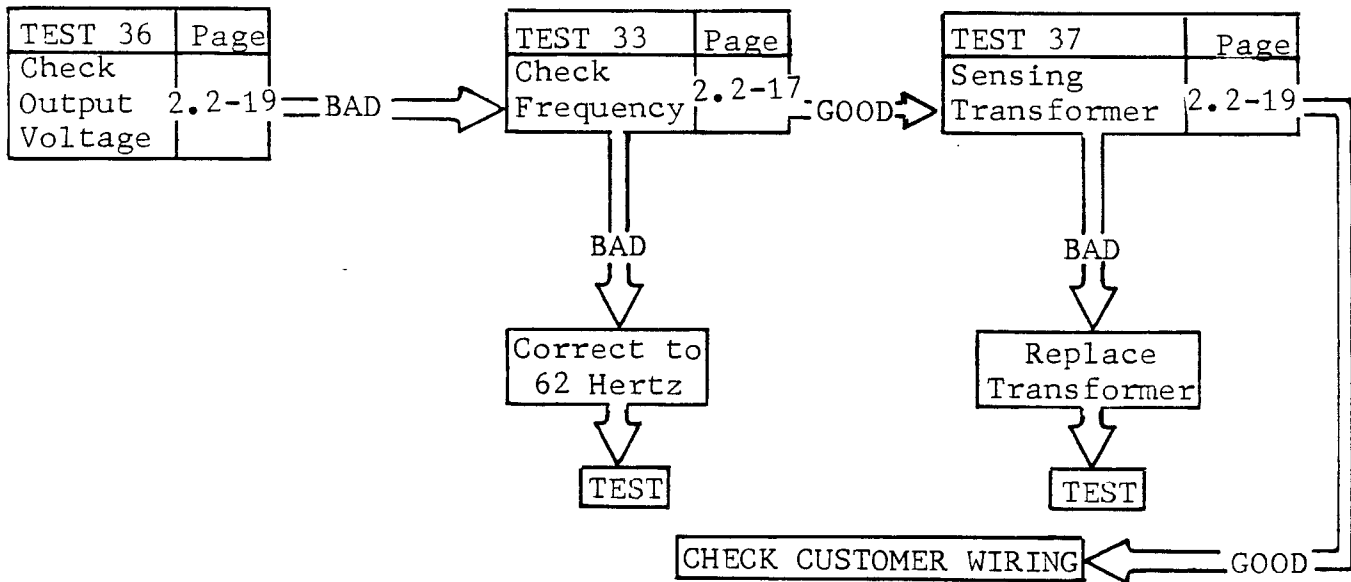

NO A-C VOLTAGE

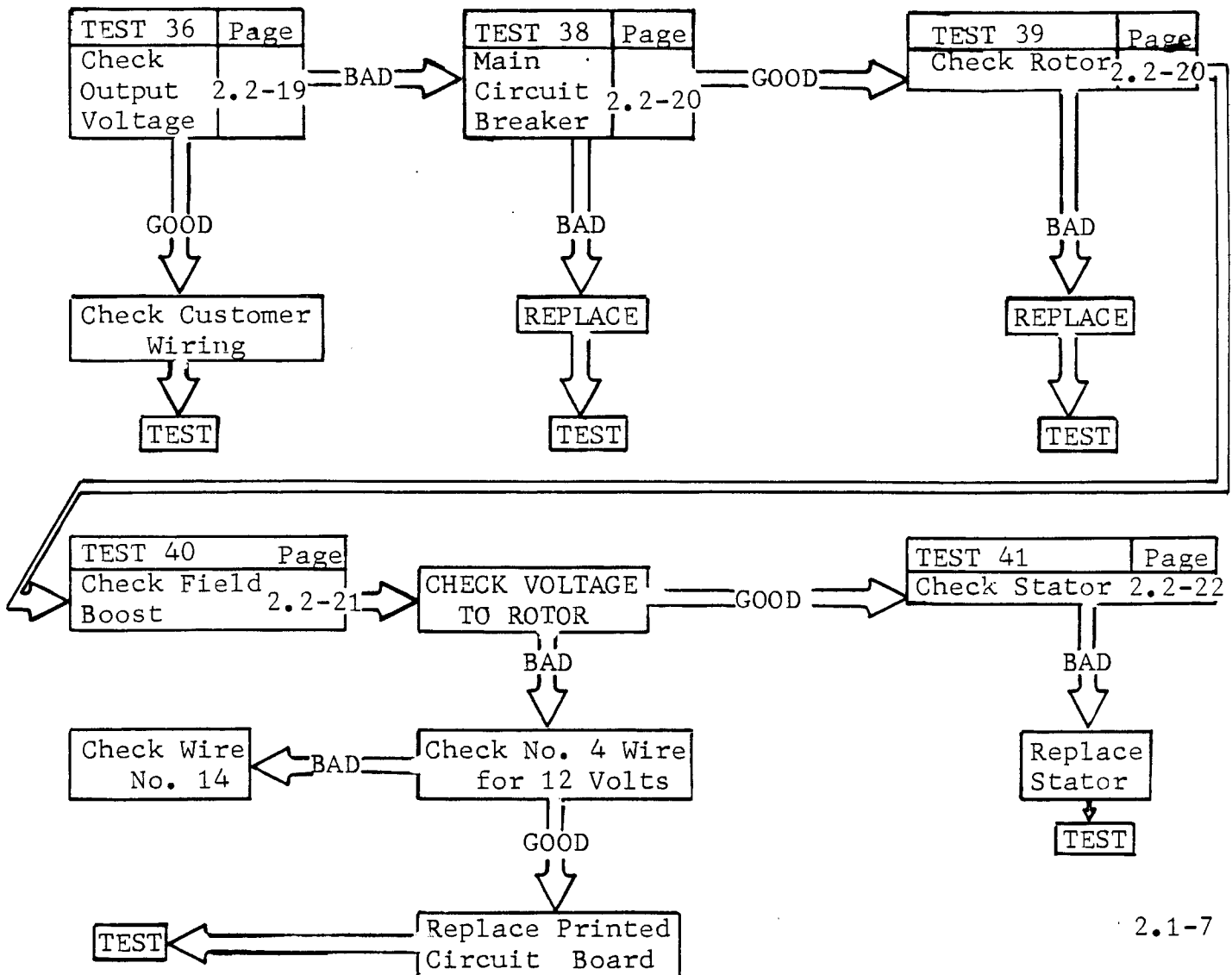

DIAGNOSTIC TESTS

TEST 1-15 AMP FUSE

Remove and visually inspect the 15 Amp Fuse. Replace, if Fuse element has melted. A more thorough check may be made with a Volt-Ohm-Milli-ammeter, as follows:-

- 1.)-Set VOM to "+DC" and to "Rx1" scale.
- 2.)-Connect meter test probes and "Zero" the meter.
- 3.)-Connect meter test probes to Fuse ends. Meter needle should swing upscale to "0" ohms (continuity). If meter needle does not move upscale, replace the Fuse.

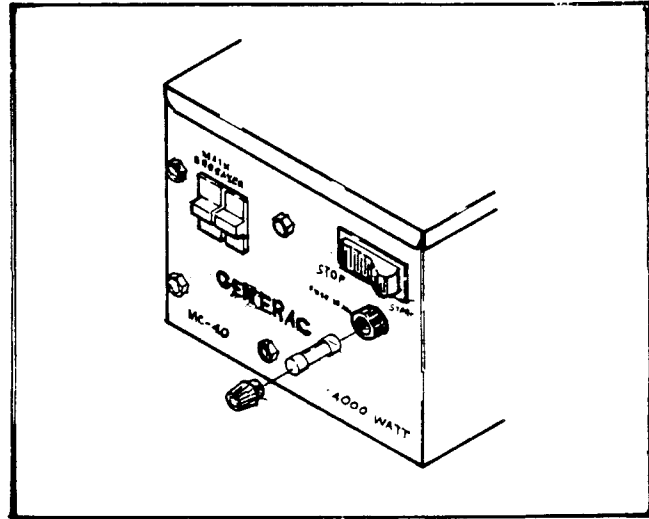

RESULTS:-Fuse tests bad.....Install new 15 Amp Fuse
 Fuse tests good.....Continue tests

TEST 2-BATTERY

Check Battery condition, as well as the condition, cleanliness and security of battery cables and connections.

RESULTS:-Battery, cables or connections.....Recharge or replace defective Battery. Repair, clean or replace defective cables or connection
 check bad
 Battery, cables or connections.....Continue tests
 check good

TEST 3-STOP/START SWITCH

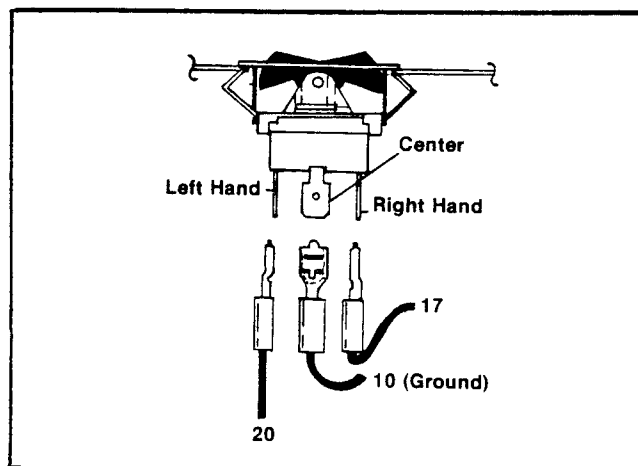
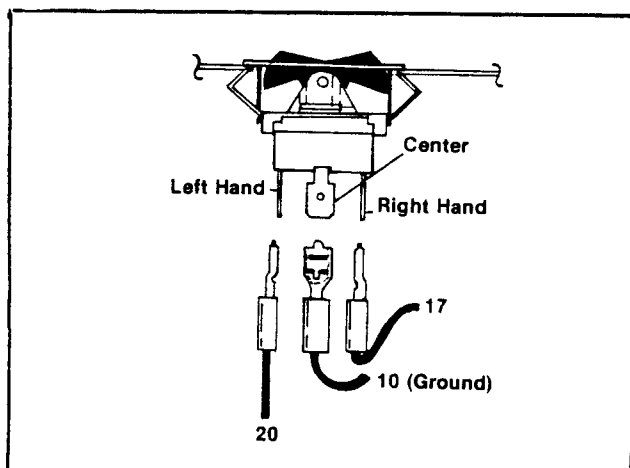

Remove 15 Amp Fuse to disconnect starting circuit. Remove panel top cover. Disconnect wires from switch terminals to prevent interaction. Set VOM to "+DC" and to "Rx1" scale, then zero the meter. Connect meter test probes to the switch center and right hand terminals (as viewed from switch rear). Meter needle should not move. Hold Switch at START - meter

Connect VOM test probes to Switch center and left terminals (as viewed from switch rear). Hold the Switch at START - meter needle should not move. Release the Switch to NEUTRAL - meter needle should not move. Hold the Switch at STOP - needle should swing upscale to "0".

-Install new Stop/Start Switch
-Connect Switch wires, install top panel and 15 Amp Fuse. Continue tests.

A.)- Set Stop/Start Switch to START and back to NEUTRAL several times. An audible "click" should be heard as the solenoid actuates.

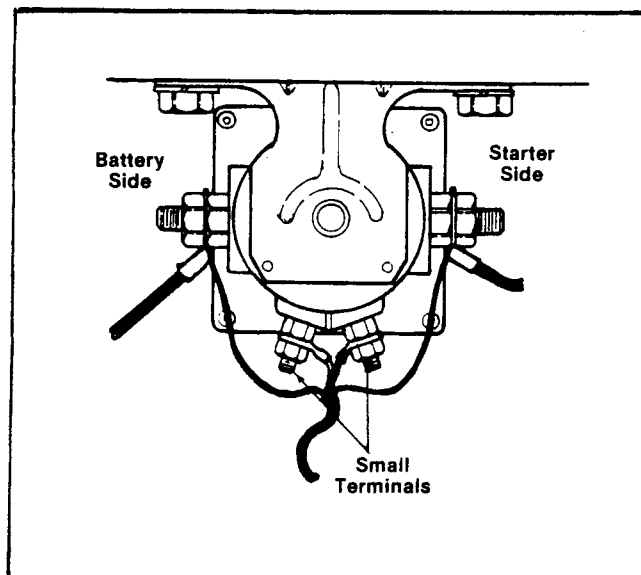

RESULTS:- Solenoid actuates, engine
does not crank.....Continue tests in Paragraph B
Solenoid does not actuate.....Continue tests in Paragraph D

B.)- Set VOM to "+DC" and to a scale greater than 12 Volts DC. Connect the NEGATIVE (COMMON) test probe to ground. Connect the POSITIVE (+) probe to the battery cable connection on the solenoid. Meter should indicate approximately 12 Volts DC.

RESULTS:- Meter reads 12 Volts DC.....Continue tests in Paragraph C
Meter reads less than 12.....Check for open or shorted wire
Volts DC (or loose connection) between
Battery and Starter Solenoid

C.)- Connect POSITIVE (+) meter test probe to starter cable connection on solenoid. Connect NEGATIVE (COMMON) probe to ground. Hold Stop/Start Switch at START - meter should indicate approximately 12 Volts DC.

RESULTS:- Meter does not read
12 Volts DC.....Install new Starter Solenoid
Meter reads 12 Volts and.....Continue tests in DIAGNOSTIC
Solenoid checks good FLOW CHARTS

D.)- Set VOM to "+DC" and to a scale greater than 12 Volts. Connect the meter POSITIVE (+) test probe to one of the small terminals on the solenoid. Connect the remaining probe to ground. Meter needle should read approximately 12 Volts DC. With one probe still connected to ground, connect the remaining terminal to the other small terminal on the solenoid - meter should indicate approximately 12 Volts DC.

RESULTS:- Meter indicates 12 Volts.....Continue tests
Meter does NOT read 12 Volts..Repeat Tests 1, 2 and 3. When
sure that these tests are good
and 12 Volts is not indicated
in Test 4.D., replace solenoid

TEST 5- STARTER MOTOR

Set VOM to "+DC" and to a scale greater than 12 Volts DC. Connect VOM positive (+) test probe to the Starter terminal lug and COMMON (-) test probe to frame ground. Hold Stop/Start switch at START. Meter should indicate approximately 12 Volts DC and starter motor should run.

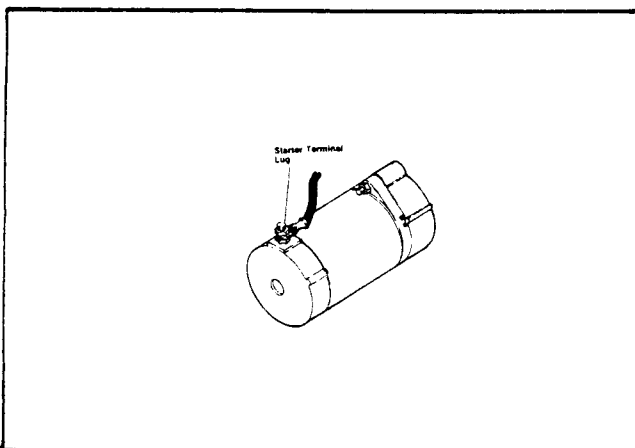

RESULTS:- Meter indicates 12 Volts DC,
Starter runs.....Continue tests
Meter indicates 12 Volts DC,
Starter does not run.....Replace Starter
Meter does not indicate 12 Volts.....Check Starter cable

TEST 6- STARTER DRIVE GEAR

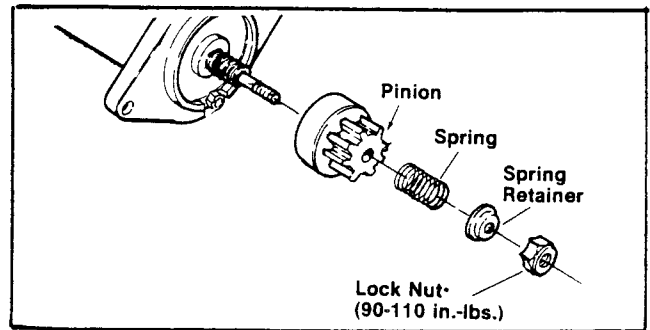
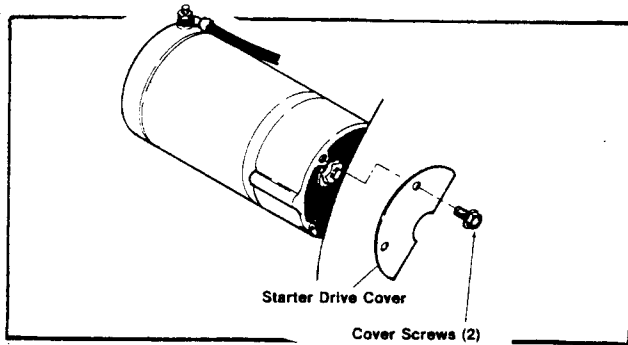

A.)-Hold Stop/Start switch at its START position and listen for the starter motor. If motor runs freely (without load), remove Starter drive cover.

B.)-Visually check Starter pinion for damage. if damaged, replace pinion.

C.)-To replace Starter pinion assembly, remove lock nut, spring retainer, and pinion. Install a new pinion, spring, spring retainer and lock nut. Tighten lock nut to 90-110 inch-pounds. DO NOT LUBRICATE PINION SPLINES.

RESULTS:- Starter drive checks good.....Continue tests
 Starter drive is defective.....Replace

TEST 7- STARTER RING GEAR

Inspect Starter Ring Gear for damage. Ring Gear and Flywheel are heat shrunk onto Rotor assembly. If replacement is necessary, entire assembly must be replaced.

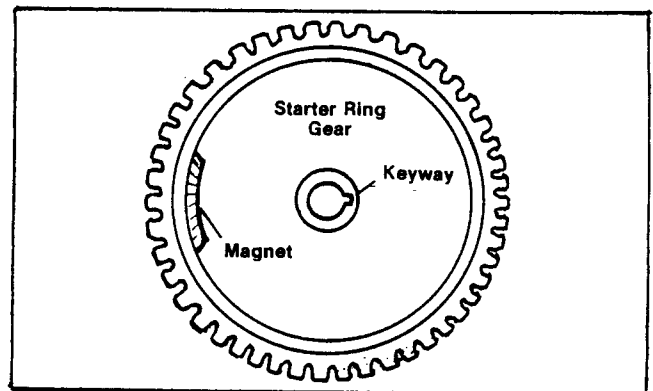

TEST 8- CHECK SPARK

Disconnect spark plug lead from engine spark plug and connect to Spark Tester (Part No. 41503). Connect Tester clamp to engine spark plug. Crank engine - spark tester should emit a blue, snappy spark.

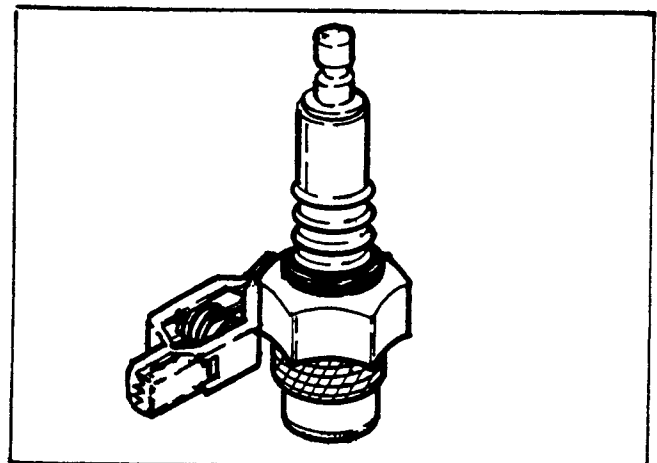

RESULTS:- Spark tests good.....
Go to Test 15
 Spark tests bad.....
Continue tests

TEST 9- OIL MAKE-UP TANK

Check oil level in Oil Make-Up Tank. If oil level is below OIL CHANGE LEVEL arrows, fill tank with recommended engine oil and recheck for proper start.

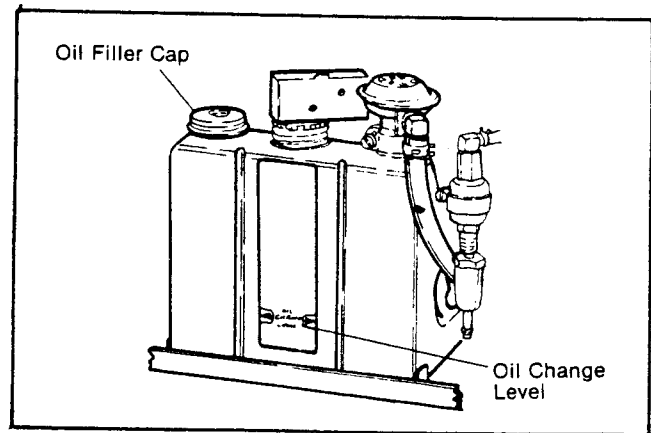

TEST 10- LOW OIL SWITCH

Remove Low Oil Switch Cover and slide it down the Switch wires to expose the Switch terminals. Set VOM to "+DC" and to "Rx1" scale, then zero the meter. Connect one meter test probe to the lower terminal on side of switch. Connect remaining test probe to ground terminal on bottom of the switch. Move switch actuating lever DOWN (simulated low oil condition) - meter needle should swing upscale to "0". Raise the switch actuating lever (FULL condition) - meter needle should drop downscale to infinity.

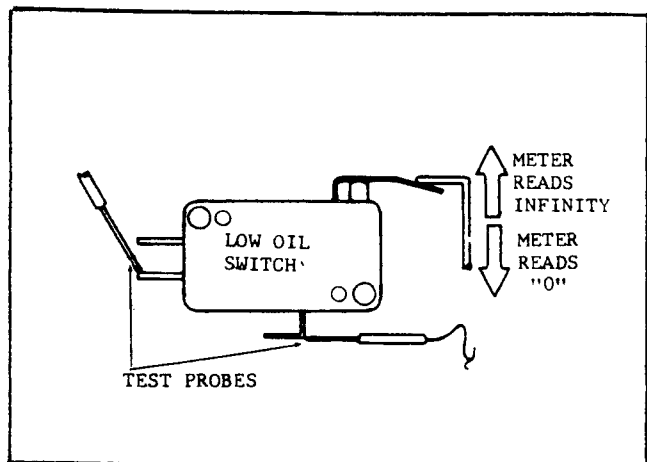

RESULTS:- Switch tests bad.....Replace switch
Switch tests good.....Continue tests

CAUTION

When reassembling Switch cover, make sure float arm is in place on top of switch actuating lever, or switch will not function.

TEST 11- SPARK PLUG

Remove engine spark plug. With spark plug lead connected to plug, ground the spark plug against the engine block and crank engine. Spark plug should emit a sharp, snappy, blue spark.

RESULTS:- Spark Plug tests bad.....Replace Spark Plug
Spark Plug checks good.....Continue tests

TEST 12- IGNITION MODULE

Unplug the Ignition Module from its receptacle on the side of the stator can. Carefully inspect module and receptacle pins for damage, bending or "pushing out" from their retainers. Plug in a known good "shop" module and check for normal sparking at the spark plug.

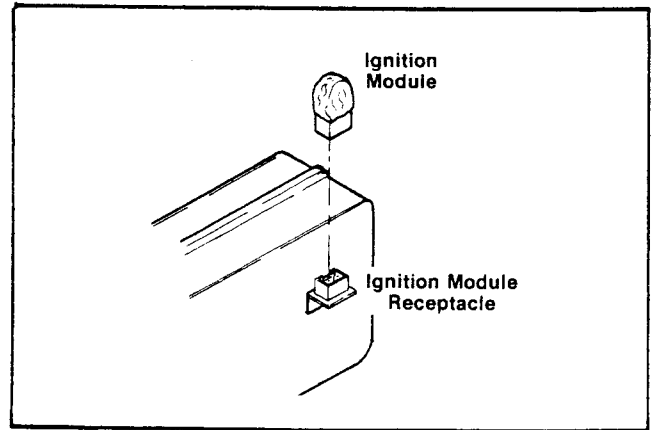

RESULTS:- Ignition Module tests good.....Continue tests
 Ignition Module tests bad.....Replace

TEST 13- IGNITION STATOR

A.)-Trigger Coil:- Set VOM to "+DC" and to "Rx1" scale. Zero the meter. On the DC Control Board, unplug the connector plug from its receptacle to prevent interaction. Also unplug the Ignition Module from its receptacle. Insert one meter test probe into Pin No. 3 of the Ignition Module Receptacle. Connect the remaining test probe to frame ground. The meter needle should swing upscale and read Trigger Coil resistance (about 7 Ohms).

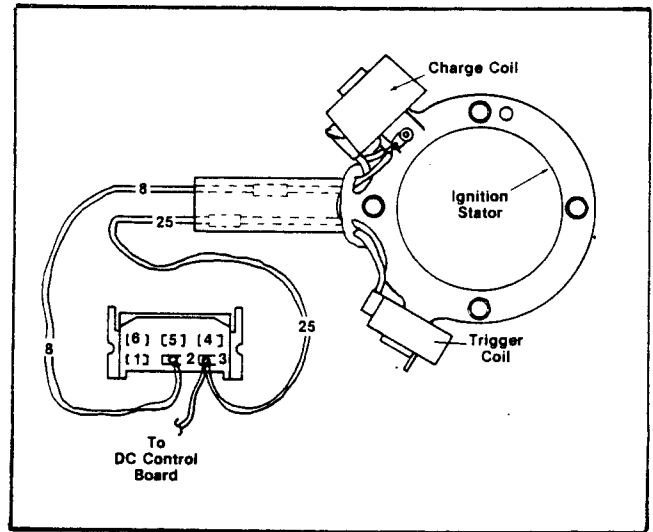

RESULTS:- Meter needle does not move.....Check Wire No. 25 between Ignition Module receptacle and Ignition Stator for an "open" condition. If Wire No. 25 is good, replace Ignition Stator

Meter needle swings upscale.....Continue checks and indicates approximately 7 Ohms resistance

B.)- Charge Coil:- Set VOM to "+DC" and to "Rx10" scale, then zero the meter. Insert one meter test probe into Pin No. 2 of the Ignition Module receptacle. Connect the remaining test probe to frame ground. The meter needle should swing upscale and indicate approximately 250 Ohms resistance.

RESULTS:- Meter needle does not move.....Check Wire No. 8, between Ignition Module receptacle and Ignition Stator Charge Coil for an "open" condition. If Wire No. 8 checks good, replace Ignition Stator.

Meter indicates approximately 250...Continue checks
Ohms

REINSTALL CONNECTOR PLUG INTO DC CONTROL BOARD RECEPTACLE AND IGNITION MODULE INTO ITS RECEPTACLE BEFORE CONTINUING.

TEST 14- IGNITION COIL

A.)- Primary Winding:- Set VOM to "Rx1" scale and to "+DC". Zero the meter. Connect the positive (+) test probe into Pin 4 of the Ignition Module receptacle. Connect the negative (common) test probe to frame ground. Meter needle should swing upscale to nearly "0".

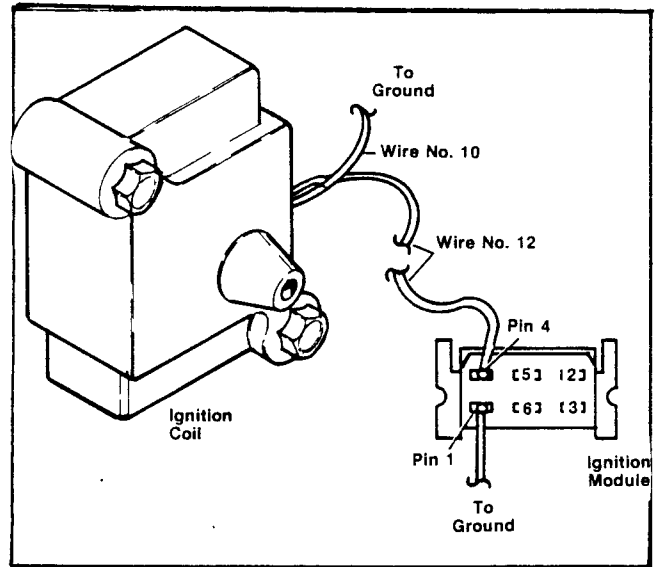

RESULT:- Meter needle does not move.....Replace Ignition Coil
Meter indicates nearly "0".....Continue test

B.)- Secondary winding:- Set VOM to "Rx1K" and to "+DC". Zero the meter. Install spark plug lead into Ignition Coil. Connect one meter test probe to spark plug end of spark plug lead and the remaining probe to frame ground. Meter needle should swing upscale and indicate approximately 5000 Ohms (+10%).

RESULT:- Meter needle does not move.....Check spark plug lead for open condition. If lead is good, replace Ignition Coil
Meter reads approximately.....Continue test
5000 Ohms



CAUTION
To prevent damage to Ignition Coil, make sure spark plug lead and spark plug are installed and grounded to engine before cranking.

TEST 15:- LOW FUEL

The motor home engine and the alternator engine should "share" the vehicle fuel tank, through a dual fuel pickup tube arrangement. See illustration at right. To prevent the alternator from depleting the fuel tank, the alternator fuel pickup tube is usually several inches shorter than the vehicle engine tube. Thus, the alternator may be "out-of-gas" while the vehicle engine has a sufficient fuel supply.

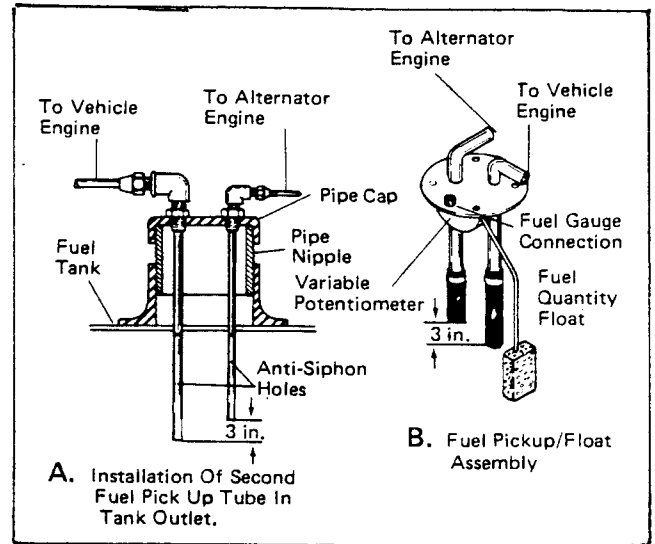

Make sure the alternator fuel supply line is NOT connected into the vehicle engine fuel supply line. If the vehicle engine is running, the alternator engine may be starved of fuel. When the vehicle engine is not running, the alternator may drain the vehicle engine fuel line (and even the vehicle engine carburetor). The latter will result in hard starting of the vehicle engine.

TEST 16:- NO FUEL FLOW

Disconnect fuel line at Carburetor inlet fitting. Place open end of fuel line into a suitable container, then crank engine. Fuel should pump from open end of fuel line. If little or no fuel comes from fuel line, check in-line filter for clogging. Replace fuel line and filter, if filter is clogged.

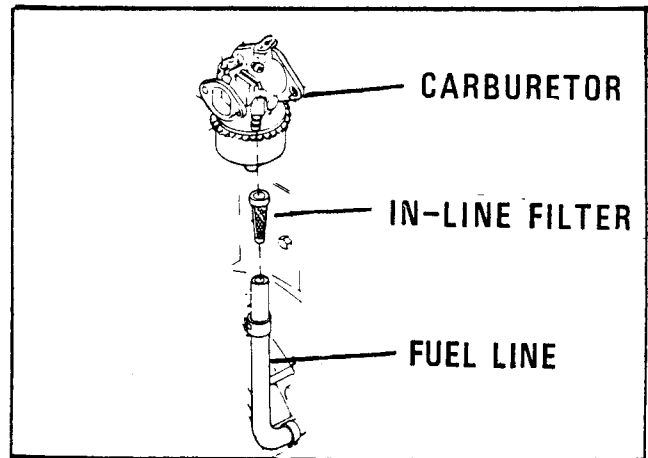

RESULTS:- Little or no fuel flow observed.....Continue tests
 Fuel flow is good.....Go to Test 23

TEST 17:- 4 AMP FUSE

The 4 Amp Fuse is equipped with a Fuse Puller Tab for easy removal. Remove the Fuse from the Printed Circuit Board and test in same manner as 15 Amp Fuse (Test 1). If Fuse is defective, replace. (NOTE:-Model 6897-4 has no 4 Amp Fuse. See Section 2.4.)

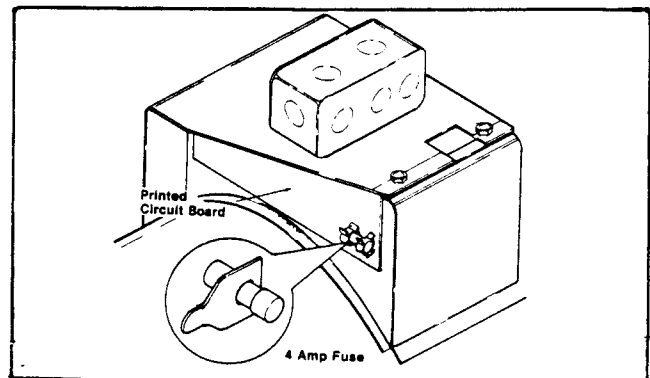

TEST 18:- PRINTED CIRCUIT BOARD

A.)- Depress Printed Circuit Board connector plug locking tangs and remove connector plug. On the connector plug, locate Pin 4 to which Wire No. 20 attaches. Set VOM to AC and to the 2.5 volt scale. Connect one meter test probe to connector plug Pin 4. Connect the other test probe to frame ground. Crank engine. Meter should indicate a small pulsing voltage. This is the pulsing voltage from the Ignition Stator trigger coil, which energizes circuit board components.

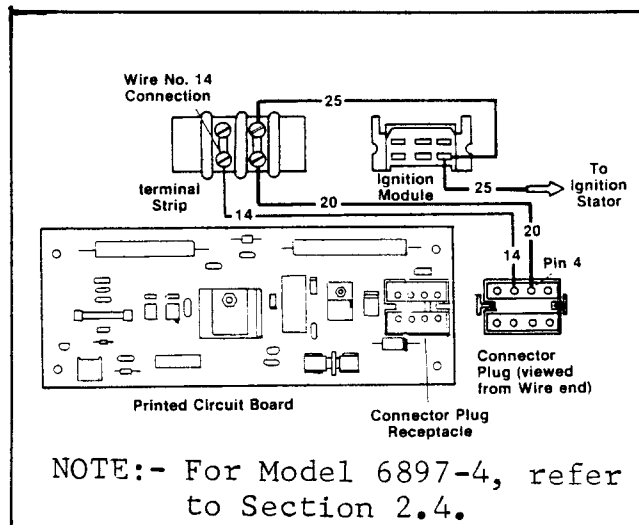

RESULTS:- Meter indicates pulsing voltage.....Continue tests
 No pulsing voltage indicated...Check Wire No. 20, between connector plug and terminal strip, and Wire No. 25 between terminal strip and Ignition module for open or shorted condition

See illustration above. Locate the Wire No. 14 connection at terminal strip. Plug the Printed Circuit Board connector plug into its receptacle. Set VOM to "+DC" and to "50V" scale. Connect positive (+) meter test probe to terminal strip Wire No. 14 connection. Connect remaining test probe to frame ground. Crank the engine. Meter should swing upscale and indicate 9-12 Volts DC.

RESULTS:- Meter indicated 9-12 Volts.....Continue tests in Diagnostic Flow Charts
 Meter did NOT read 9-12 Volts..Check Wire No. 14 (between PCB and terminal strip) for open or short. If wire is good, replace Circuit Board

TEST 19:- FUEL FILTER

Remove and replace fuel filter. Make sure arrow on filter body points toward the solenoid operated Fuel Shutoff Valve. Repeat Test 16 (NO FUEL FLOW).

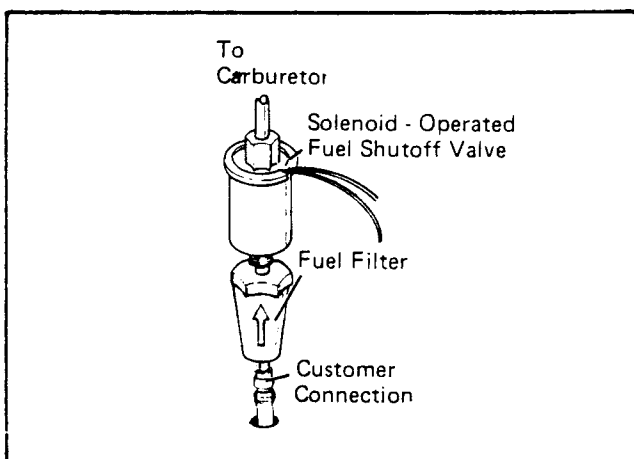

TEST 20:- FUEL LOCK-OFF SOLENOID

A.)- Locate Wire No. 14 between the Fuel Lock-Off Solenoid and terminal strip. Disconnect the wire at its terminal strip connection. Crank engine. While cranking, touch Wire No. 14 to its terminal strip connection. Fuel solenoid should actuate. If the unit has an electric fuel pump, a noticeable change in fuel pump sound will be detected.

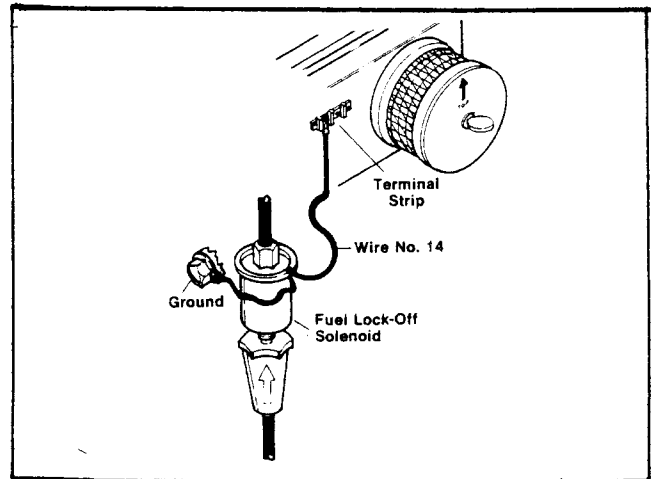

RESULT:- Solenoid did not actuate.....Go to Paragraph B
Solenoid actuates....Continue tests in DIAGNOSTIC FLOW CHARTS

B.)- Disconnect Fuel Lock-Off Solenoid Wire No. 14 at the terminal strip. Set VOM to "+DC" and to "Rx1" scale. Zero the meter. Connect one meter test probe to the terminal end of Wire No. 14. Connect the remaining test probe to frame ground. Meter needle should swing upscale to indicate resistance of solenoid windings.

RESULT:- Meter did not swing upscale....Check Wire No. 14 between solenoid and terminal strip for open condition. Also check the solenoid ground wire and connection

Meter needle swung upscale.....Replace Fuel Lock-Off Solenoid and solenoid did not actuate in Paragraph A

TEST 21:- FUEL PUMP

UNITS WITH ELECTRIC FUEL PUMP

A.)- Disconnect Wire No. 14 at the Fuel Pump. Set VOM to "+DC" and to "Rx1" scale. Zero the meter. Connect one meter test probe to the Fuel Pump Wire No. 14. Connect the remaining test probe to frame ground. Meter needle should swing upscale and indicate approximately 50 Ohms.

RESULT:- Pump tests good.....Go to Paragraph B
Pump tests bad.....Replace pump

C.)- Set VOM to "+DC" and to 50V scale. Disconnect Wire No. 14 at the Fuel Pump. Connect POSITIVE (+) meter test probe to terminal end of Wire No. 14. Connect COMMON test probe to frame ground. Crank the engine - meter needle should deflect upscale and read approximately 12 Volts DC (battery voltage).

RESULT:- Meter needle does NOT swing upscale.....Go to Paragraph C
Meter indicated approximately 12 Volts.....Replace Fuel Pump

C.)- Check Wire No. 14, between Fuel Pump and terminal strip, for open or shorted condition.

- RESULT:- Wire No. 14 checks good.....Continue Diagnostic tests
Wire No. 14 checks bad.....Repair/replace Wire No. 14

UNITS WITH MECHANICAL FUEL PUMP

Disconnect Pump Outlet Line at the carburetor inlet. Connect a pressure gauge to the line. Disconnect Pump Inlet Line at the fuel lock-off solenoid and immerse line in clean gasoline. Crank engine. The pressure gauge should indicate 1-3 psi.

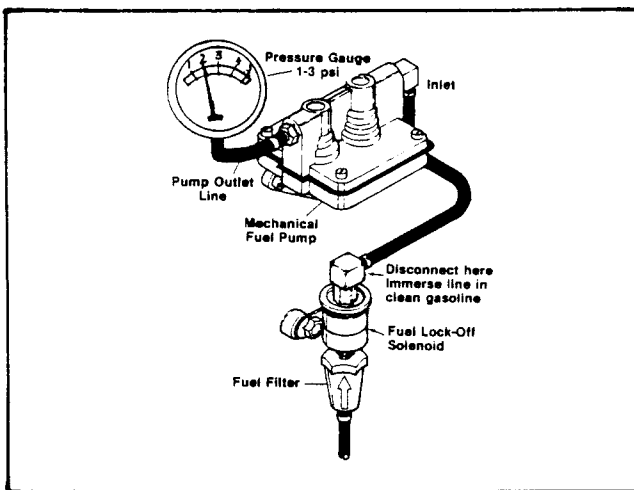

- RESULT:- Pressure gauge read 1-3 psi.....Continue Diagnostic Tests
Pressure gauge does not read 1-3 psi.....Replace Pump

TEST 22:- CHECK INSTALLATION

Check alternator installation for:-

- 1.)- Any other filter screens in the fuel supply line from gas tank. If other filters are found, check for clogging.
- 2.)- A Shutoff Valve in the fuel supply line. Make sure Shutoff Valve is OPEN.
- 3.)- Anything that might restrict cooling air flow, such as air inlet or exhaust openings too small, clogged air inlet screening, etc. If cooling air flow is inadequate, interior compartment temperatures will be high resulting in possible fuel line vapor lock.
- 4.)- Alternator fuel pump located too high above fuel supply tank. Maximum vertical lift for MC units with an electric pump is approximately 18 inches, for mechanical fuel pumps approximately 9 inches.

TEST 23- CARBURETOR

This test covers the procedures for adjustment of the carburetor Idle Speed Stop Screw, Idle Mixture Adjusting Screw, and High Speed Jet Adjusting Screw. In addition to these adjustments, the float valve and its seat should be checked, as well as the float level.

A.)-Turn High Speed Jet Adjusting Screw clockwise until it just bottoms. DO NOT USE EXCESSIVE FORCE. Then turn High Speed Jet Adjusting Screw counterclockwise about 1½ turns. Perform the same initial adjustment on the Idle Mixture Adjusting Screw. This initial adjustment should permit the engine to be started and warmed up.

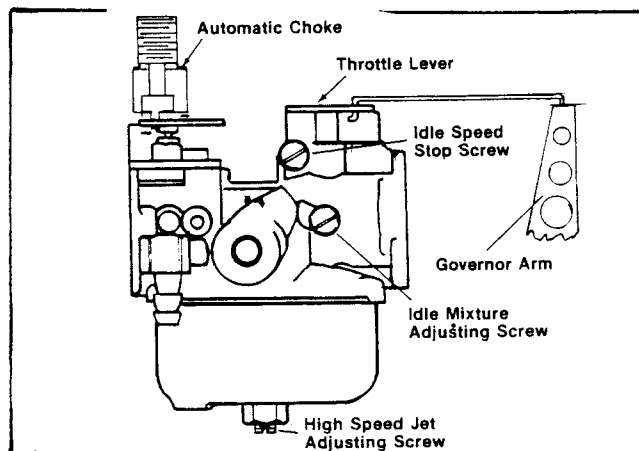

RESULTS:- Engine starts.....Go to Paragraph B
 Engine will not start.....Go to Paragraph D

B.)- Set VOM to "250V." scale and to "AC". Connect the meter test leads to a convenient AC outlet powered by the alternator. Hold the Carburetor Throttle Lever against its Idle Speed Stop Screw. Adjust Idle Speed Stop Screw until meter indicates 60 Volts a-c. When a 60 Volt reading is obtained, turn Idle Mixture Adjusting Screw until voltage starts to drop off. Then turn the screw in the opposite direction until voltage reading again starts to decrease. Finally, reverse direction again and turn the screw until the highest voltage reading is obtained. Release Throttle Lever and let engine accelerate and stabilize.

C.)- With engine running at governed speed, apply a normal load to the alternator. Connect an accurate frequency meter to the unit's a-c output. Turn the High Speed Jet Adjusting screw slowly clockwise then counterclockwise until the highest frequency is obtained. When the Jet is set for the highest possible frequency, turn adjusting screw counterclockwise 1/8 turn.

RESULTS:- Engine starts and runs normally.....Discontinue Tests
 Engine will not start or starts and runs rough.....Go to Paragraph D

D.)- Remove Fuel Bowl from Carburetor Body. Inspect Float Valve, Seat and Gasket for damage, dirt or wear. Replace defective components. Also check for proper Float setting. Top of Float should be 0.070 - 0.110 inch below Carburetor Body mounting Flange. See illustration at right.

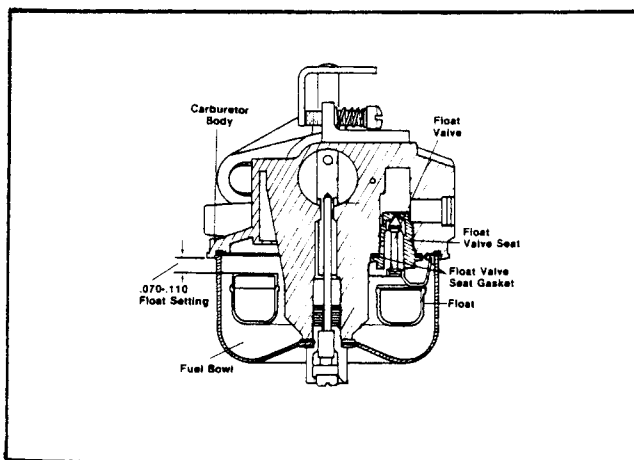

RESULT:- Float Valve, Seat, Gasket and
 Float level are good.....Continue Diagnostic Tests
 Float Valve, Seat, Gasket or
 Float level check bad.....Replace or adjust, then test

TEST 24:- COMPRESSION

A.)-Insert a standard compression gauge into engine spark plug hole. Open throttle wide open and crank engine. Compression should be approximately 75-85 psi (cold) or 95-105 psi (hot).

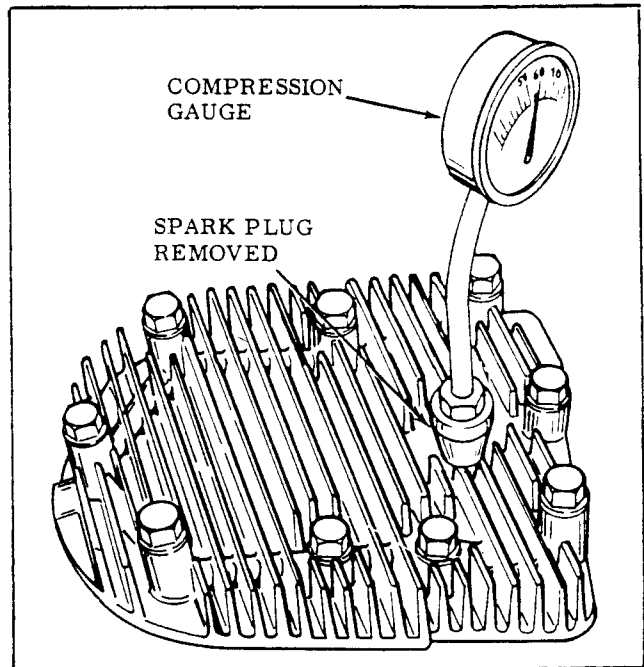

RESULT:- Compression reading good.....Go to Test 29
 Compression reading low.....Continue tests

B.)- Squirt a few drops of clean engine oil into spark plug hole on engine cylinder head. Repeat compression test. If compression reading is higher than was obtained in Paragraph A, ring or cylinder wear is indicated. If little or no difference in compression was noted, trouble may be due to head gasket leakage, worn valves, etc.

RESULT:- Noticeable increase in
 compression obtained.....Go to Test 27
 Little or no increase in compression.....Go to Test 25

TEST 25:- HEAD GASKET

Crank the engine. A "hissing" sound at the spark plug indicates the plug is loose or broken. Likewise, "hissing" at the cylinder head indicates loose head nuts or a leaking head gasket. Tighten loose spark plug, replace broken spark plug using a new plug gasket. If cylinder head leaks, check for warped cylinder head and for a defective head gasket. Refer to engine section of manual and to TORQUE SPECIFICATIONS (SPECIAL).

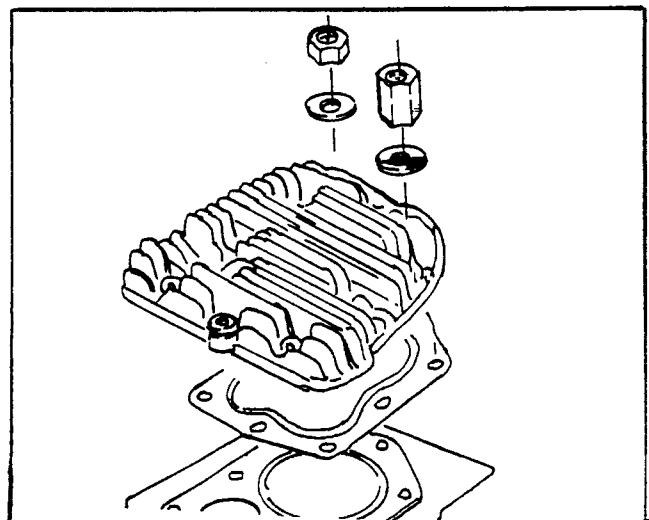

TEST 26:- VALVES

Remove valves. Clean all parts in non-flammable solvent. Remove all carbon. Replace damaged or distorted valves. If valves are useable, lap them as outlined in engine section. Check for correct tappet clearance as outlined in engine section of manual.

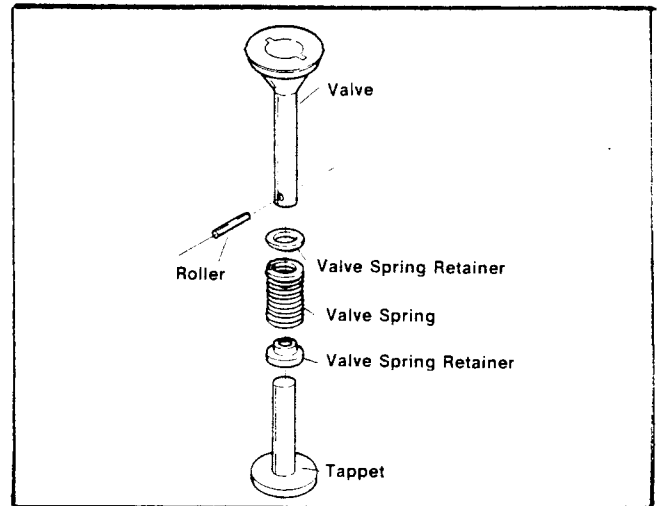

TEST 27:- RINGS

Check for broken or worn rings. Check ring clearance in piston grooves and ring gap. Refer to engine section of manual.

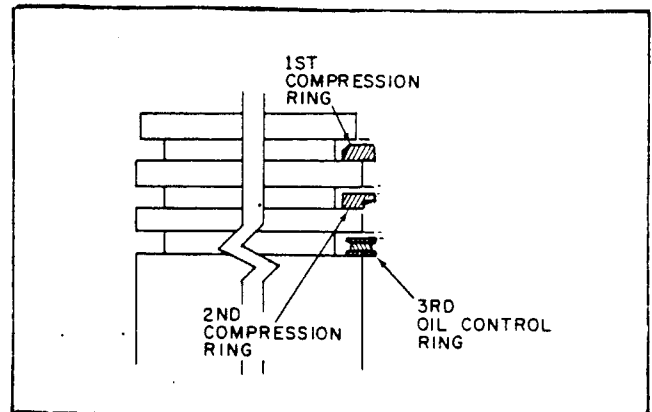

TEST 28:- CYLINDER

Inspect cylinder walls for burning, scoring or scratching. Check cylinder inner diameter. Refer to engine section of manual for inspection requirements.

TEST 29:- TIMING

The ignition magnet is retained to the fan with a special adhesive which is cured at 300°F. for 1 hour (or 265°F. for 1½ hours) after installation. The ring gear is heated and pressed over the fan and magnet assembly. The entire assembly is then balanced as a unit, and finally heated and epoxied into place over the rotor shaft. Any damage to the Rotor, Fan, Magnet or Ring Gear is cause for replacement of the entire assembly.

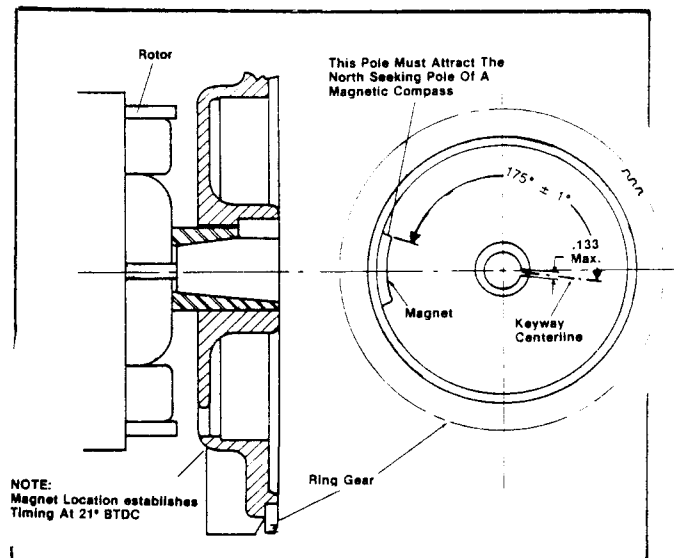

Timing is established at 21 BTDC by the physical location of the magnet on the fan. Thus any damage that results in a physical change in the magnet's location will cause an "out-of-time" condition. Check for a damaged key or keyway that might have caused slippage of the fan on the rotor shaft.

TEST 30:- CHOKE

A.)-Crank the engine. The Choke Solenoid should pulse from Choke OPEN to Choke CLOSED position at a rate dependent on ambient temperature.

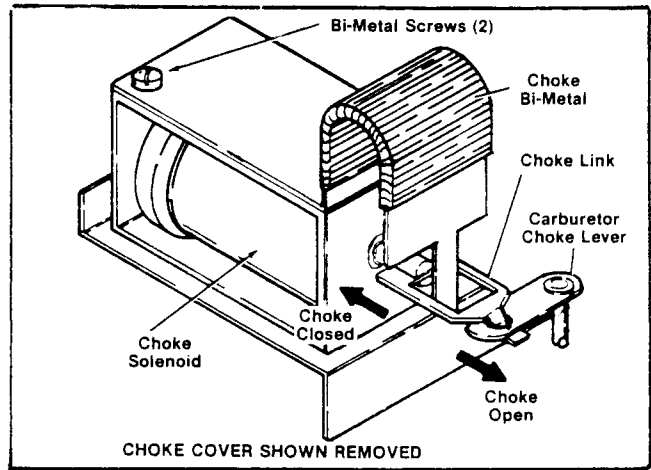

RESULTS:- Choke movement is good.....Go to Test 31, PRE-CHOKE
 Choke does not move.....Go to Paragraph B

B.)-Check the Choke assembly for binding or sticking caused by improper alignment, dirt, etc. Move Choke back and forth with finger- there should be no evidence of binding or sticking.

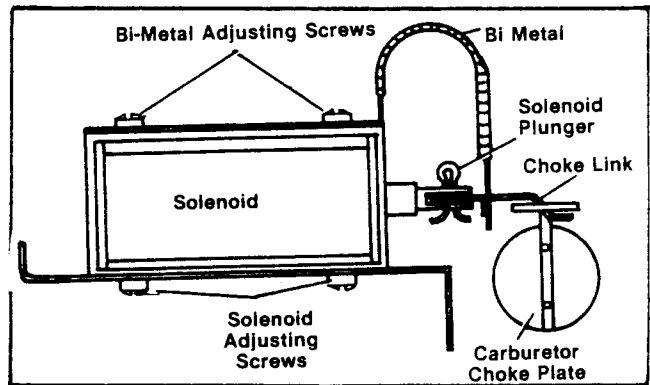

RESULTS:- Choke is binding.....Adjust or clean choke linkage
 Choke moves freely.....Go to Paragraph C

C.)- Loosen the two Solenoid Adjusting screws. Adjust axial movement of solenoid plunger so that, with carburetor choke plate closed, the choke solenoid plunger is bottomed. Tighten the two adjusting screws and check again for correct choke action.

RESULTS:- Choke solenoid pulls in normally.....Go to Test 31
 Solenoid does not pull in.....Go to Paragraph D

D.)-Set VOM to "+DC" and to "50V." scale. Connect the positive (+) meter test probe to the Wire No. 91 terminal on the choke solenoid and the remaining test probe to frame ground. Crank the engine - meter needle should swing upscale and indicate a steady 12 Volts DC.

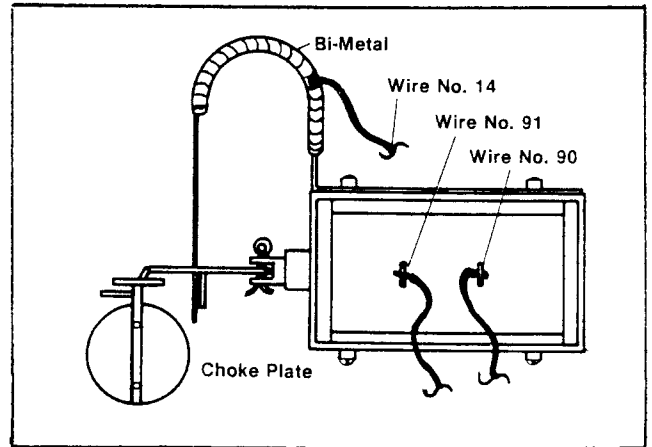

RESULTS:- Meter does not indicate 12 Volts....Check Wire No. 91 for an open or shorted condition
 Meter indicates 12 Volts DC.....Go to Paragraph E

E.)- Set VOM to "+DC" and to "50V." scale. Connect the positive (+) meter test probe to the Wire No. 90 terminal on the choke solenoid and the common (-) test probe to frame ground. Crank the engine - meter needle should indicate a pulsing voltage as choke pulses open and closed.

RESULTS:- No meter needle movement.....Replace Printed Circuit Board (Model 6897-4:-Replace Choke Pulse Module [CM]. See Section 2.4.)

Meter test is good but choke does not actuate.....Replace Choke assembly

TEST 31:- PRE-CHOKE

With the choke Bi-Metal at ambient temperature, the carburetor choke plate should be approximately 1/8 inch away from its full open position (toward the closed position). If necessary, loosen the bi-metal adjusting screws and move the bi-metal to obtain this setting. This is the "Pre-Choke" position.

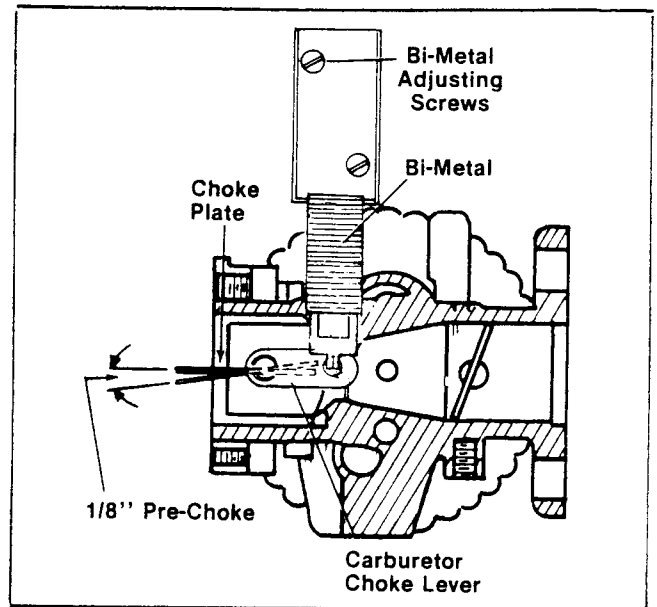

TEST 32:- GOVERNOR

A.)- Adjust Carburetor as outlined in Test 23. The Carburetor must be adjusted BEFORE attempting to adjust the Governor.

RESULT:- Problem is corrected.....Test completed
Engine "hunts" and/or a-c voltage
or frequency is incorrect.....Go to Paragraph B

B.)-Make sure Governor Spring is connected to Governor Arm and to Governor Adjusting Screw. Loosen Engine Governor Shaft Clamp Nut and turn Engine Governor Shaft counterclockwise as far as it will go. Then tighten Governor Shaft Clamp Nut and torque to 110 inch-pounds.

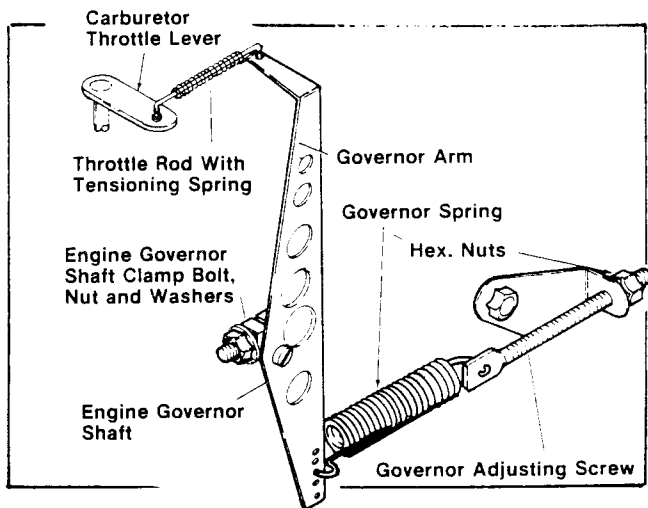

RESULT:- Engine runs normal, provides
62 Hertz at no-load.....Test completed
Engine hunts and/or a-c voltage
or frequency is incorrect.....Go to Paragraph C

C.)- With engine running, adjust hex nuts at end of Governor Adjusting Screw to obtain 62 Hertz at no-load. One hex nut serves as a jam nut - make sure this nut is tight when 62 Hertz is obtained.

RESULT:- Engine runs normal.....Test completed
Engine hunts.....Set Carburetor for richer mixture

NOTE

All mechanical governors have a normal offspeed fluctuation. This is the reaction time of the governor.

TEST 33:- CHECK FREQUENCY

Use an accurate Frequency Meter to check alternator output frequency. Frequency should be 62 Hertz at no-load. With a normal electrical load applied, frequency should be 59-62 Hertz and stable (disregarding the normal offspeed fluctuation).

TEST 34:- EXCITATION WINDINGS

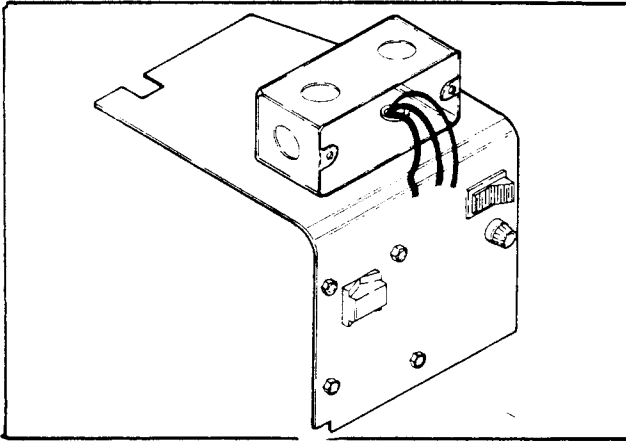

Remove the alternator front panel assembly.

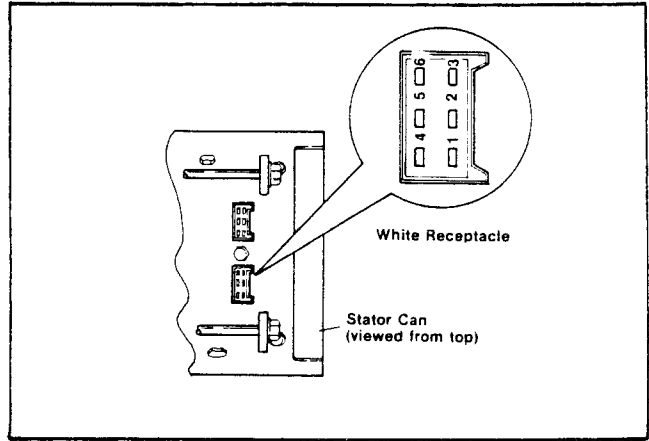

Disconnect the white connector plug from its receptacle on the stator can. On the receptacle, locate Pin No. 2 and 6 to which Wires No. 2 and 6 attach. Set VOM to "+DC" and to "Rx1" scale, then zero the meter. Connect one meter test probe to receptacle Pin No. 2. Connect the remaining test probe to receptacle Pin No. 6. Meter needle should swing up-scale and read approximately 1.1 Ohms. This is the resistance of the excitation winding.

RESULT:- Meter needle does not move.....Replace stator Windings check good.....Continue diagnostic tests

TEST 35:- CARBON DEPOSITS

Excessive carbon buildup in the engine combustion section can seriously affect engine power. Carbon deposits should be removed every 500 operating hours, whenever the cylinder head is removed, or when problems are encountered. Refer to the engine section of Manual for cylinder head removal and installation procedures. Cylinder head bolts must be properly located and properly torqued.

RESULT:- Power output is normal.....Discontinue tests Problem is still encountered.....Continue diagnostic tests

TEST 36:- CHECK VOLTAGE

Disconnect customer wiring from Wires No. T1 and T2 in alternator connection box. Check a-c voltage output at Wire No. T1 and junction of Wires T2. Reading should be approximately 125 Volts a-c at no-load and 115-125 Volts a-c under load.

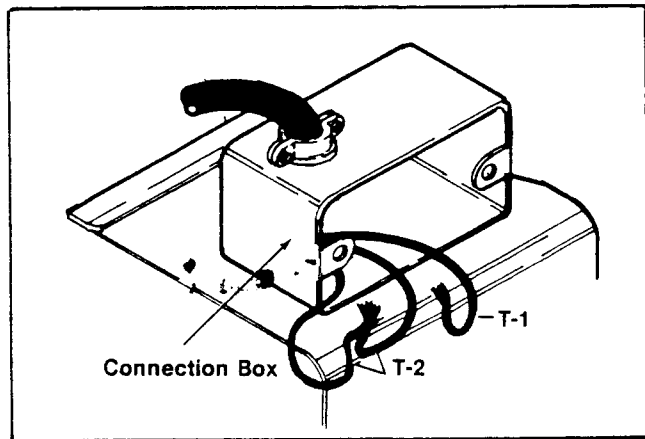

RESULT:- Voltage output bad.....Continue diagnostic tests
Voltage checks good.....Check customer wiring

NOTE

Alternators are factory connected to provide a 120 Volt a-c output only. Some units may have been reconnected to supply 120/240 Volts a-c. See Page 1.2-3.

TEST 37:- SENSING TRANSFORMER

A.)-Remove 2 wire nuts that connect wires No. 11 and 22, between Sensing Transformer and Voltage Regulator. Disconnect the wires. Set VOM to "+DC" and to "Rx100" scale, then zero the meter. Connect meter test probes across wires No. 11 and 22 from the Sensing Transformer. Meter needle should swing upscale and indicate secondary winding resistance. See illustration at right.

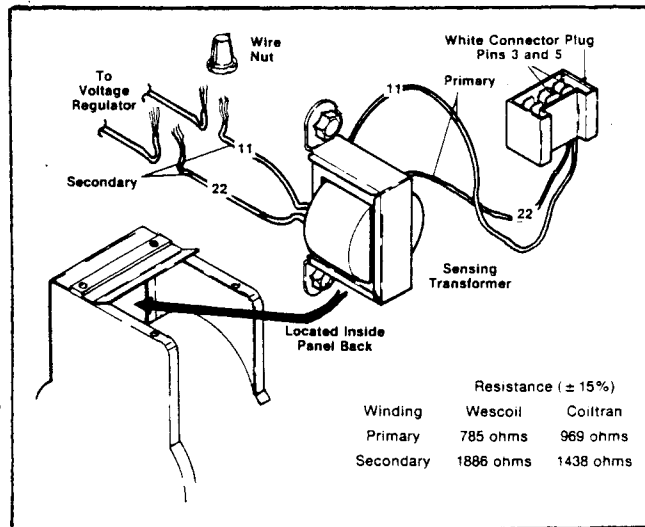

RESULT:- Secondary winding resistance checks good.....Go to Paragraph B
Meter needle does not swing upscale.....Replace Transformer

B.)- Unplug the white connector plug from its receptacle on the stator can. Set VOM to "+DC" and to "Rx10,000" scale. Zero the meter. Connect one meter test probe to white connector plug Pin No. 3. Connect the remaining probe to white connector plug Pin No. 5. Meter needle should swing upscale and indicate PRIMARY winding resistance. See illustration above right.

RESULT:- Primary winding resistance checks good...Check customer wiring
Primary winding resistance is bad.....Replace Transformer

NOTE

The Sensing Transformer secondary windings MUST connect to the Voltage Regulator. The primary windings must connect to the white connector plug. In most cases, primary and secondary windings will be identified when replacing a Transformer. If the windings are not identified, check winding resistance. The winding having the HIGHEST resistance is the SECONDARY winding.

TEST 38:- MAIN CIRCUIT BREAKER

Set VOM to "+DC" and to "Rx1" scale. Zero the meter. See illustration at right. Connect VOM test probes across the Main Breaker test points. Meter needle should swing upscale to zero with Main Breaker ON. When the Breaker is set to OFF, needle should drop all the way downscale (infinity).

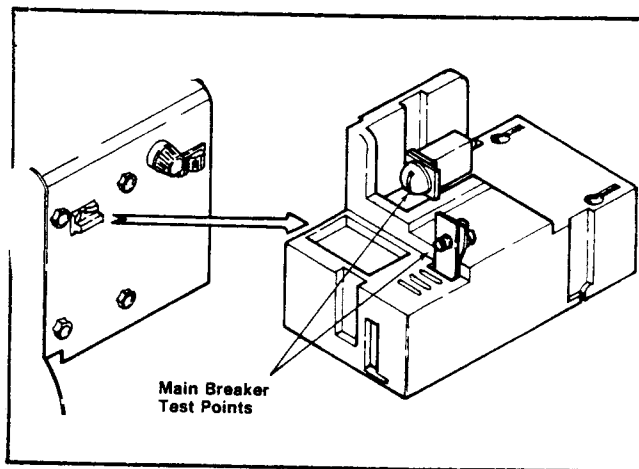

RESULT:- Main Breaker checks good.....Continue diagnostic tests
Main Breaker tests bad.....Replace Breaker

TEST 39:- CHECK ROTOR

A.)-Disconnect the white connector plug from its receptacle on the stator can. Set VOM to "+DC" and to "Rx1" scale, then zero the meter. Connect the positive (+) meter test probe to white receptacle Pin 4. Connect the common (-) probe to receptacle Pin 1. Meter needle should swing upscale and indicate rotor winding resistance (approximately 15.6 Ohms).

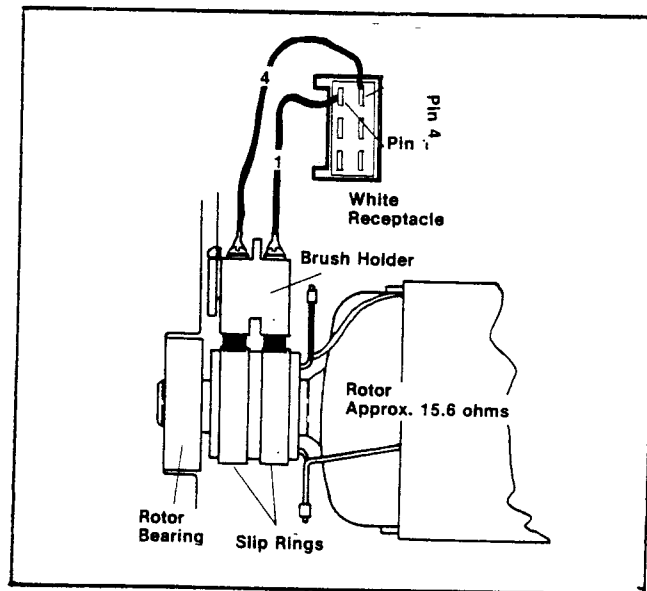

RESULT:- Rotor checks goodGo to Test 40
Rotor checks bad.....Go to Paragraph B

B.)-If rotor checks bad in Paragraph A, check Wires No. 1 and 4 for an open or shorted condition. Inspect brushes - replace if cracked, chipped or less than 5/16 inch long. Inspect slip rings and clean with fine sandpaper, if necessary. Make sure brushes are making good contact with slip rings. Finally, recheck rotor winding resistance at Pins 1 and 4 of white receptacle as outlined in Paragraph A.

RESULT:- Wires, slip rings and brushes
 check good but rotor still
 checks bad.....Replace rotor
 Wires, slip rings or brushes
 check bad.....Repair, clean or replace

TEST 40:- CHECK FIELD BOOST (To check Field Boost Module on Model 6897-4 refer to Section 2.4.)

Unplug the Ignition Module to prevent the engine from starting. Also unplug the red connector plug from its receptacle on the stator can. Set VOM to "+DC" and to any scale that will permit 12 Volts to be read. Connect the positive (+) meter test probe to red connector plug Pin 5. Connect the negative (-) test probe to frame ground. Crank the engine - meter needle should swing upscale and indicate approximately 9 - 12 Volts d-c.

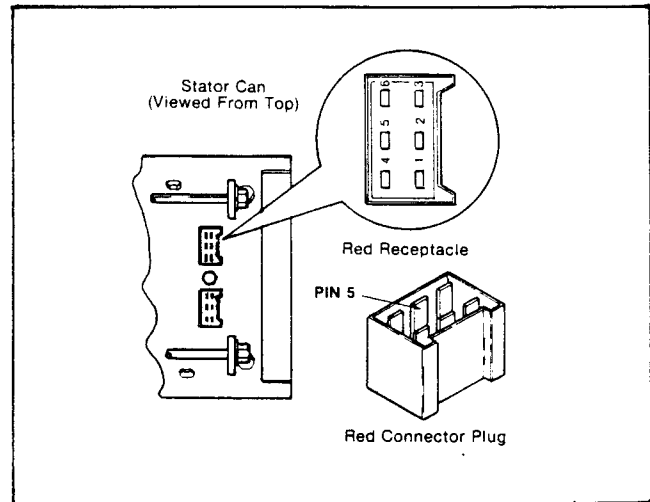

RESULT:- No field boost voltage indicated.....Go to Paragraph B
 Field boost voltage checks good.....Continue diagnostic tests

B.)-Unplug connector plugs from the Printed Circuit Board and from the red receptacle on stator can. Set VOM to "+DC" and to "Rx1" scale, then zero the meter. Connect one meter test probe to Pin No. 2 of the printed circuit board connector plug. Connect second test probe to Pin No. 5 of the red connector plug. Meter needle should swing all the way upscale to zero.

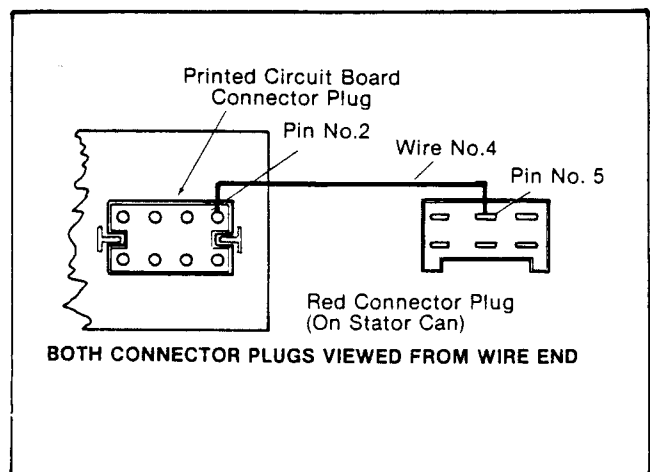

RESULT:- Meter indicated zero.....Replace printed circuit board
 Meter did not swing upscale.....Repair/replace Wire No. 4 or defective connector plug

TEST 41:- CHECK STATOR

A.)- Set VOM to "+DC" and to "Rx1" scale, then zero the meter. Connect meter test probes to Pins 1 and 2 of red receptacle on stator can. Meter needle should swing upscale and indicate approximately 0.42 Ohms.

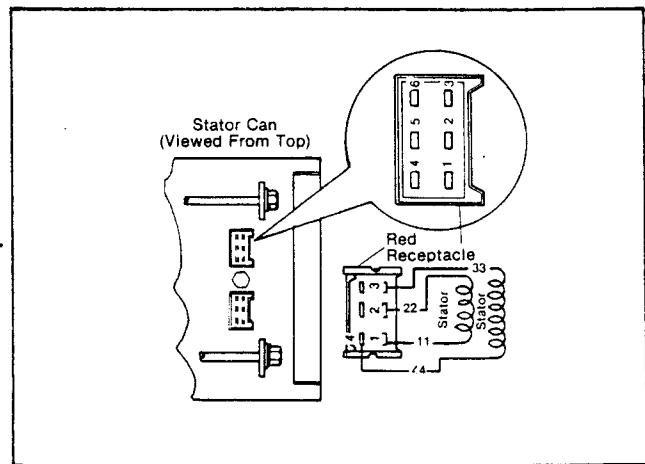

RESULT.- Meter needle did not move.....Replace stator
Checks good.....Go to Paragraph B

B.)- With VOM still set to "+DC" and to "Rx1" scale, connect meter test probes to red receptacle Pins 3 and 4. Meter needle should swing upscale and indicate approximately 0.42 Ohms.

RESULT:- Meter needle did not move.....Replace stator
Checks good.....Go to Paragraph C

C.)- Set VOM to "+DC" and to "Rx10,000" scale, then zero the meter. Connect one meter test probe to red receptacle Pin 1 and the second test probe to frame ground. Meter needle should not move. Repeat test with one test probe connected to red receptacle Pin 3 and the second probe to frame ground. Meter needle should not move.

RESULT:- Meter needle moved upscale.....Replace stator
Checks good.....Continue diagnostic tests

SECTION 2.3

BATTERY CHARGE CIRCUIT TESTS

CHARGING CURRENT

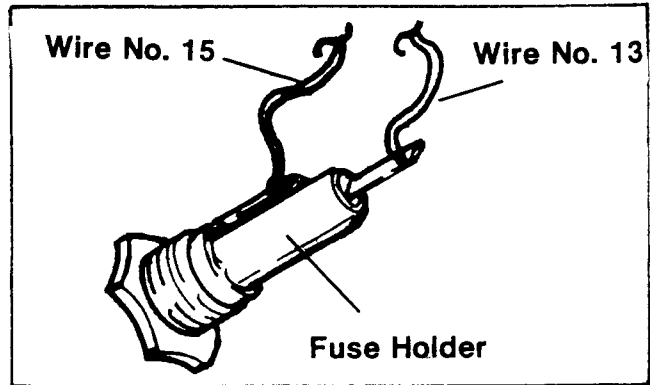
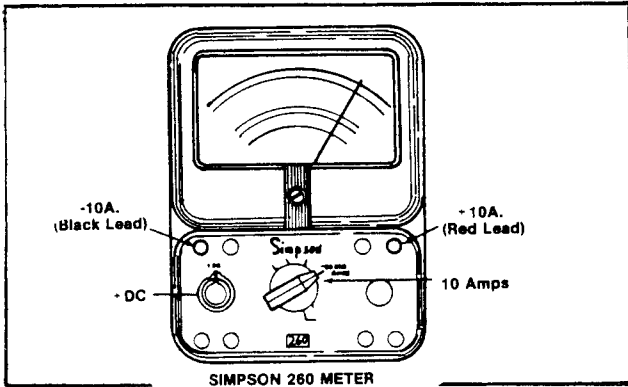

1.)- Plug the black (-) test lead into the "-10A" jack on the VOM. Plug the red (+) test lead into the "+10A" jack on the meter. Set the meter range switch to "10 Amps" (dual position with 10 MA).

2.)-Locate the 15 Amp Fuse inside the alternator control panel. Connect the red meter test probe to the Wire 15 terminal on the Fuse Holder. Connect the black test probe to the Wire 13 terminal on the Fuse Holder.

3.)-Start the alternator. With the engine running, remove the 15 Amp Fuse from its holder. With the Fuse removed, the alternator should indicate a current output dependent on battery condition.

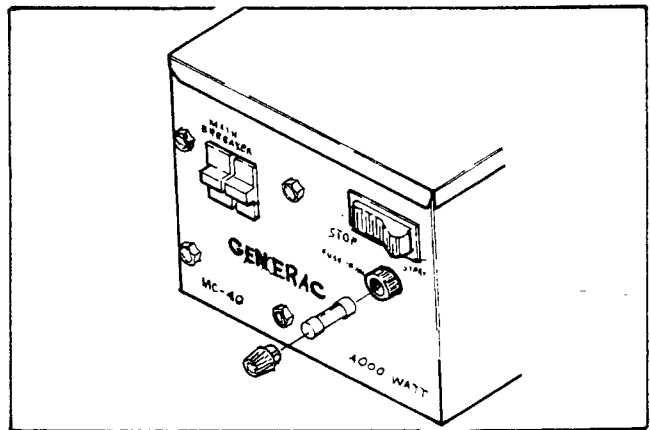

RESULT:- Ammeter indicates a current output.....Discontinue tests
 No current output indicated.....Continue tests

CIRCUIT BREAKER CB-2

Disconnect Wires No. 77 and 78 from the battery charge circuit breaker (CB-2). Set VOM to "+DC" and to "Rx1" scale, then zero the meter. Connect the meter test probes to the circuit breaker terminal studs. Meter needle should swing upscale to zero. If it does not swing upscale, replace the circuit breaker.

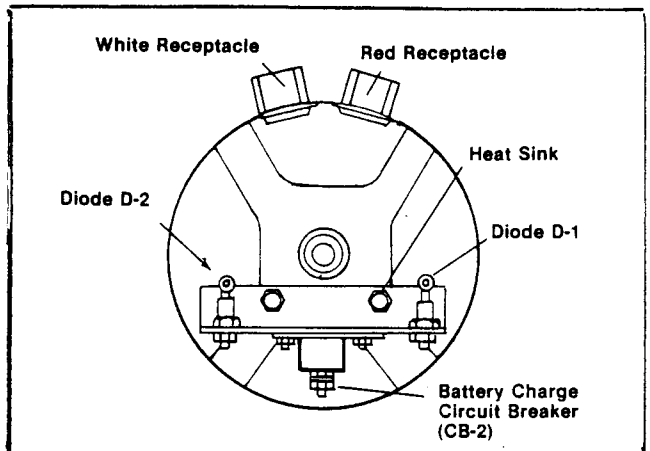

DIODES D1 AND D2

A.)- Disconnect Wire No. 78 at the circuit breaker CB-2. Set the VOM to "+DC" and to "Rx1" scale. Zero the meter. Connect the positive (+) test probe to Wire No. 78 from the Diode D-2. Connect the common (-) test probe to frame ground. Meter needle should not move. Set meter to "-DC", or reverse the meter test probes. Meter needle should swing upscale to some mid-scale reading (approximately 7-12 Ohms).

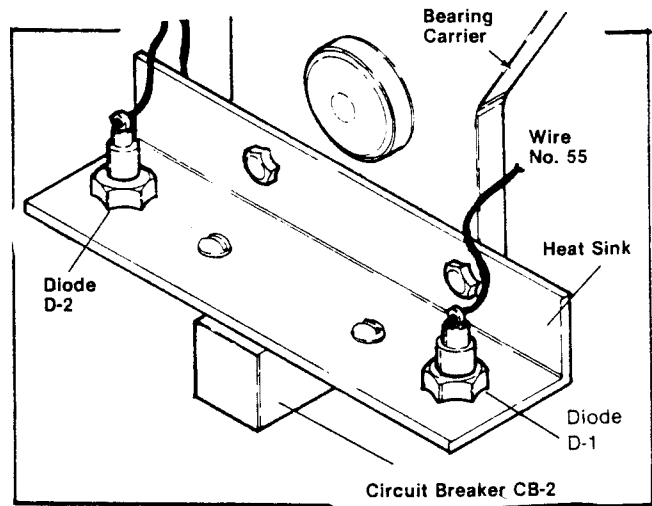

RESULT:- Diode D-2 tests good.....Reconnect Wire 78, go to Paragraph B
 Diode D-2 tests bad.....Replace Diode D-2

B.)- Set VOM to "+DC" and to "Rx1" scale, then zero the meter. Connect the positive (+) test probe to the Diode D-1 terminal end. Connect the common (-) test probe to frame ground. Meter needle should not move. Set meter to "-DC" or reverse the test probes. Meter needle should move upscale.

RESULT:- Diode D-1 tests good.....Continue tests
 Diode D-1 tests bad.....Replace Diode D-1

STATOR BATTERY CHARGE WINDINGS

Disconnect Wire 77 from Circuit Breaker CB-2. Unplug the red connector plug from its receptacle on the stator can. Set VOM to "+DC" and to "Rx1" scale, then zero the meter. Connect one meter test probe to Wire 55 at the Diode D-1 terminal. Connect second test probe to Pin 6 of the red receptacle. Meter needle should swing upscale (approximately .08 Ohm). Repeat test with meter test probe connected to red receptacle Pin 6 and Wire 77 - meter should indicate approximately .08 Ohm.

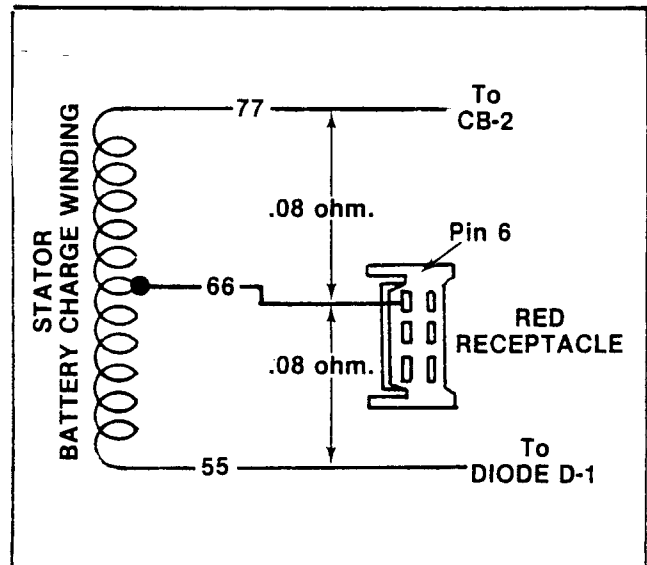

RESULT: Both meter readings were approximately
 .08 Ohm.....Test good
 Meter needle did not indicate .08 Ohm.....Replace stator

SECTION 2.4

MODEL 6897-4

2.4.1- GENERAL

2.4.1.1- INTRODUCTION

The Model 6897-4 (MC-40) alternator incorporates several new components in its DC control system. The new components replace the printed circuit board used on earlier models. They will improve starting and simplify component testing, removal and replacement. New components are:-

- 1.)- Choke Pulse Module (CM)
- 2.)- Control Relay (CR)
- 3.)- Field Boost Module (FB)

2.4.1.2- CHOKE PULSE MODULE

The Choke Pulse Module performs several important functions, related to engine starting. These functions are:-

- 1.)-Provides the necessary components for delivery of a pulsing voltage to the automatic choke solenoid during cranking.
- 2.)-Provides the required circuitry for energizing the fuel lock-off solenoid and (electric) fuel pump during cranking, before the control relay (CR) is energized.

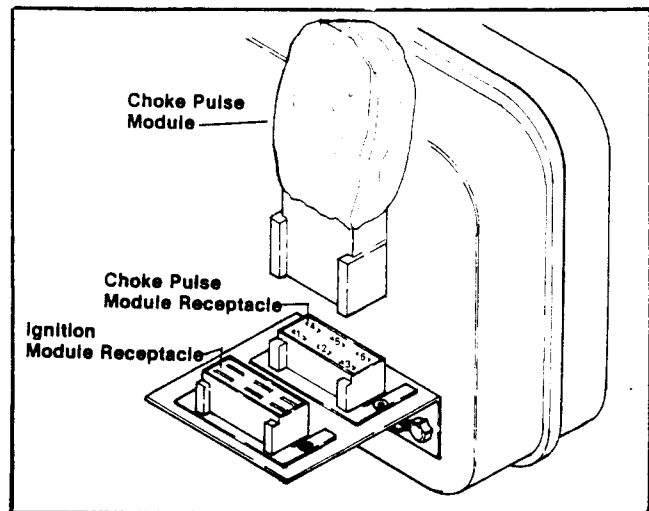

2.4.1.3- CONTROL RELAY (CR)

The Control Relay (CR) is equipped with a pushbutton for manually closing the CR contact. The pushbutton can be identified by the words FUEL PUMP on the unit control panel. To prime the carburetor prior to cranking the engine, depress the pushbutton. This action will energize the Fuel Lockoff Solenoid open and operate the (electric) Fuel Pump. After a start, the CR remains energized to hold the Fuel Lockoff Solenoid open and operate the Fuel Pump. (While cranking, part of the Choke Pulse Module circuit performs the latter function.)

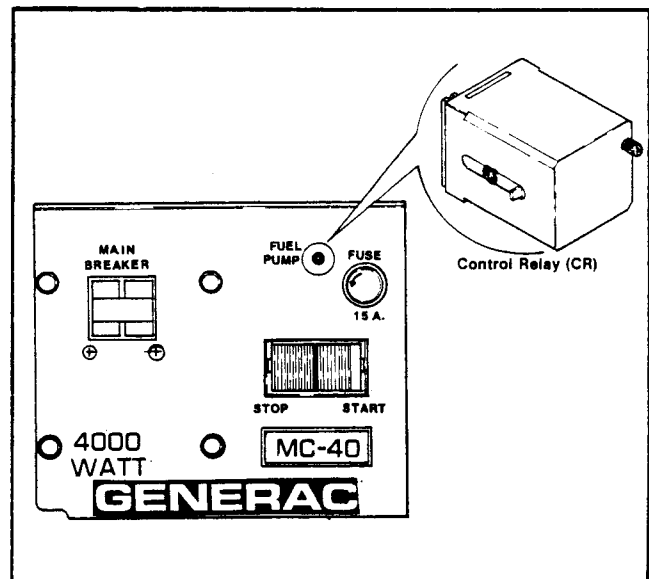

2.4.1.4- FIELD BOOST MODULE (FB)

Many alternators rely on residual or "stored" magnetic energy to provide the initial magnetic field around the rotor windings. Residual magnetism can be lost due to aging, shock or physical damage. The MC alternator is equipped with a Field Boost Module (FB) which supplies battery current to the rotor windings during each start.

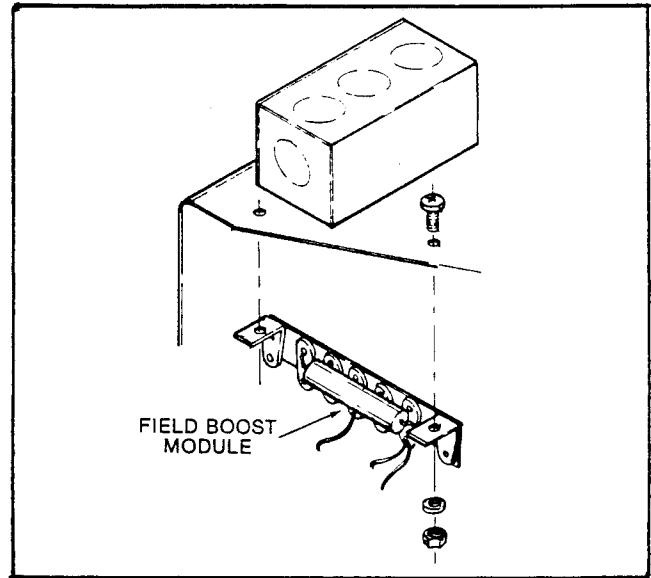

2.4.2- CIRCUIT OPERATION

2.4.2.1- PRIMING

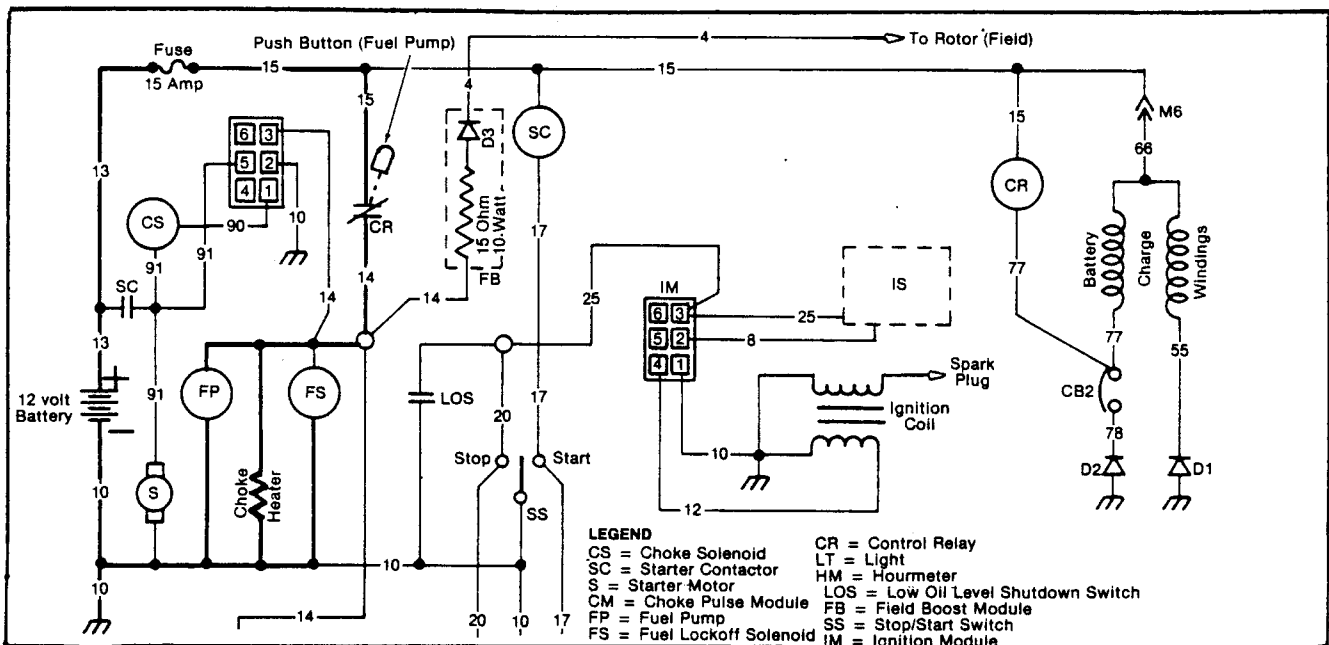

Battery power is available through Wire No. 13, the 15 Amp Fuse, and Wire No. 15 to the Control Relay (CR) contacts. When the push button (FUEL PUMP) is depressed, the CR contacts close. This completes the 12 Volt DC circuit through Wire No. 14, the Fuel Lockoff Solenoid (FS), Fuel Pump (FP), and the Choke Heater to frame ground. The Fuel Lockoff Solenoid is energized open and the Fuel Pump operates.

2.4.2.2- CRANKING

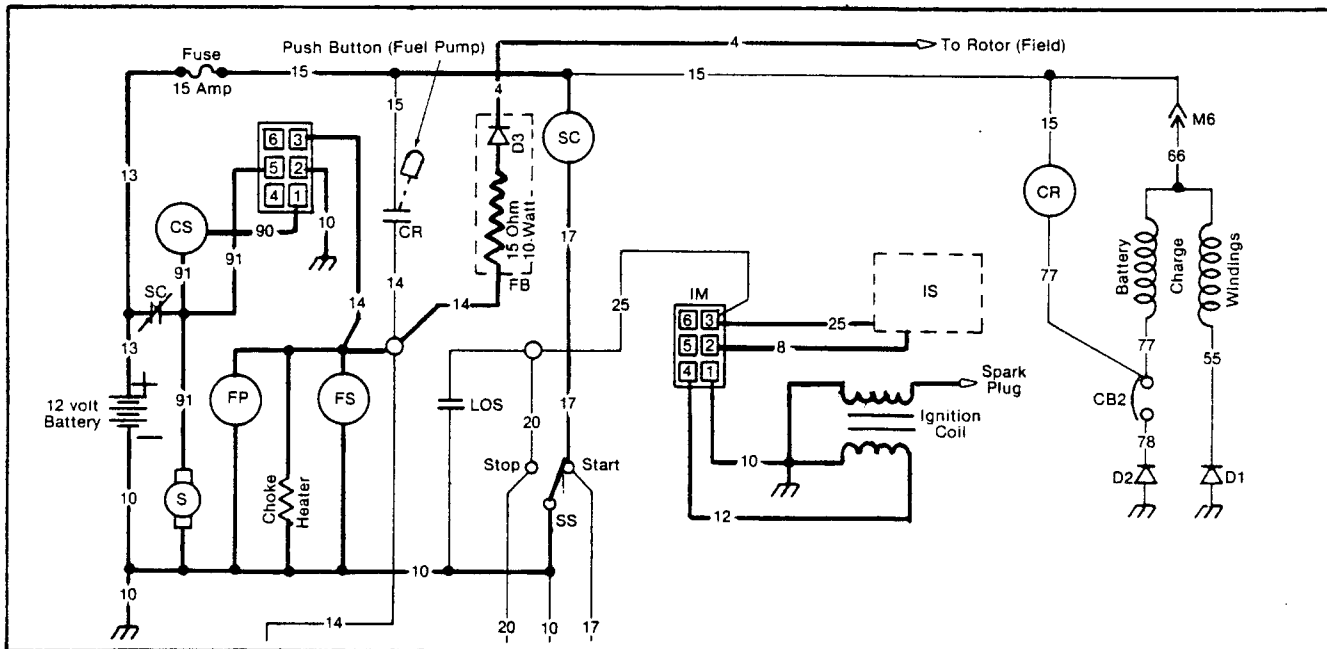

Battery power is available to the Stop/Start Switch via Wire No. 13, the 15 Amp Fuse, Wire No. 15, the Starter Contactor (SC), and Wire No. 17. When the Stop/Start Switch is set to START position, the circuit is completed through Wire No. 10 to frame ground. The Starter Contactor (SC) energizes and its contacts close. With the SC contacts closed, several events occur as follows:-

- 1.)- Battery power is supplied through Wire No. 91 to the Starter Motor and to frame ground. The engine cranks.
- 2.)- Battery power is supplied through Wire No. 91, through the Choke Solenoid (CS), Wire No. 90, and to Pin No. 1 of the Choke Pulse Module (CM). Solid state components within the CM open and close this circuit through CM Pin No. 2 and Wire No. 10 to ground, at a rate dependent upon ambient temperature. The Choke Solenoid (CS) is thus pulsed and the automatic choke operates at a rate dependent on ambient temperature.
- 3.)- Battery power is supplied across the closed SC contacts, through Wire No. 91, to Pin No. 5 of the Choke Pulse Module (CM). The circuit is completed within the CM, through Pin No. 3, through Wire No. 14, the Fuel Lockoff Solenoid (FS), the Fuel Pump (FP), Choke Heater and through Wire No. 10 to frame ground. The Choke Heater energizes, the Fuel Lockoff Solenoid (FS) opens, and the Fuel Pump (FP) operates.
- 4.)- As the engine cranks, the Ignition Stator (IS) supplies a voltage pulse to the Ignition Module (IM). The Ignition Module in turn supplies a timed voltage pulse to the Ignition Coil primary winding. The buildup and collapse of this voltage pulse induces a voltage into the Ignition Coil secondary winding to fire the spark plug.
- 5.)- Battery power is supplied through Wire No. 14 to the Field Boost (FB) module. A 15 Ohm, 10 Watt resistor reduces this voltage and a Diode (D3) ensures correct polarity. The reduced voltage is delivered to the rotor windings via Wire No. 4.

2.4.2.3- RUNNING

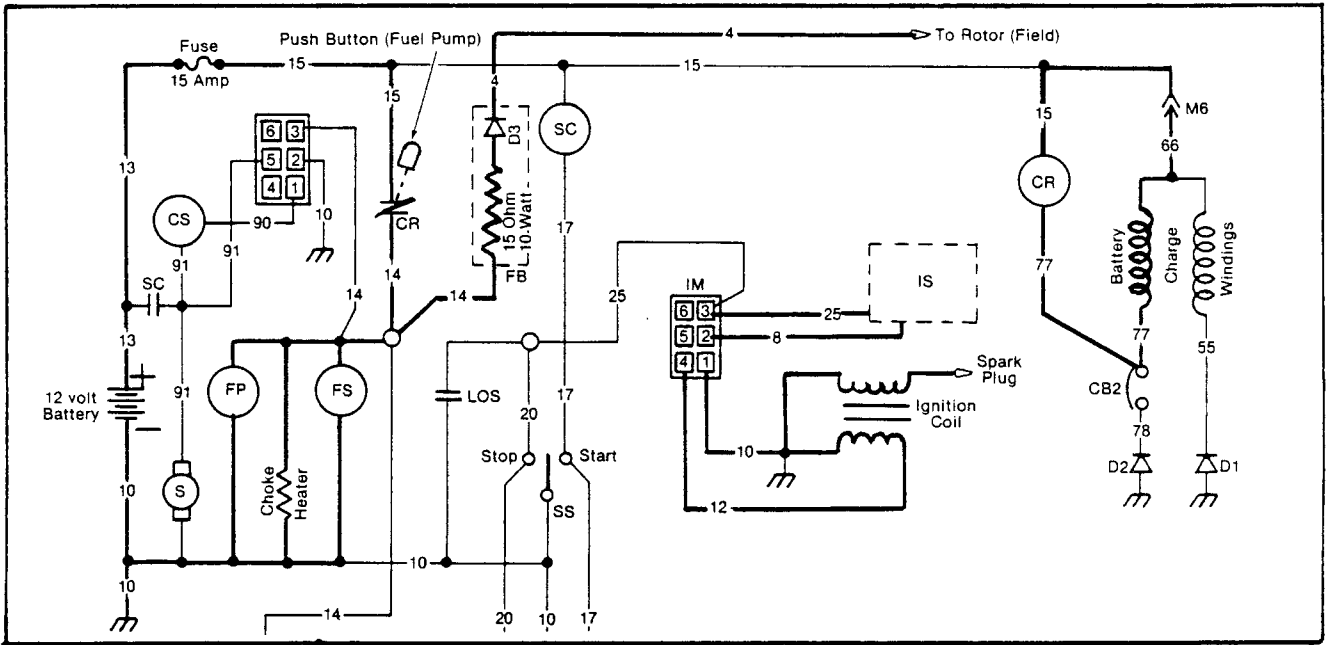

Releasing the Stop/Start Switch to NEUTRAL opens the DC circuit from the battery, Wire No. 13, 15 Amp Fuse, Wire No. 15, Starter Contactor (SC), and Wire No. 17. The SC de-energizes and its contacts open to terminate cranking and choke operation. The Control Relay (CR) is held energized by AC output from the Battery Charge Windings, and the CR contacts close. Battery power is delivered through the closed CR contacts to the Fuel Pump (FP), Fuel Lockoff Solenoid (FS), and Choke Heater to maintain engine operation. The Ignition System continues to function and Field Boost current is still available.

2.4.2.4- SHUTDOWN

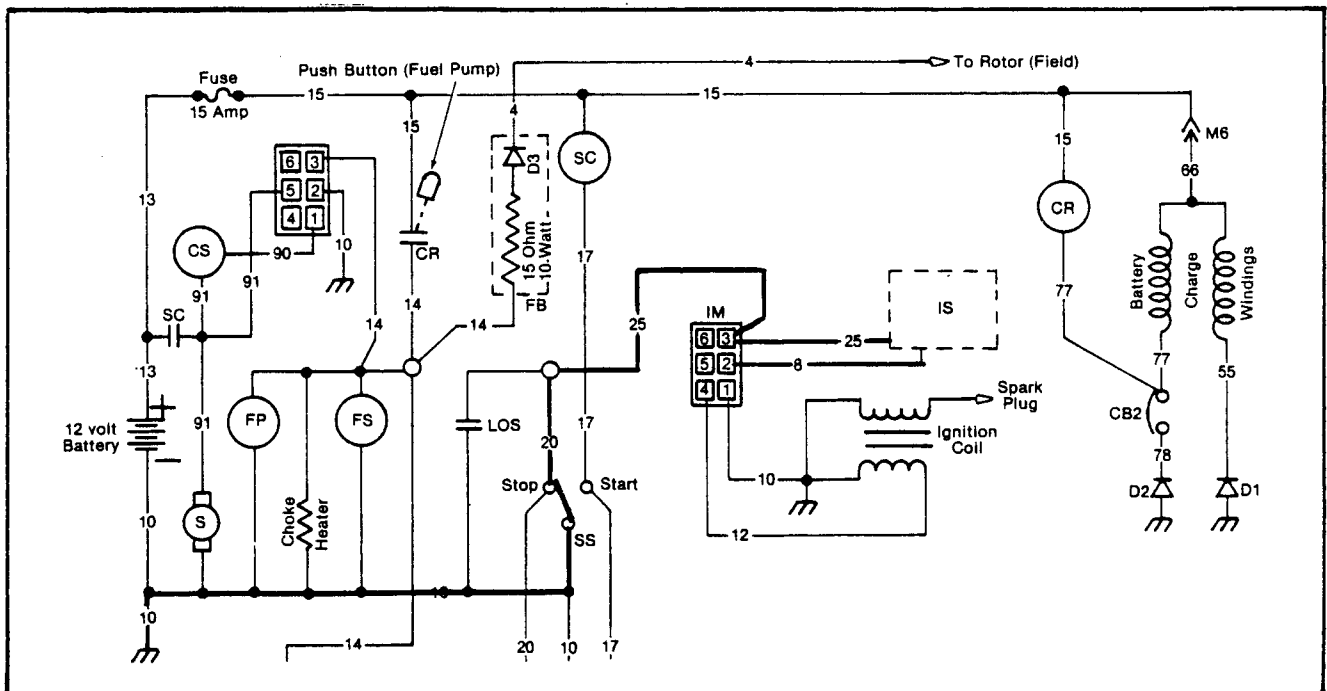

When the Stop/Start Switch is set to STOP, Ignition Stator (IS) output from Wire No. 25, Ignition Module (IM) Pin No. 3, Wire No. 25 to the Terminal Block and Wire No. 20 is delivered to frame ground. Ignition terminates and the engine shuts down. The Control Relay de-energizes and its contacts open to close the Fuel Lockoff Solenoid (FS) and terminate Fuel Pump (FP) operation.

2.4.3- DIAGNOSTIC TESTS

2.4.3.1- CHOKE PULSE MODULE

METHOD 1:- Install a known good Choke Pulse Module. Crank engine.

RESULT:- Choke operates normally.....Replace Choke Pulse Module
 Engine starts.
 Choke does not function and/or.....Continue Diagnostic Tests,
 no start Section 2.1

METHOD 2:- A.)-

Unplug Choke Pulse Module. Set VOM to "+DC" and to "50V." scale. Connect positive (+) meter test probe to Module receptacle Pin No. 1, common (-) test probe to frame ground. Crank engine. Meter should indicate 9-12 Volts DC. This is the input voltage to the Choke Pulse Module.

B.)-Plug Choke Pulse Module into its receptacle. Set VOM to "+DC" and to "50V." scale. From bottom of receptacle, connect positive (+) meter test probe into receptacle Pin No. 1 and common (-) test probe to frame ground. Crank engine. The meter should indicate a pulsing voltage and choke solenoid should pulse.

C.)-Plug Choke Pulse Module into its receptacle. Set VOM to "+DC" and to "50V." scale. From bottom of Module receptacle, connect positive meter test probe to receptacle Pin No. 3. Connect common (-) test probe to frame ground. Crank engine. Meter should indicate approximately 12 Volts DC.

RESULTS:-All tests were good....Continue diagnostic tests, Section 2.1

Test A checked bad.....Check Wire No. 90 between receptacle and Choke Solenoid, Choke Solenoid, Wire No. 91 between Choke Solenoid and Starter Solenoid (SC), Starter Solenoid (SC)

Test B checked bad.....Replace Choke Pulse Module (CM)

Test C checked bad.....Replace Choke Pulse Module (CM)

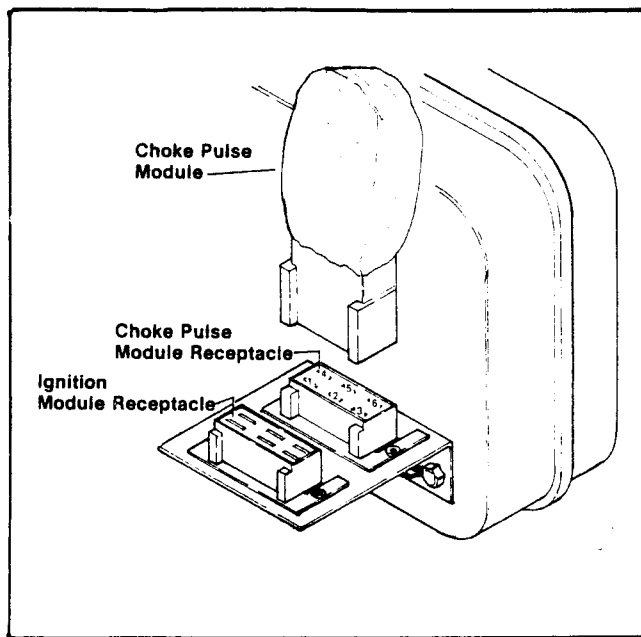

2.4.3.2- CONTROL RELAY (CR)

Refer to 2.4.1.3 and 2.4.2, this Section. If engine starts and then shuts down, the problem may be caused by the Control Relay (CR). Proceed as follows to check the Control Relay:-

A.)-With unit battery properly connected, depress Fuel Pump button. The Fuel Lockoff Solenoid should open and Fuel Pump should operate.

RESULT:-Checks good.....Go to Paragraph B
 Checks bad.....Check 15 Amp Fuse and priming circuit -
 See 2.4.2.1, PRIMING

B.)-Crank engine while holding Fuel Pump button depressed. Continue to hold button in after engine starts, then release.

RESULT:-Engine starts and runs normally,
 shuts down after button is rel-.....Go to Paragraph C
 eased
 No change - engine starts then...Continue Diagnostic Tests,
 shuts down as before Section 2.1

C.)-Set VOM to "AC". Connect one meter test probe to Pin No. 7 of the CR receptacle. Connect remaining test probe to receptacle Pin B, then crank engine. Meter should indicate approximately 10-12 Volts AC.

RESULT:- Checks good.....Replace CR
 Checks bad.....Check wires 15 and 77-
 If wires check good,
 replace stator assembly

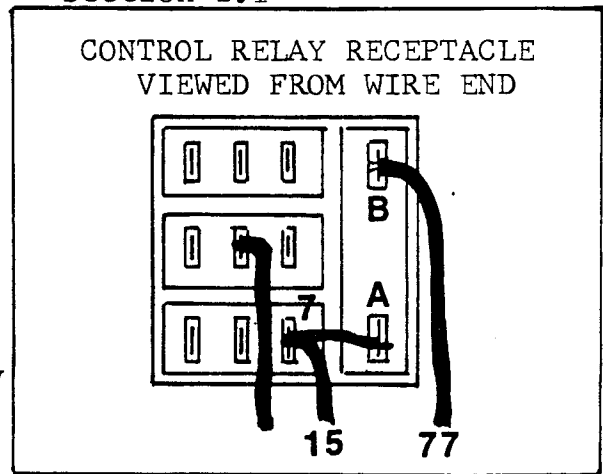

2.4.3.3- FIELD BOOST MODULE

A.)-Unplug red receptacle from its receptacle on stator can. Set VOM to "+DC" and to any scale that will permit 12 Volts to be read. Connect the positive (+) meter test probe to red connector plug Pin No. 5. Connect the common (-) probe to frame ground. Depress the Fuel Pump button - meter should indicate approximately 9-12 Volts DC.

RESULT:-Checks bad.....Go to Paragraph B
 Checks good.....Continue tests, Section 2.1

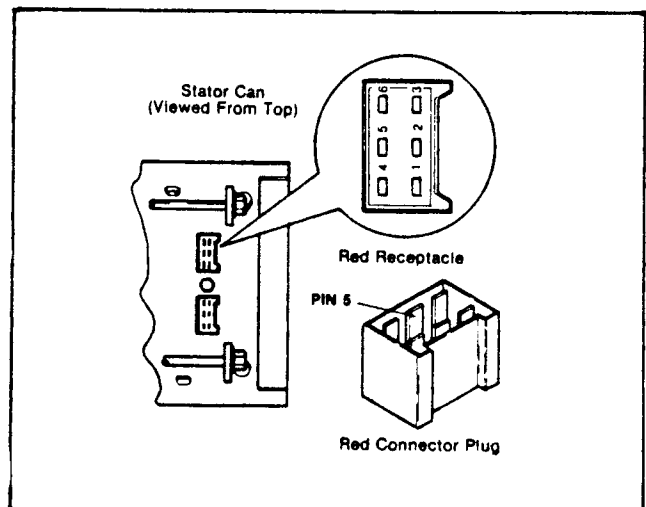

B.)-Set VOM to "+DC" and to any scale that will permit 12 Volts to be read. Connect the positive meter test probe to the Wire No. 4 connection at Field Boost Module. Connect the common (-) test probe to frame ground. Depress the Fuel Pump button- the meter should indicate 9-12 Volts DC.

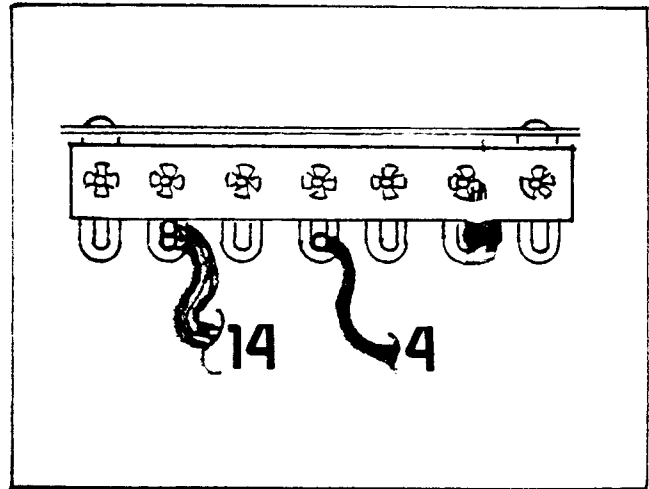

RESULT:-No voltage indicated.....Go to Paragraph C
 Voltage is indicated, but noneRepair/replace Wire No. 4
 in Paragraph A between red receptacle and Field
 Boost Module

C.)-Set VOM to "+DC" and to any scale that will permit 12 Volts DC to be read. Connect the positive (+) meter test probe to the Wire No. 14 connection at Field Boost Module. Connect the common (-) test probe to frame ground. Depress the Fuel Pump button. Meter needle should indicate 9-12 Volts DC.

RESULT:-Normal DC voltage indicated.....Replace Field Boost Module
 but not in Paragraph B
 No voltage indicated.....Check Wire No. 14 between
 the Field Boost Module and the
 Control Relay (CR)

PART III DISASSEMBLY & REPAIR

Section 3.1 - BLOWER SHROUD SECTION

3.1.1 - Disassembly

3.1.2 - Inspection and Repair

3.1.3 - Reassembly

Section 3.2 - ALTERNATOR SECTION

3.2.1 - Disassembly

3.2.2 - Inspection and Repair

3.2.3 - Reassembly

Section 3.3 - ENGINE SECTION

3.3.1 - Disassembly

3.3.2 - Inspection and Repair

3.3.3 - Reassembly

SECTION 3.1
BLOWER SHROUD SECTION

3.1.1- DISASSEMBLY

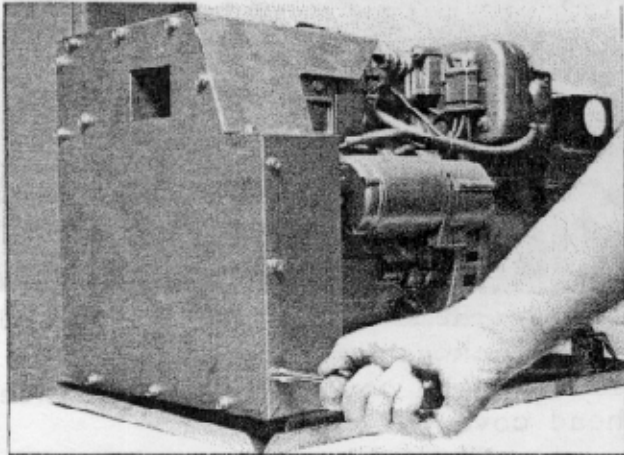

3.1.1.1-Use a 5/16 inch nut driver to remove screws and flat washers that retain blower shroud end panel. Remove end panel.

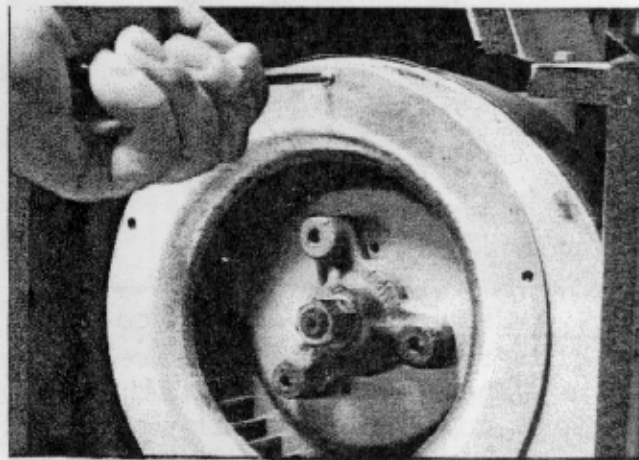

3.1.1.2-Remove Phillips head screws that retain blower inlet ring. Remove blower inlet ring.

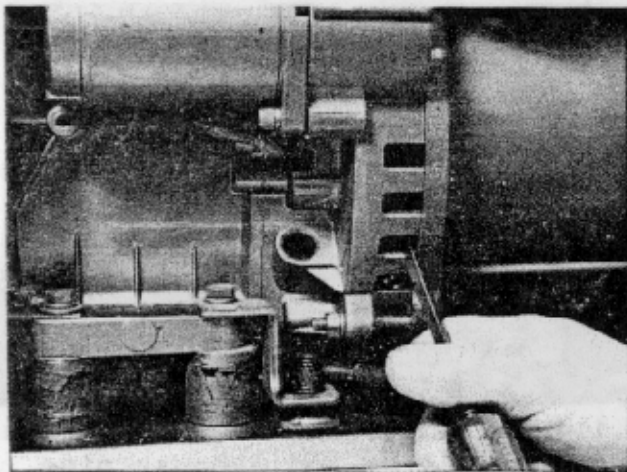

3.1.1.3-Insert a screwdriver into a cooling air slot of engine adapter housing to prevent ring gear from turning.

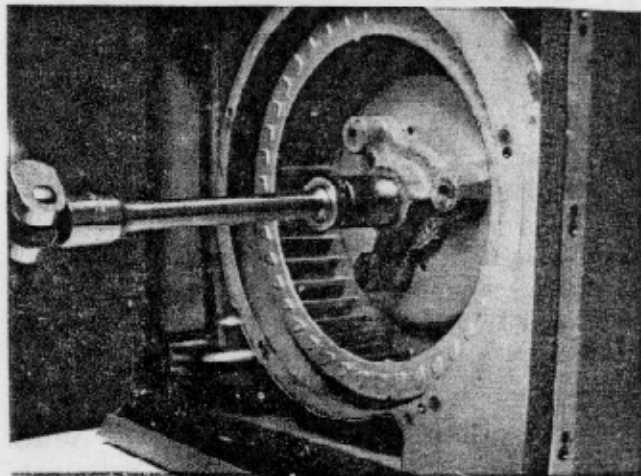

3.1.1.4-While preventing ring gear from turning, remove the special M-14 hex nut that retains the blower fan hub to engine taper shaft.

3.1.1.5-Install three 5/16-24 bolts into threaded holes of blower fan hub. Install a puller as shown at right and pull blower fan and blower fan hub free of engine taper shaft.

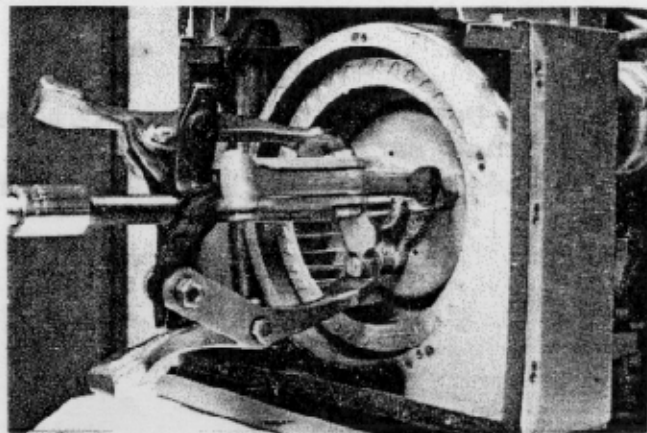

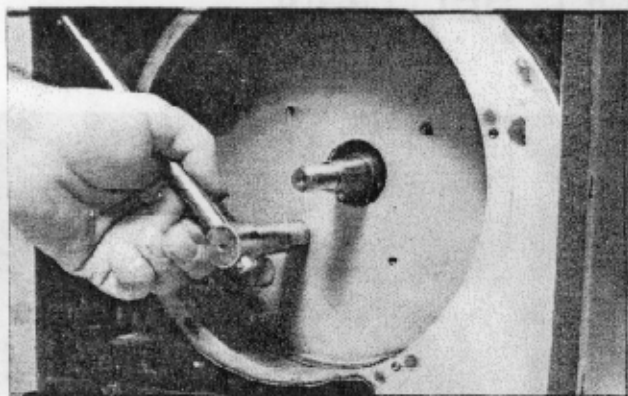

3.1.1.6-Use a 10 mm wrench to remove blower scroll bolts nearest the engine taper shaft. The bolt at lower right corner of blower scroll extends through the shrouding and is retained by a lock washer, flatwasher and hex nut on shroud exterior. Use a 7/16 inch wrench to remove the bolt and nut.

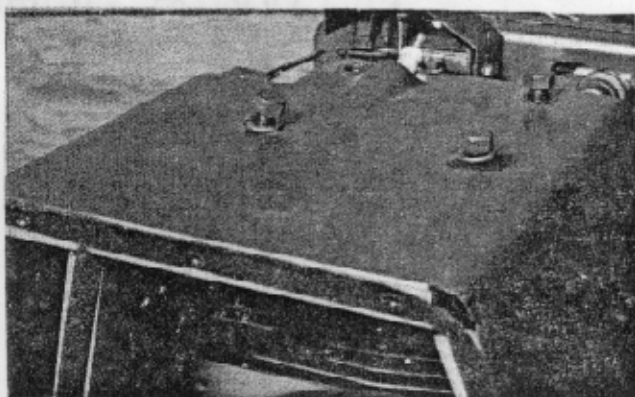

3.1.1.7-Remove four M10 bolts and four lockwashers that retain the cylinder head cover. Remove cylinder head cover.

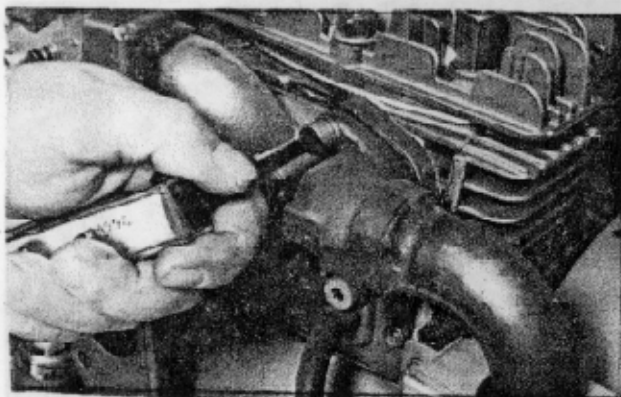

3.1.1.8-Remove two M8 socket head cap screws that retain the exhaust pipe to engine.

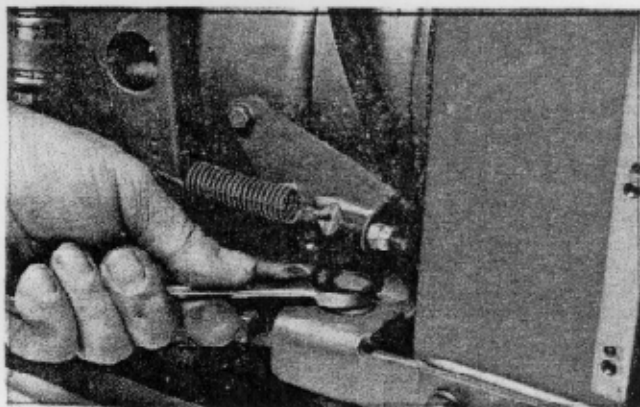

3.1.1.9-Remove bolt and washer that retains housing and exhaust pipe support to vibration dampener.

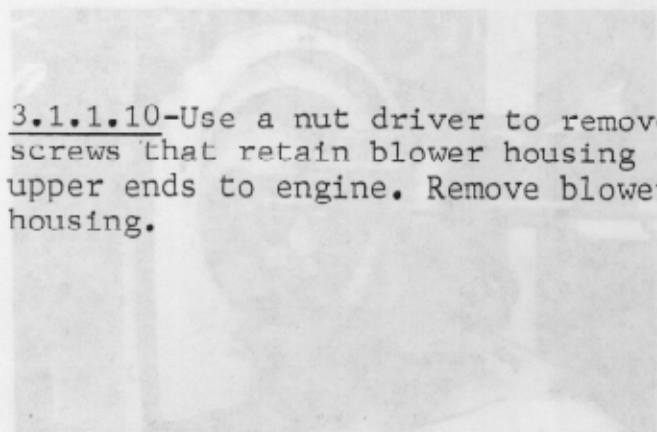

3.1.1.10-Use a nut driver to remove screws that retain blower housing upper ends to engine. Remove blower housing.

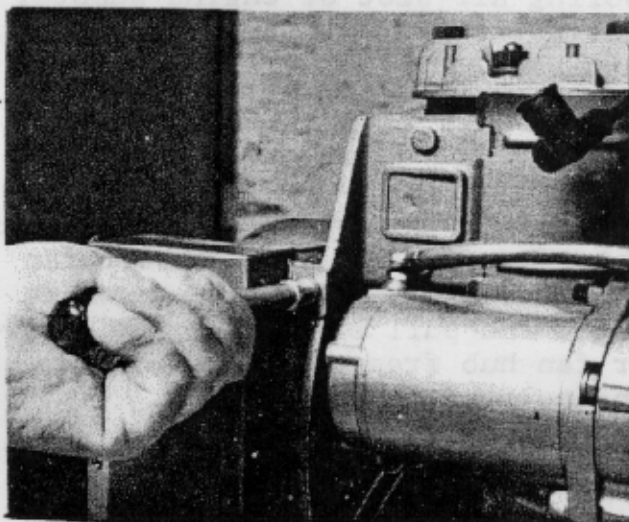

3.1.2-INSPECTION AND REPAIR

Clean and degrease all components, including sheet metal. Inspect all parts as follows:-

- 1.)- Carefully check all sheet metal for cracks or other damage. Repair or replace damaged sheet metal.
- 2.)- Inspect all weld nuts.
- 3.)- Check foam rubber gaskets on blower shroud sheet metal. Replace all damaged strips.
- 4.)- Inspect blower fan for cracks or other damage. Replace, if damaged.
- 5.)- Inspect blower fan hub. Replace, if cracked or damaged or if keyway is worn. Also check key and keyway on engine taper shaft.

3.1.3- REASSEMBLY

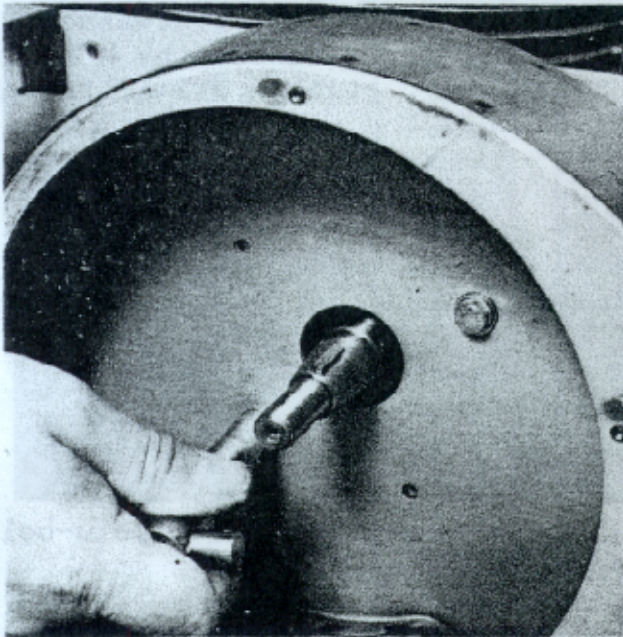

3.1.3.1-Retain blower shroud and blower scroll to cylinder block with two M5 x 10 mm capscrews and lockwashers. Tighten capscrews to 90-110 inch-pounds.

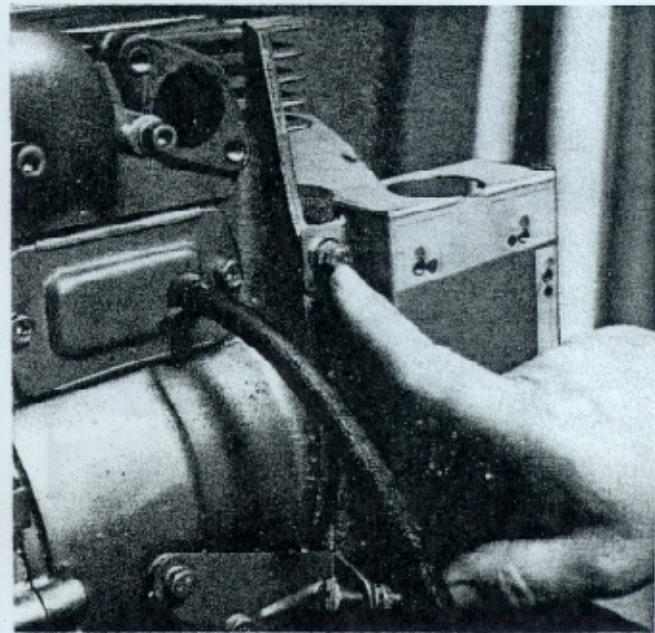

3.1.3.2-Retain blower shroud at both sides of cylinder block with M6 x 15 mm long capscrews, lockwashers and flatwashers.

3.1.3.3-With exhaust pipe u-bolt and housing and exhaust pipe support loosely retained by 2 hex nuts, lockwashers and flatwashers, retain housing and exhaust pipe support to engine base and vibration damper.

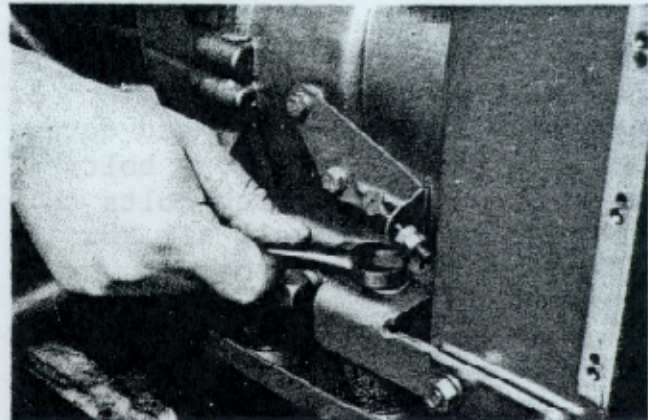

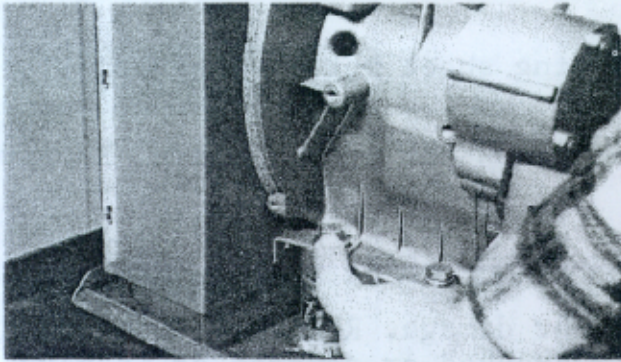

3.1.3.4-Loosely retain blower housing support to opposite vibration damper with capscrew, lockwasher and flatwasher.

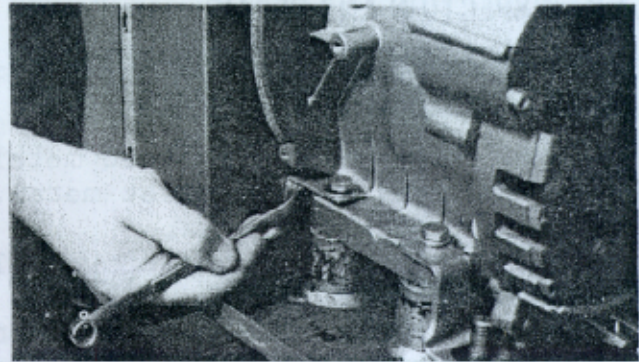

3.1.3.5-Retain blower housing and scroll to blower housing support (installed in previous step) with $\frac{1}{2}$ -20 x $\frac{1}{2}$ inch long bolt and flatwasher and a hex nut, flatwasher and lockwasher. Tighten the hex nut. Finally, tighten all bolts that thread into the vibration dampers.

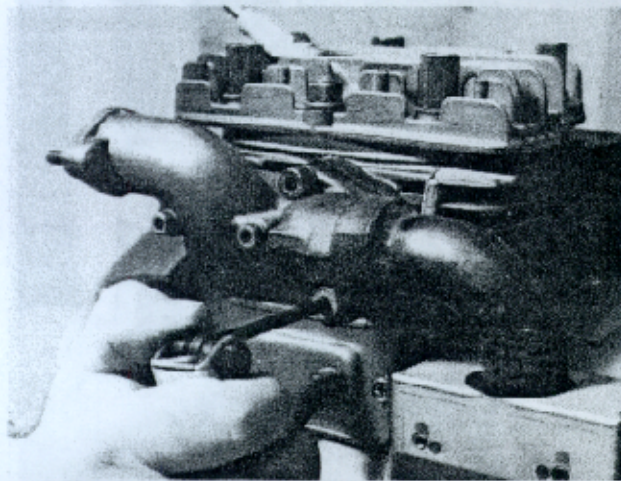

3.1.3.6-Slide exhaust pipe down through blower housing and through exhaust pipe u-bolt. Install exhaust flange gasket. Retain exhaust pipe to exhaust flange with an M8 x 50 mm long and an M8 x 20 mm long socket head capscrew and lockwashers.

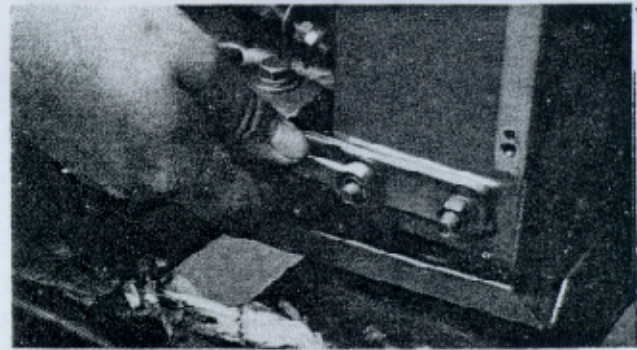

3.1.3.7-Tighten exhaust pipe u-bolt hex nuts.

3.1.3.8-Retain cylinder head cover with four M10 x 20 mm long bolts and lockwashers. Tighten bolts to 12 foot-pounds. Install all No. 10-32 screws that retain head cover to blower housing.

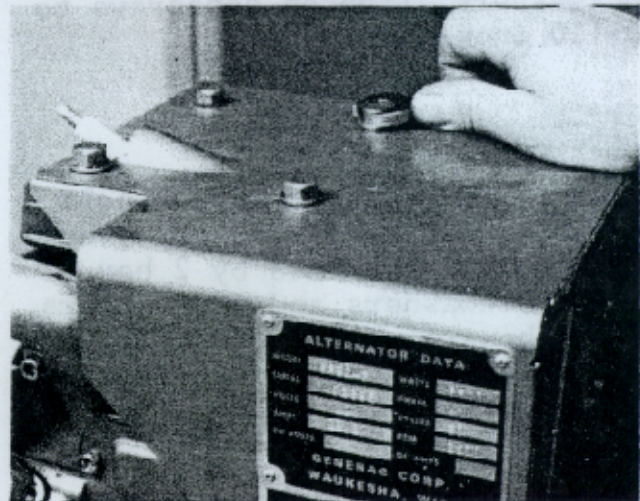

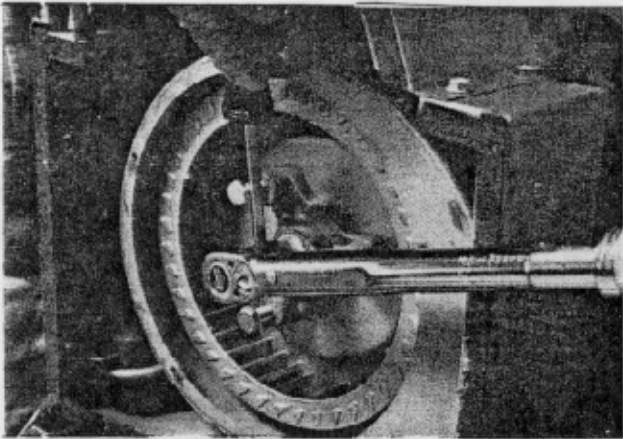

3.1.3.9-Align keyway in blower fan hub with drive key on engine shaft. Install blower fan over engine shaft. Make sure drive key and keyway are engaged. Install special M-14 hex nut and flatwasher. Prevent crankshaft from turning, then torque hex nut to 50-55 foot-pounds.

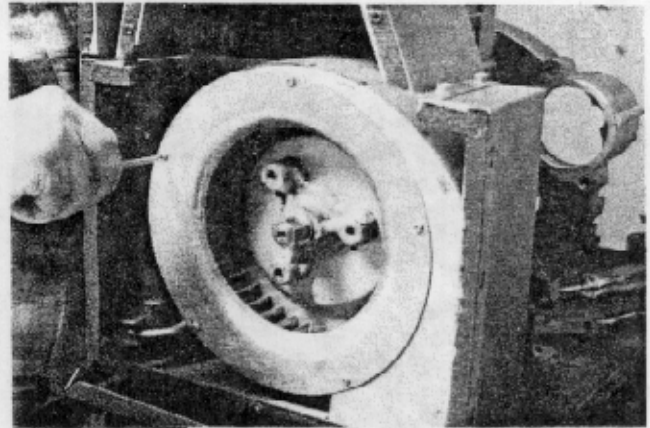

3.1.3.10-Install inlet ring as shown. Retain with No. 6-32 x 3/8 inch long screws and lock-washers.

3.1.3.11-Install blower shroud end panel. Retain with No. 10-32 screws and flatwashers.

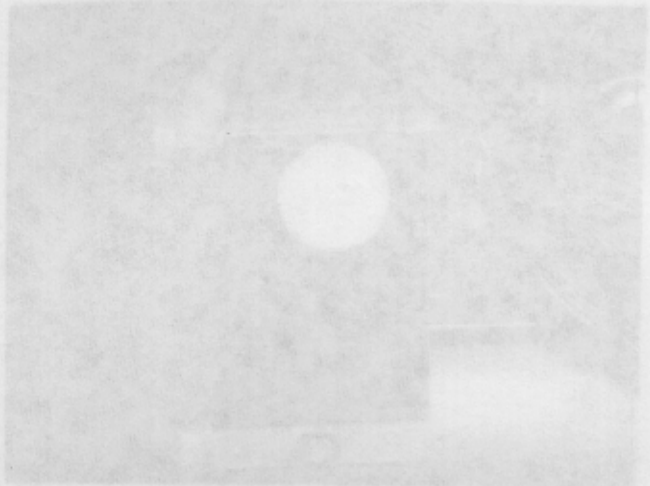
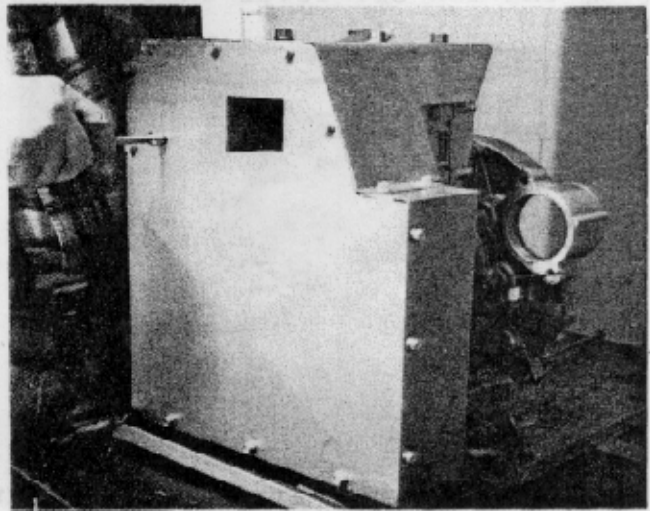

SECTION 3.2
ALTERNATOR SECTION

3.2.1- DISASSEMBLY

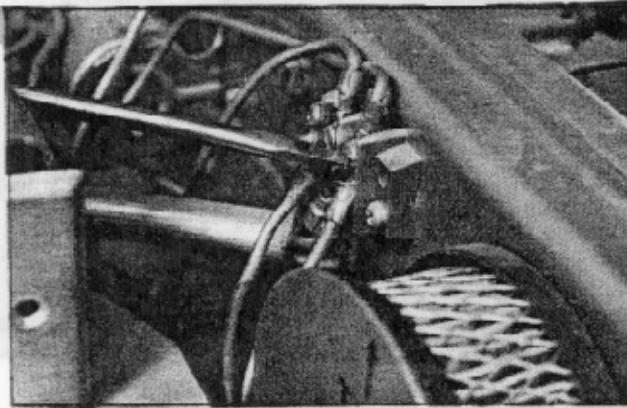

3.2.1.1-At the terminal strip, disconnect the Wire No. 20 that comes from the low oil level shutdown switch.

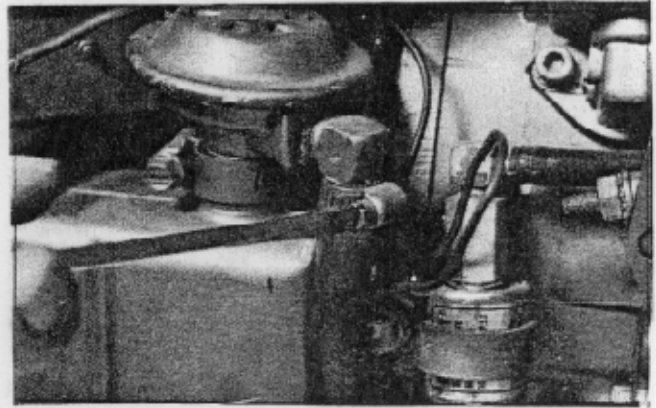

3.2.1.2-Loosen oil line clamp at oil make-up pump. Slide clamp down hose, then disconnect hose from pump fitting.

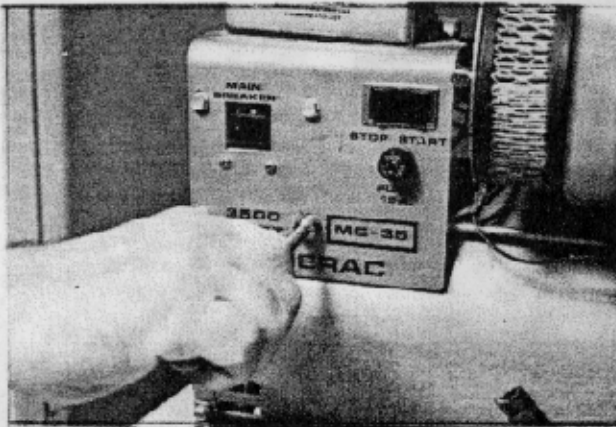

3.2.1.3-Remove 4 screws that retain front panel. Remove front panel.

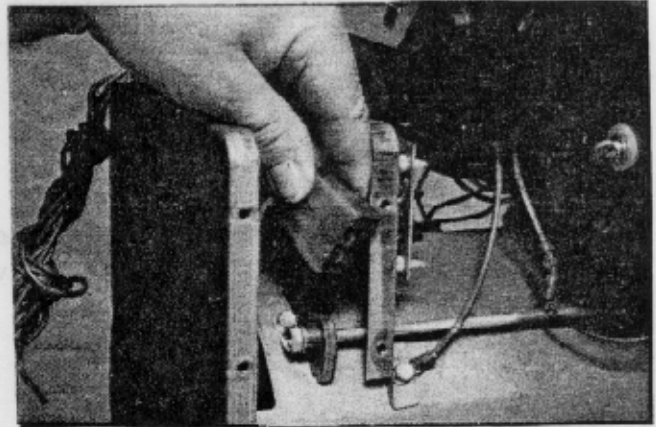

3.2.1.4-Unplug the red connector plug from its stator can receptacle. Also remove ground wire, retained by panel divider screw.

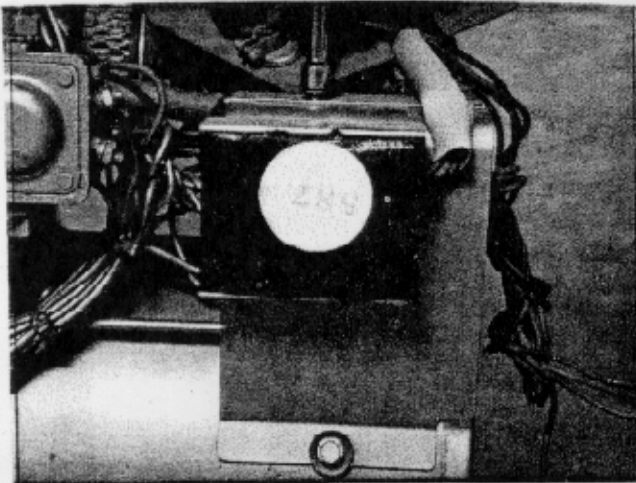

3.2.1.5-Remove screws that retain rear panel. Remove rear panel.

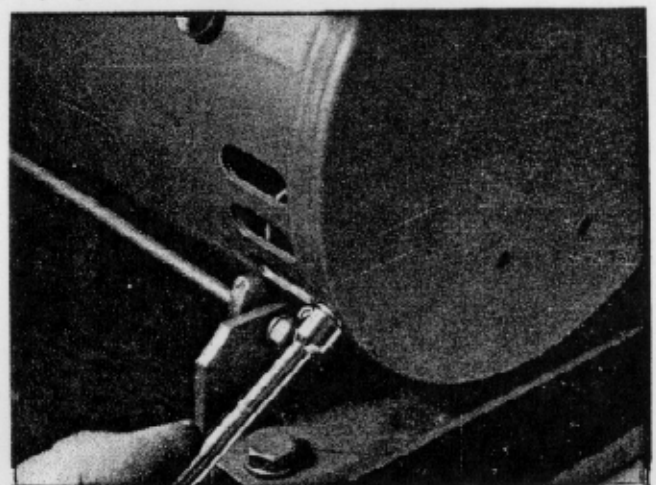

3.2.1.6-Remove end panel.

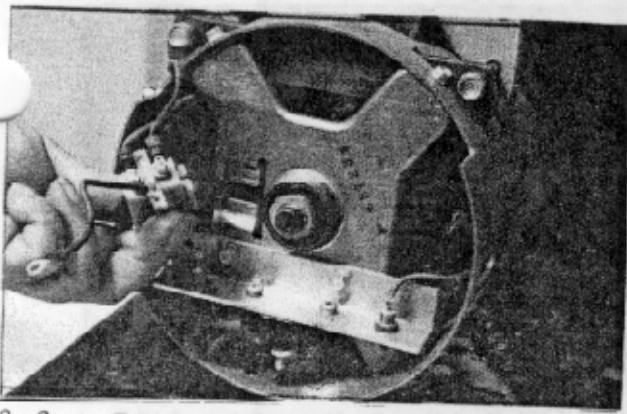

3.2.1.7-Straighten brush holder locking tangs on bearing carrier. Remove brush holder from carrier. Remove brush leads from brushes and remove brush holder and brushes.

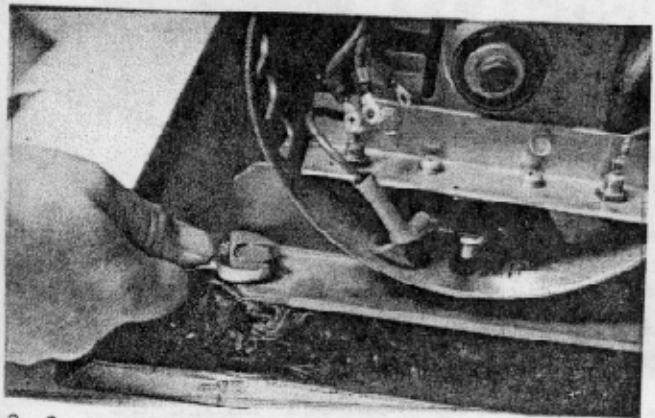

3.2.1.8-Remove alternator support to vibration dampener bolts.

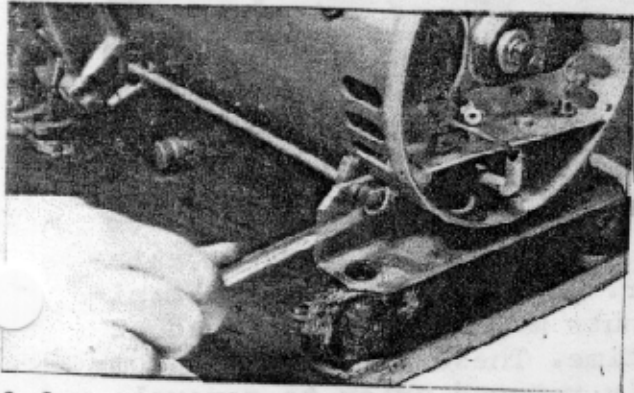

3.2.1.9-Remove two bottom stator bolts and stator bolt bar.

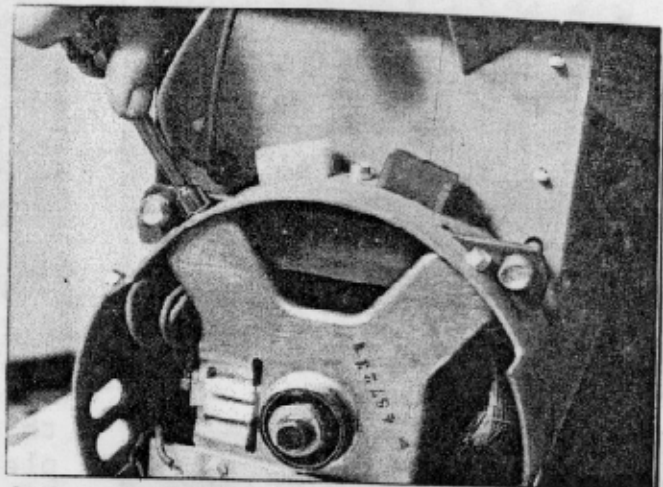

3.2.1.10-Remove 4 screws that retain bearing carrier to stator can. Remove bearing carrier, using a puller.

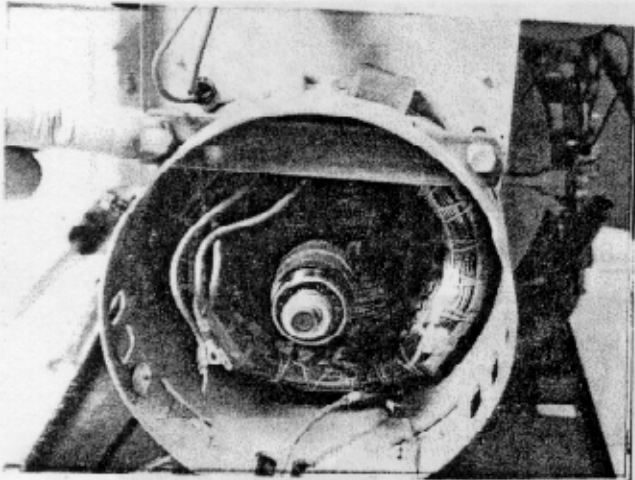

3.2.1.11-Remove 2 upper stator bolts and stator bolt bar.

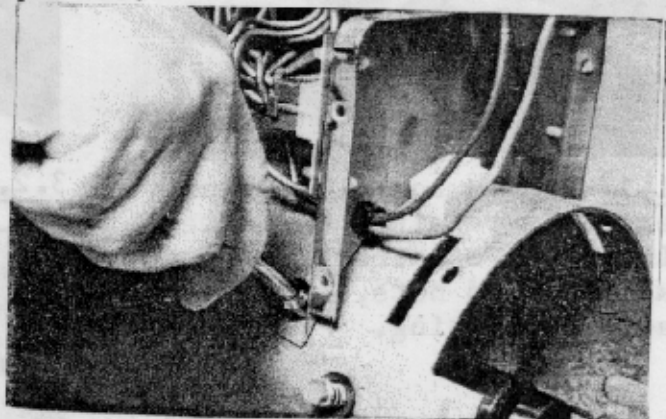

3.2.1.12-Remove panel divider. The stator can may now be removed as well.

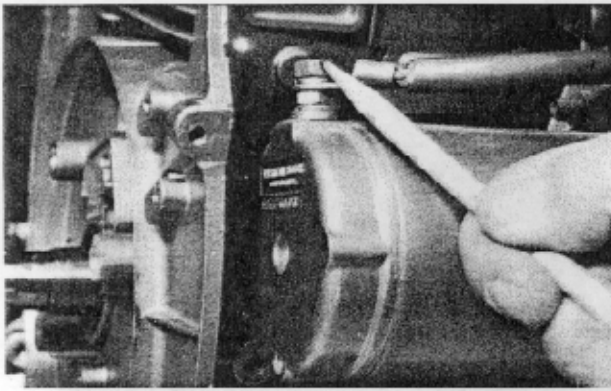

3.2.1.13-Remove starter cable at the starter terminal.

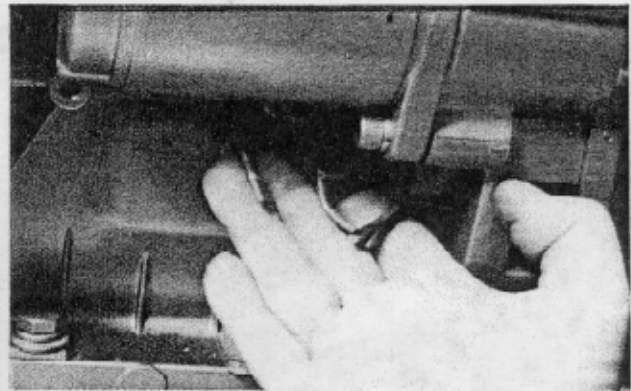

3.2.1.14-Cut Wires No. 8 and 25 that go to the ignition stator.

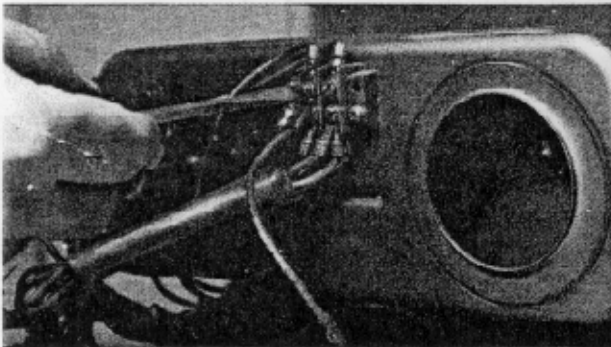

3.2.1.15-At the terminal strip, disconnect the wire from the fuel lockoff solenoid.

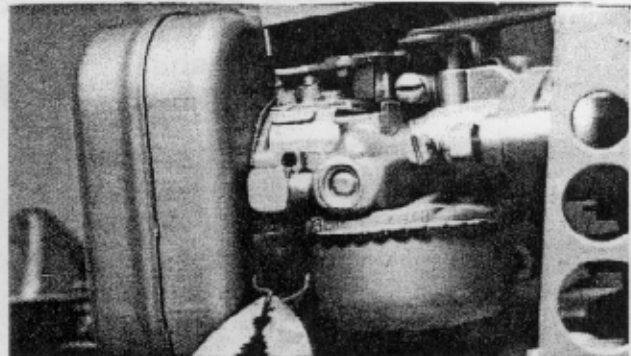

3.2.1.16-Remove fuel line at carburetor. Carburetor to intake manifold nuts may also be loosened at this time. These nuts will be completely removed prior to removal of the adapter casting (Step 3.2.1.17).

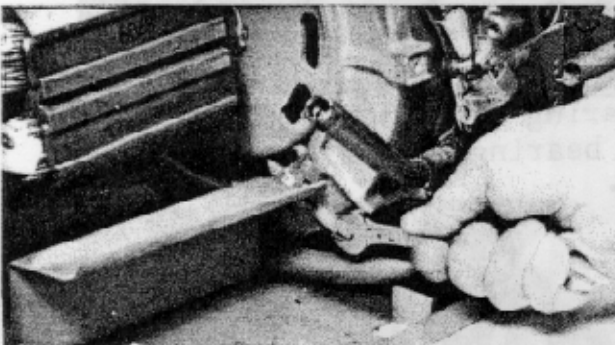

3.2.1.17-Remove bolts, nuts and washers that retain the adapter casting. Remove carburetor to intake manifold nuts, then remove adapter casting.



3.2.1.18-Remove rotor bolt.

3.2.1.19-Use rotor removal kit to remove rotor. (See Section 1.3, SPECIAL TOOLS.) Use the 5/16-24 tap from kit to cut threads in rotor as shown at right.

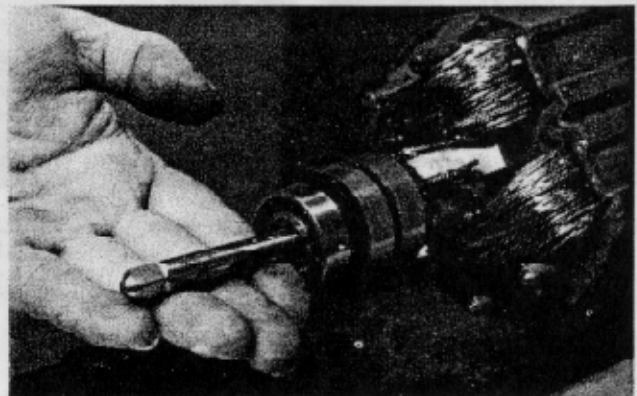

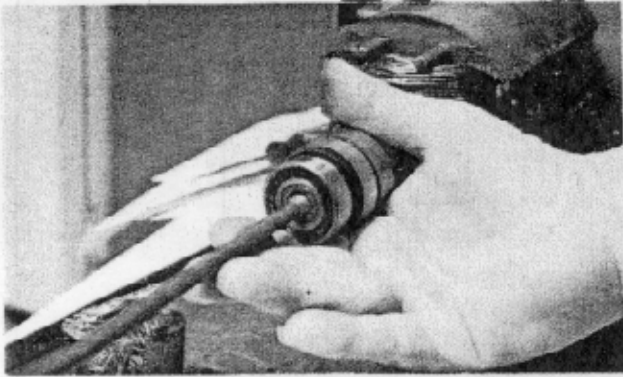

3.2.1.20-Select a stud from the kit that is long enough so that, when the stud is threaded into the engine crankshaft, the slotted end of the stud will extend approximately $\frac{1}{4}$ - $\frac{1}{2}$ inch into the rotor shaft. Thread the stud into the engine crankshaft.

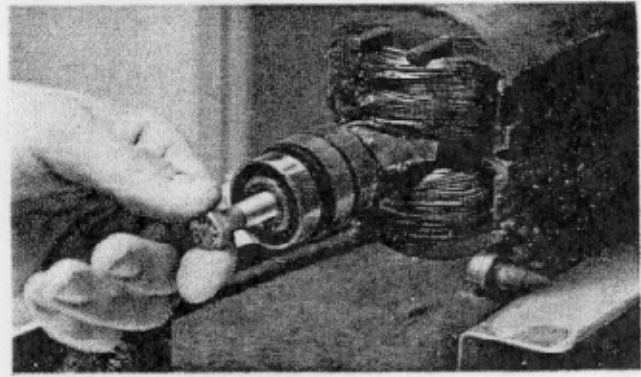

3.2.1.21-Thread the 5/16-24 bolt (included with rotor removal kit) into the rotor shaft until it is firmly seated against the stud. Tighten the bolt against the stud and tap the bolt head with a mallet. Continue tightening and tapping until rotor is free. Remove the rotor and fan assembly.

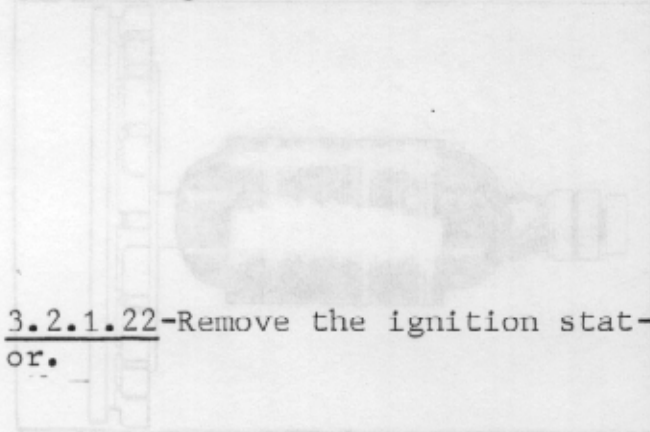

3.2.1.22-Remove the ignition stat- or.

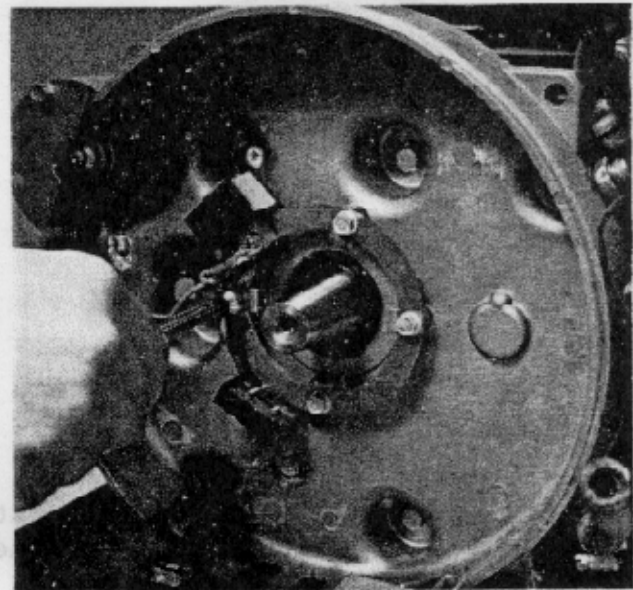

3.2.2- INSPECTION AND REPAIR

3.2.2.1- GENERAL

Inspect wiring for pinching, obvious damage, defective insulation. Clean all parts and inspect for obvious damage, cracks, etc. Check connector plugs and receptacles for damage, pins pushed out of sockets, etc. Repair or replace damaged, defective parts as required.

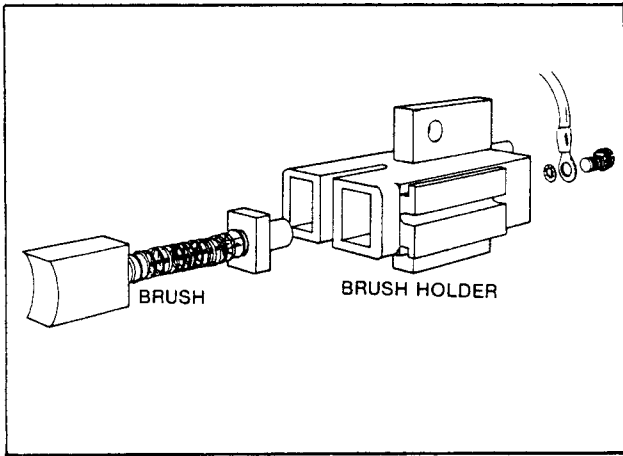

3.2.2.2- BRUSH HOLDER AND BRUSHES

Replace brush holder if cracked or otherwise damaged. Replace brushes if cracked, chipped or less than 5/16 inch long.

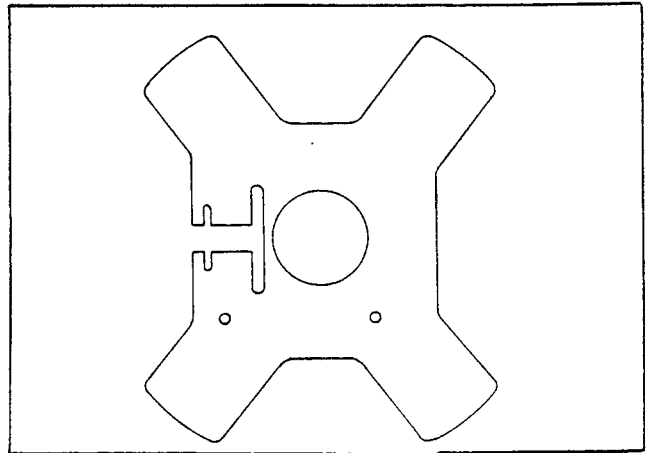

3.2.2.3- BEARING CARRIER

Once removed, the bearing carrier should not be re-used. Replace the bearing carrier during reassembly.

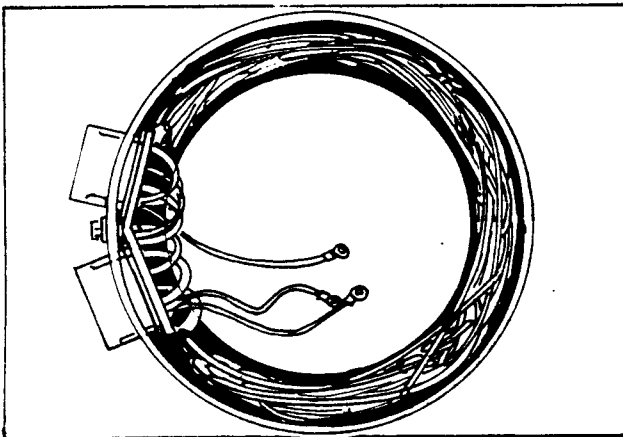

3.2.2.4- STATOR

Inspect closely for damage. Use an insulation breakdown tester and test for breakdown under load. Follow the tester manufacturer's instructions carefully. See 1.1.3, ELECTRICAL TEST SPECIFICATIONS.

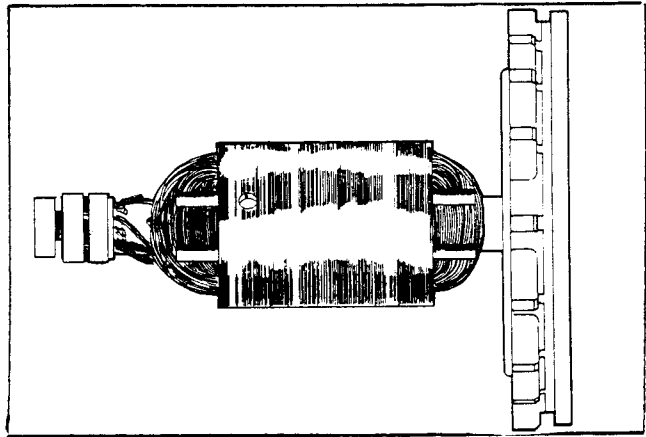

3.2.2.5- ROTOR

Inspect closely for damage. Use an insulation breakdown tester to test for breakdown under load. Follow the tester manufacturer's instructions carefully. See 1.1.3, ELECTRICAL TEST SPECIFICATIONS.

3.2.3- REASSEMBLY

3.2.3.1-During reassembly, torque fasteners as specified in Section 1.1.4, TORQUE SPECIFICATIONS (GENERAL) or 1.1.5, TORQUE SPECIFICATIONS (SPECIAL), as applicable. Do not attempt to re-use worn, defective or damaged parts. The bearing carrier should not be re-used once it has been removed.

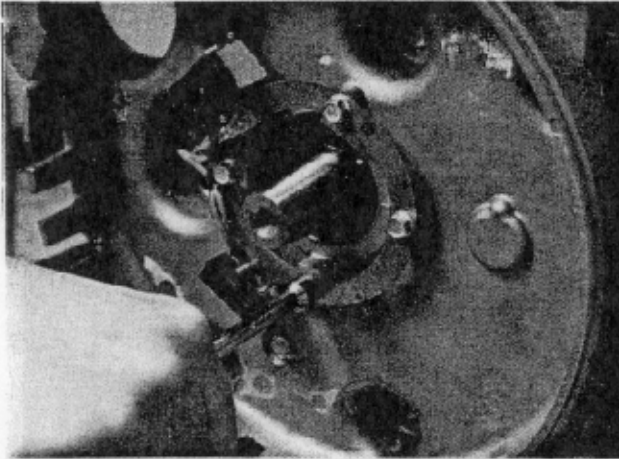

3.2.3.2-Ignition stator mounting holes are offset to make improper installation difficult. Install the ignition stator and retain with No. 10-32 x 3/8 inch screws.

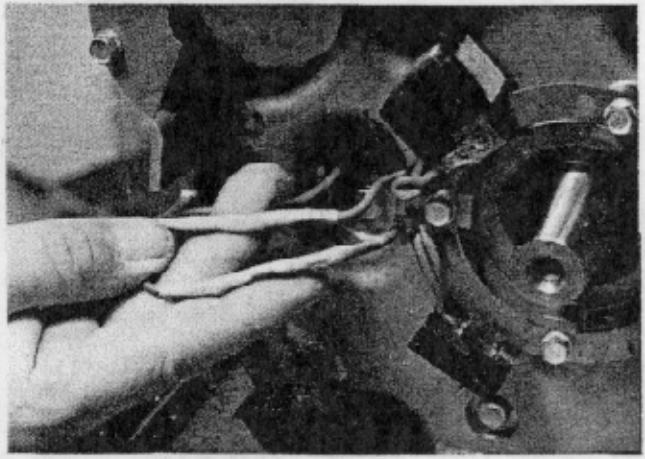

3.2.3.3-Ignition stator wires (No. 8 and 25) were cut during disassembly. If wires are too short for proper splicing after unit is assembled, additional wiring lengths must be added at this time. Above, knife edge connectors were used to add the additional wire length. Heat shrink tubing was then installed and shrunk over the connectors. (NOTE:- Some later production units may be equipped with quick disconnects at these wires for ease of maintenance.)

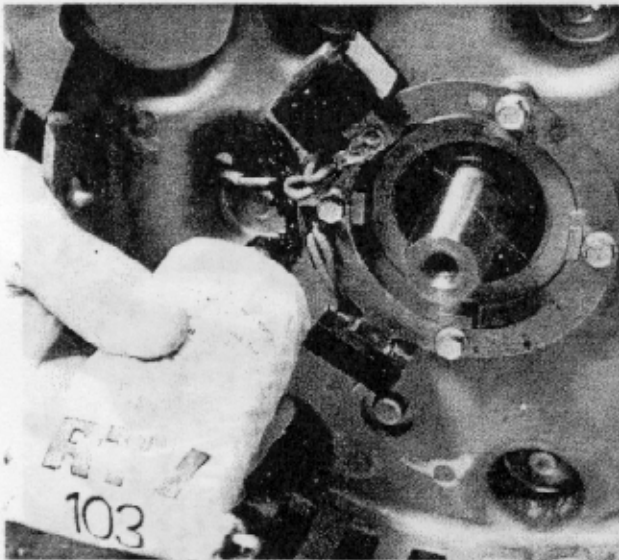

3.2.3.4-Pull both ignition stator wires through the hole provided in the engine gear cover. Retain wires flush against gear cover with RTV-103.

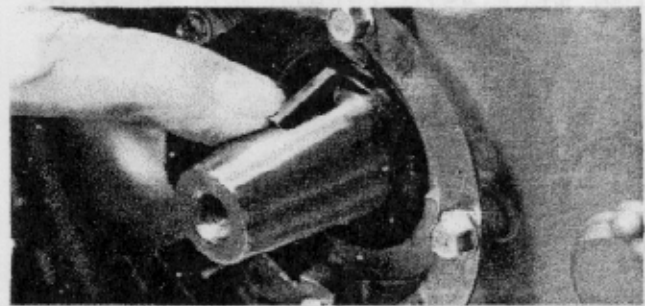

3.2.3.5-Inspect Woodruff key and keyway on engine taper shaft and rotor. Replace key if damaged or worn. Install key into keyway on engine taper shaft.

3.2.3.6-Install rotor. Make sure key and keyway are engaged. Install rotor bolt, lockwasher and 2 flatwashers. Tighten rotor bolt, making sure rotor pulls in as the bolt is tightened. When rotor is tight and will pull in no further, loosen rotor bolt. Then tighten bolt to 15-17 foot-pounds.

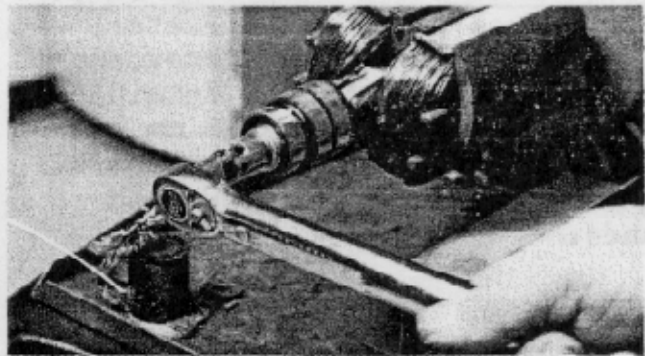

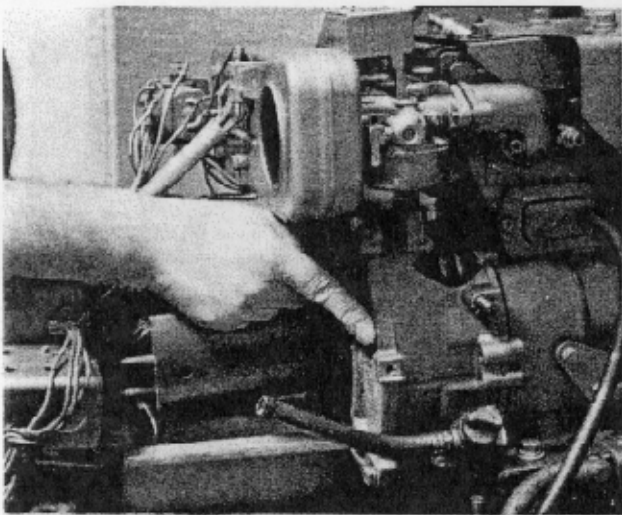

3.2.3.7-Align adapter casting with bolt holes in engine gear cover. Install casting, making sure the carburetor intake manifold studs are aligned with carburetor. At the lower right corner of casting, retain with a 5/16-18 x 2" bolt with square nut. Also retain with two 5/16-18 x 2½" bolts, lockwashers and hex nuts. Upper left corner of casting will be retained by a 5/16-18 x 4" bolt and hex nut, which will also retain the starter.

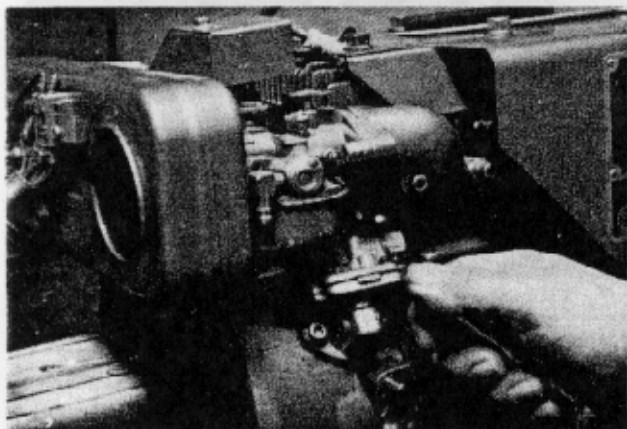

3.2.3.9-Mechanical Fuel Pump Only: Install fuel pump, inlet filter, solenoid shutoff valve, interconnecting hoses and clamps. Retain the fuel pump with two M6 x 18 mm socket head capscrews and lockwashers. Tighten capscrews to 25-30 inch pounds.

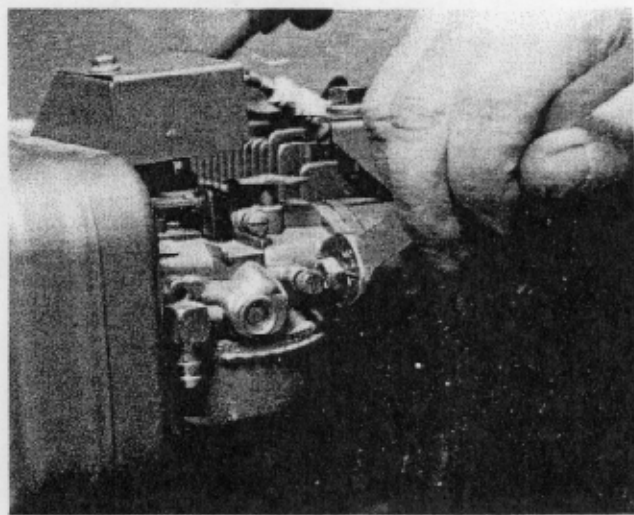

3.2.3.8-Install a new carburetor to intake manifold gasket. Retain carburetor to intake manifold with two ½-20 NyLok nuts.

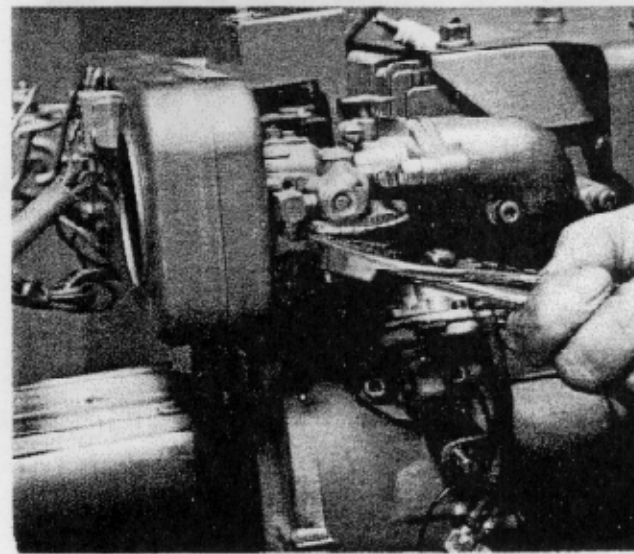

3.2.3.10-The fuel pump to carburetor or fuel line contains a filter screen. Install clamps over fuel line. Then connect line to carburetor inlet fitting and fuel pump outlet fitting. Retain line with clamps.

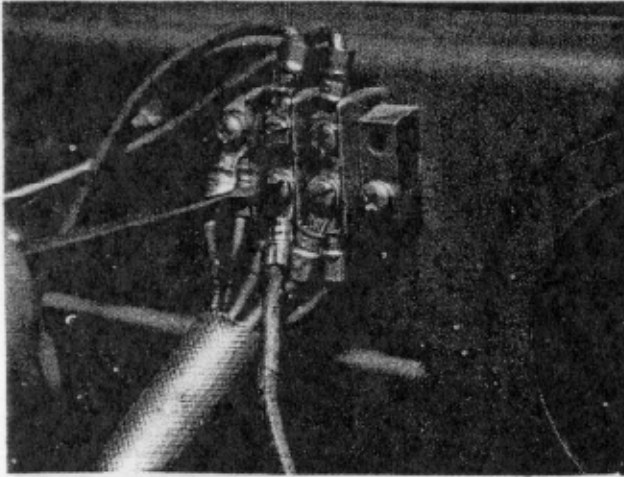

3.2.3.11-Connect Wire No. 14 (the longest wire) from the fuel lock-off solenoid to the terminal strip. Refer to appropriate wiring diagram for wiring connections.

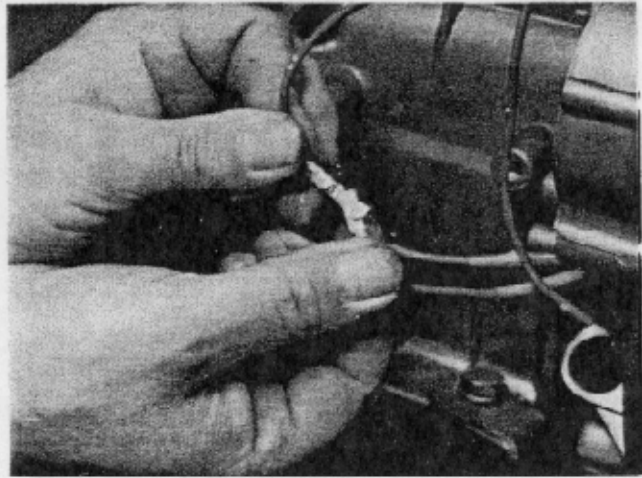

3.2.3.12-Wires No. 8 and 25 from the ignition stator were cut during disassembly. (NOTE:-Some later production units may have a quick disconnect on these wires.) If wires were cut, strip wire ends and install a knife edge connector.

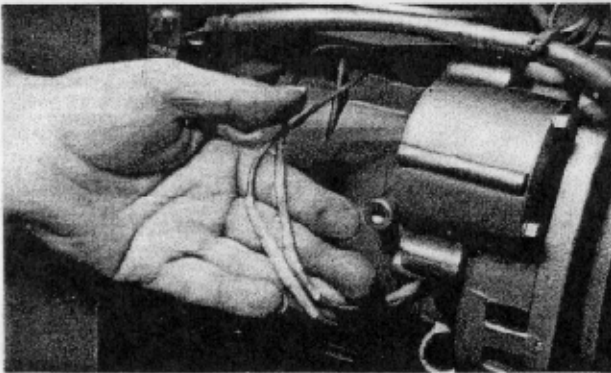

3.2.3.13-Install heat shrink tubing over the connectors on Wires 8 and 25.

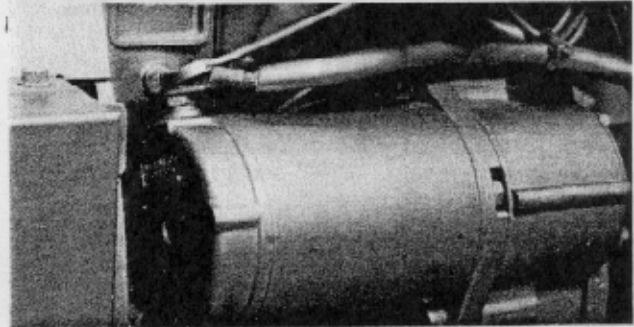

3.2.3.14-Install starter bolt. The upper starter bolt (5/16-18 x 4") passes through starter, engine gear cover and adapter casting. Lower starter bolt is a 5/16-18 x 1" socket head capscrew. Tighten starter bolts, then torque adapter casting bolts (including 4 inch long starter bolt) to 120 inch pounds. Finally, install the starter cable and retain with hex nut and lockwasher.

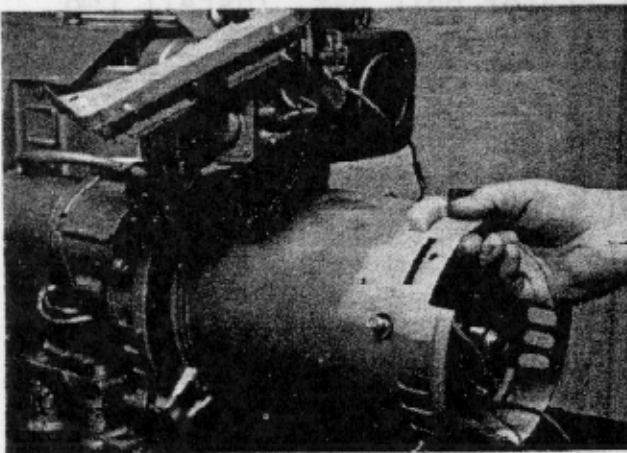

3.2.3.15-Carefully align stator and install over rotor.

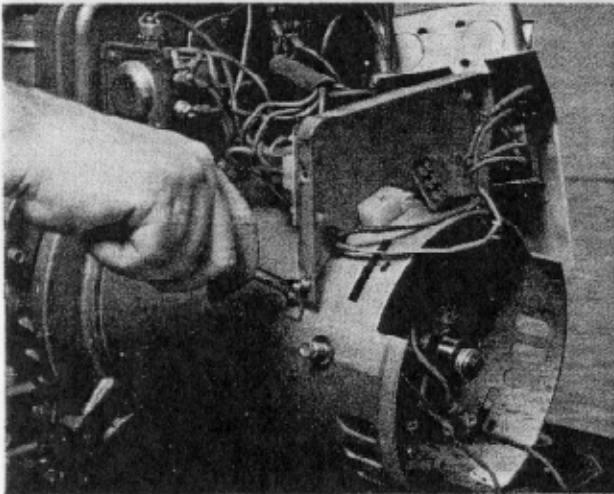

3.2.3.16-Retain panel divider to stator can with two taptite screws. The ground wire (No. 10) previously disconnected from Stop/Start switch terminal connects to one of these screws.

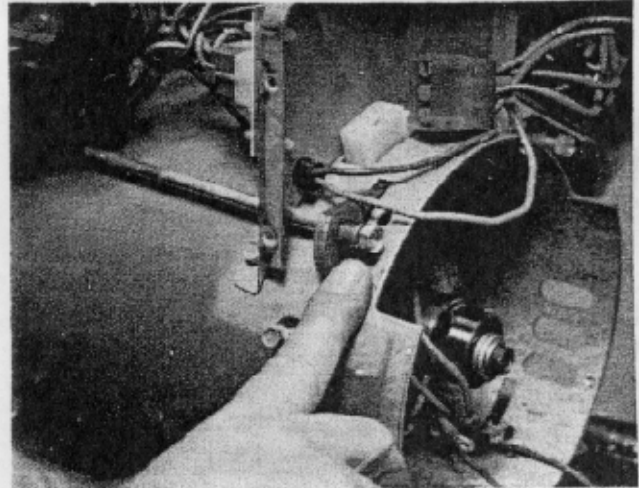

3.2.3.17-Install upper stator bolt bar. Install both upper stator bolts. Only the two upper stator bolts have a spacer. Bolts can be tightened later, after the two lower stator bolts are installed.

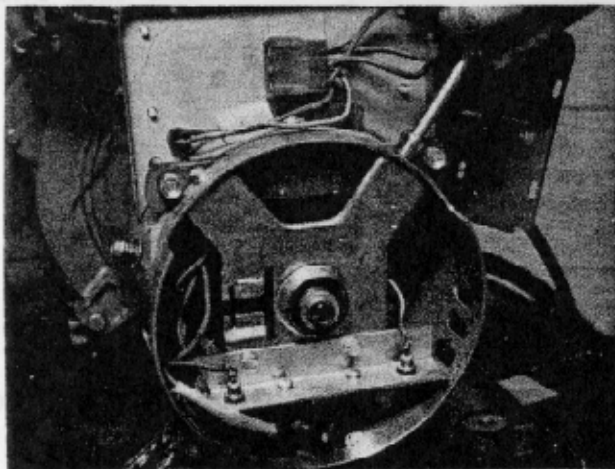

3.2.3.18-Apply a small amount of Loc-Tite to rotor bearing outer diameter. Install a new bearing carrier. Retain carrier to stator can with four No. 10-32 x 3/8" Taptite screws.

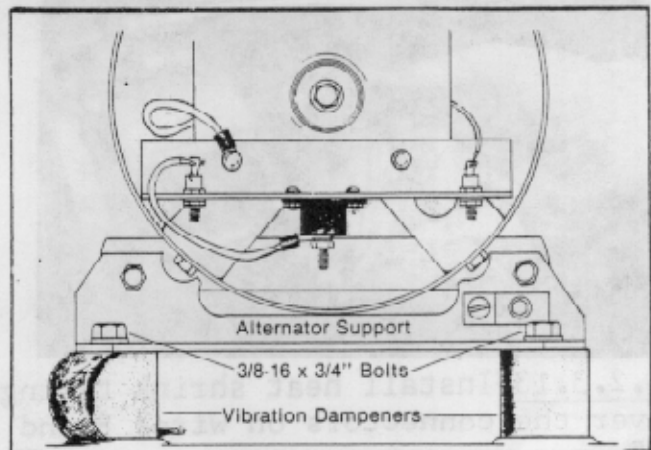

3.2.3.19-Install alternator support onto vibration dampeners. Retain with two 3/8-16 x 3/4" bolts and lockwashers. Install the lower stator bolt bar. Install two lower stator bolts with lockwashers. Tighten all 4 stator bolts. Make sure stator can is flush against adapter casting, then tighten all 4 stator bolts to 80-100 inch pounds.

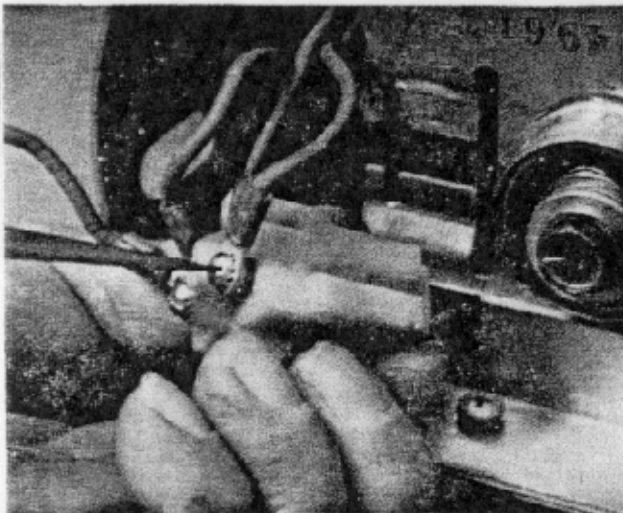

3.2.3.20-Connect 2 red wires (No. 4) to brush that will be nearest the rotor bearing. Retain with a No. 6-32 Sims screw and 2 external lockwashers. Connect 2 ground wires (No. 10) to remaining brush with Sims screw and 2 lockwashers.

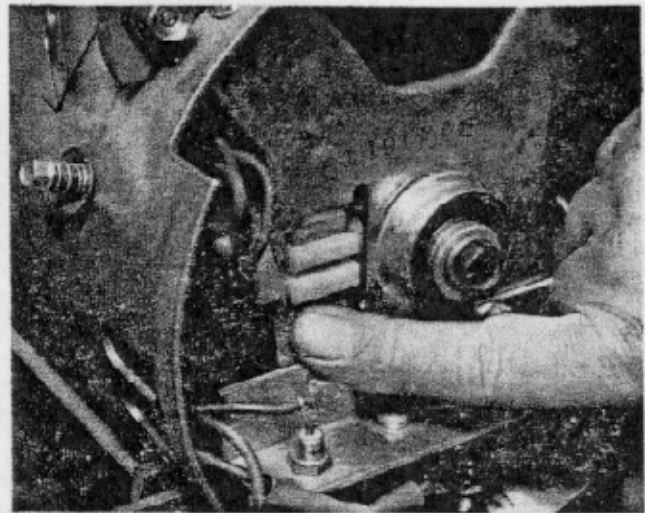

3.2.3.21-Slide brush holder locking grooves over bearing carrier locking tangs. Make sure brushes contact slip rings properly. Bend bearing carrier locking tangs to retain brush holder.

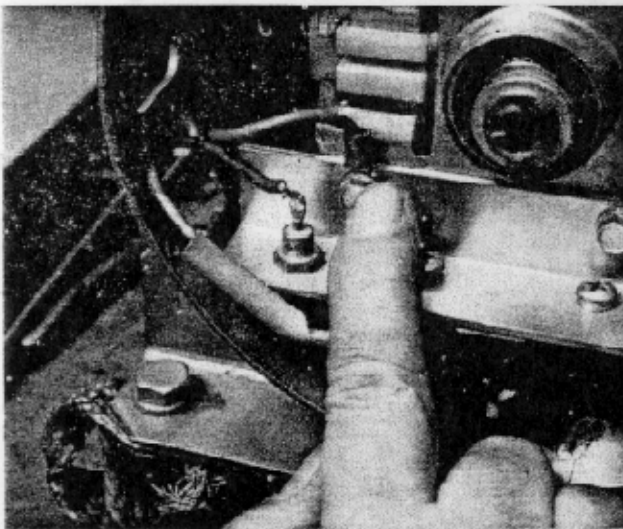

3.2.3.22-Retain brush ground wire (No. 10) to heat sink with heat sink retaining screw.

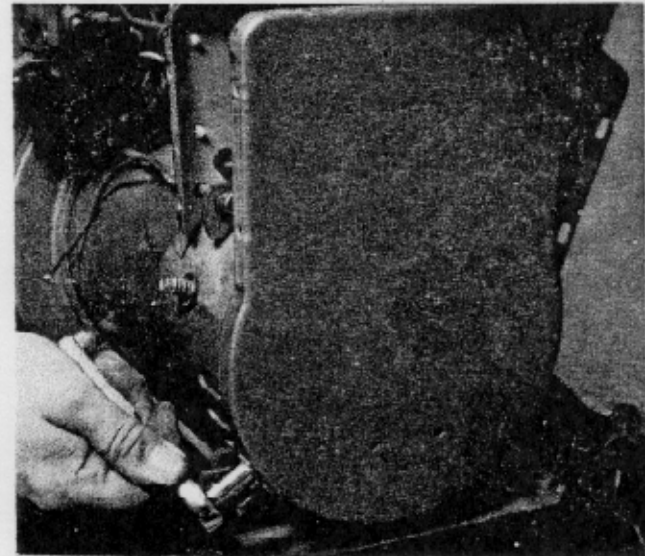

3.2.3.23-Install end panel. Retain to stator can with two No. 10-32 x 3/8" Taptite screws. (A small grounding lug is also retained by one of these screws.)

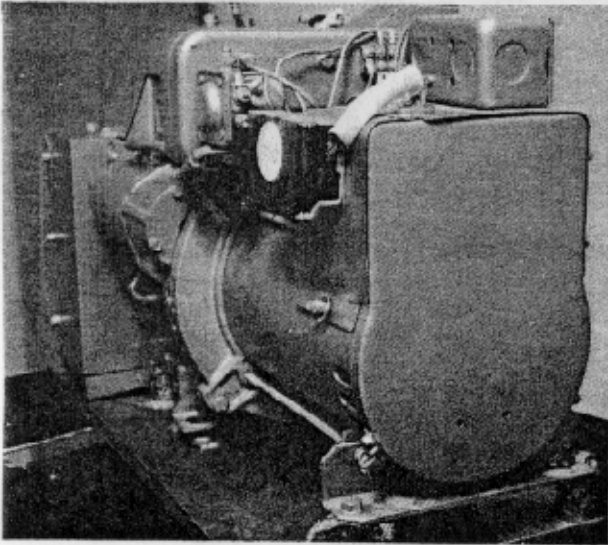

3.2.3.24-Install rear panel with voltage regulator. Connect read and white connector plugs into their receptacles. Install front panel. Connect ground wire (No. 10) to center terminal of stop/start switch.

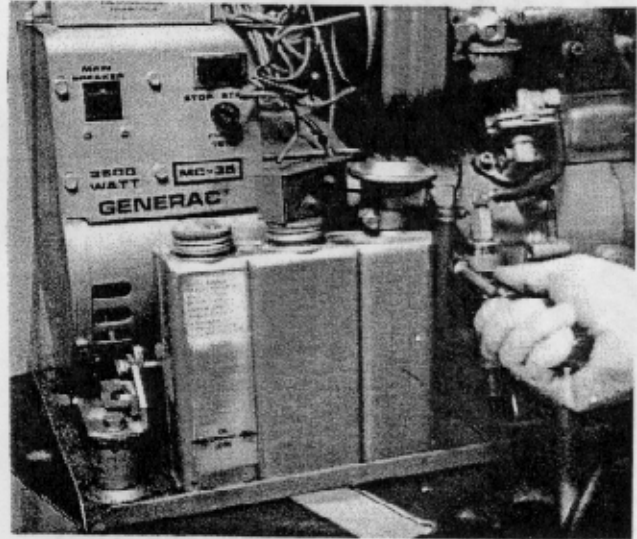

3.2.3.25-Install oil make-up tank with pump. Connect oil lines to pump and probe, retain with clamps. Connect Wire No. 20 from low oil level shutdown switch to terminal strip (see appropriate wiring diagram). Connect ground wire from low oil level shutdown switch and from fuel lockoff solenoid to the tapped hole on adapter casting, along with fuel lockoff solenoid clamp.

3.2.3.23-Install end panel. Retain to stator can with two No. 10-32 x 3/8" Tapelite screws. (A small grounding lug is also retained by one of these screws.)

3.2.3.22-Retain brush ground wire (No. 10) to heat sink with heat sink retaining screw.

SECTION 3.3
ENGINE SECTION

3.3.1- DISASSEMBLY

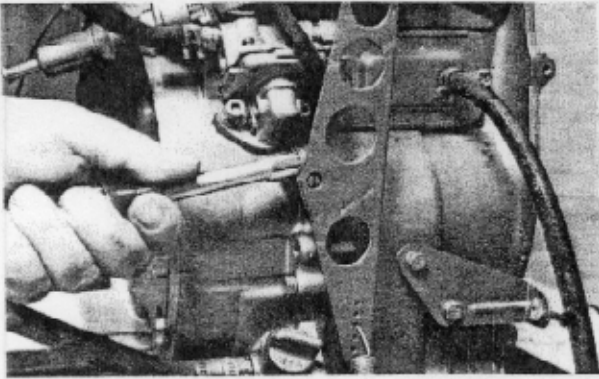

3.3.1.1-Disconnect governor spring from governor adjusting screw. Loosen governor arm clamp bolt and remove governor arm from governor shaft.

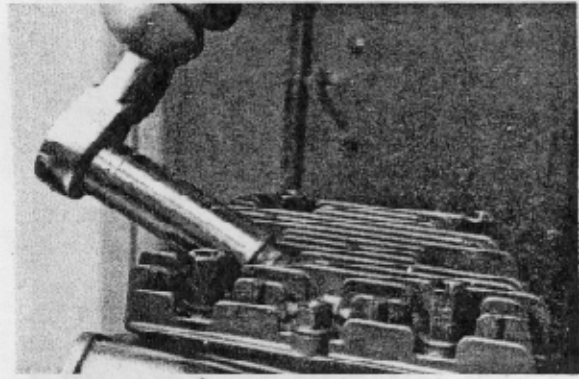

3.3.1.2-Remove spark plug.

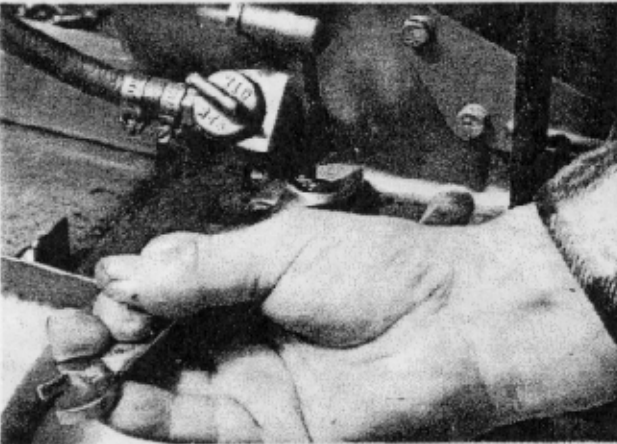

3.3.1.3-Remove engine from alternator slide pan.

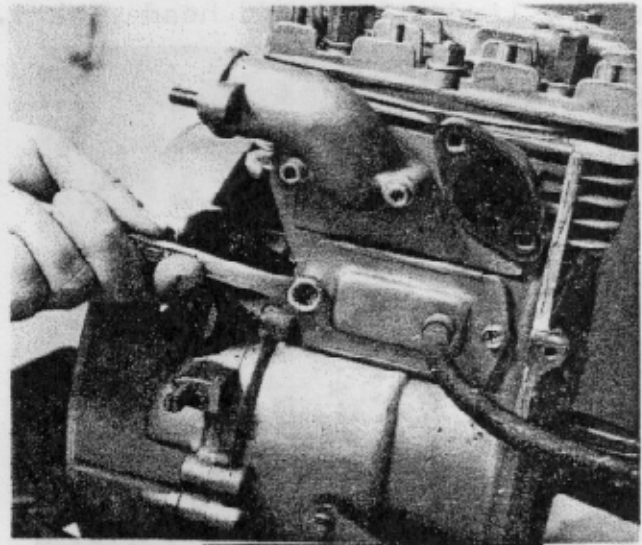

3.3.1.4-Remove breather assembly.

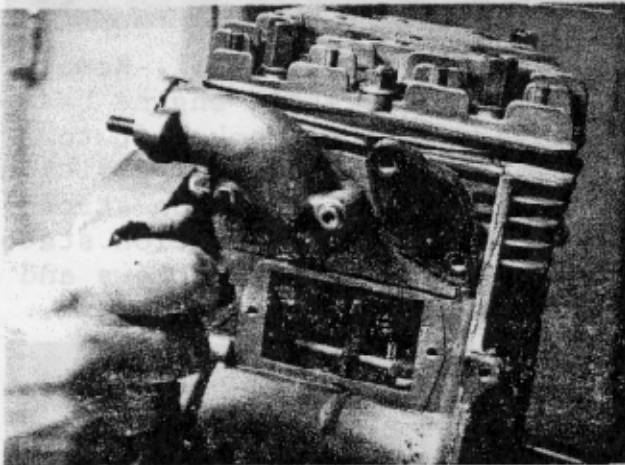

3.3.1.5-Remove intake manifold elbow.

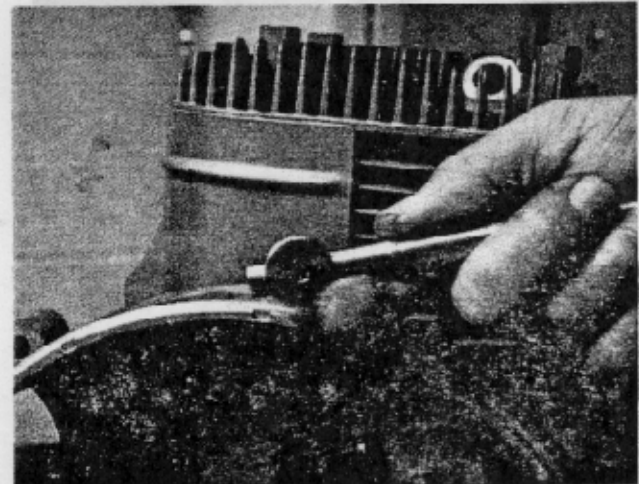

3.3.1.6-Remove engine cowling.

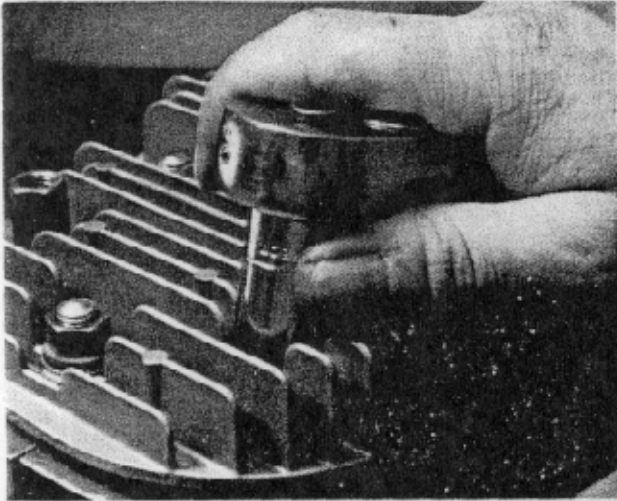

3.3.1.7-Remove 8 cylinder head nuts. Remove cylinder head and head gasket.

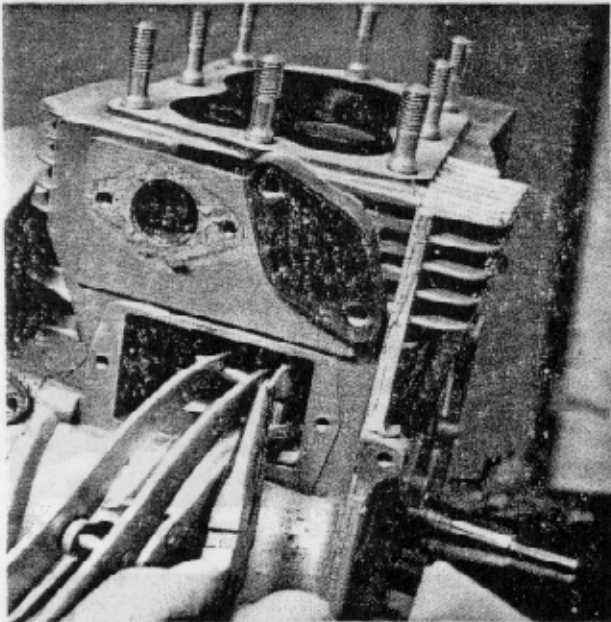

3.3.1.9-Use valve spring compressor to compress valve springs. Then remove roller pin from valve stem. Remove compressor, then remove valve springs, spring retainers and valves.

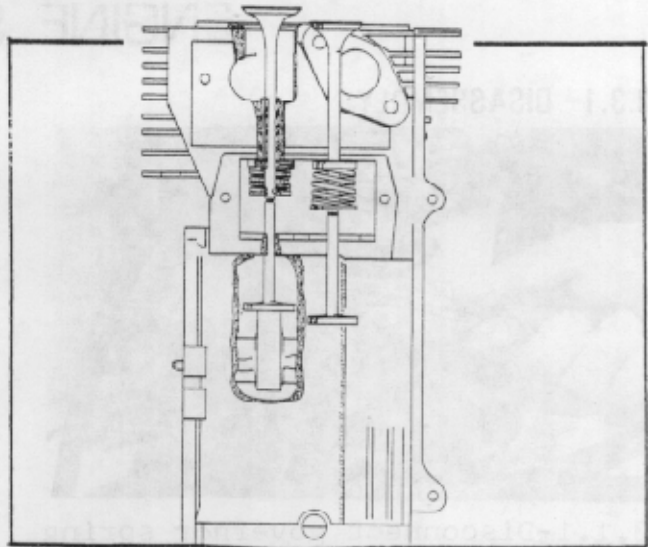

3.3.1.8-Intake and exhaust valves are shown in a sectional view above. Valve springs are retained to valve stems by valve retainers and a roller pin. Keep valve parts together as a set. Intake valve is identified by the letter "I" on

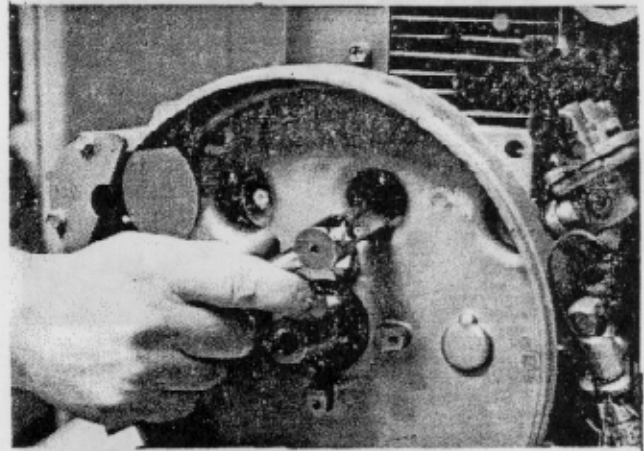

3.3.1.10-Drain engine oil. Remove all bolts that retain engine bearing cover. Rotate crankshaft to place its keyway at 12:00 position (top dead center of piston stroke). Install screws into ignition stator screw holes. Use these screws and a puller to remove bearing cover.



3.3.1.11-Remove thrust washer from end of cam shaft.

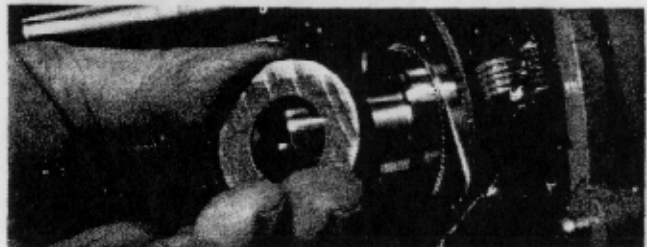

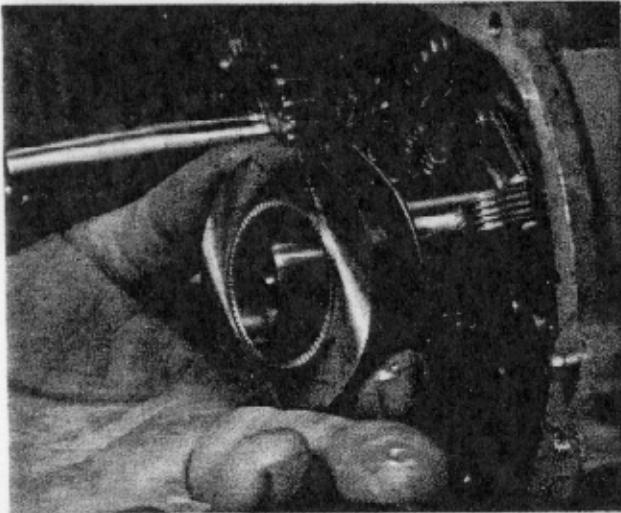

3.3.1.12-Remove governor slider from end of cam shaft.

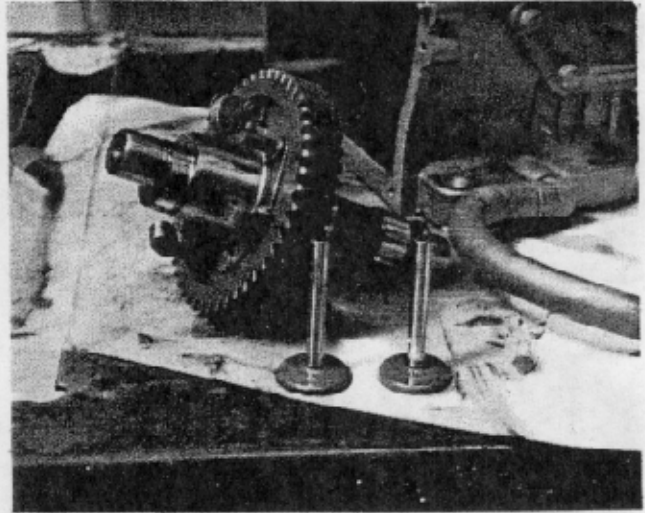

3.3.1.13-Remove cam shaft and valve tappets.

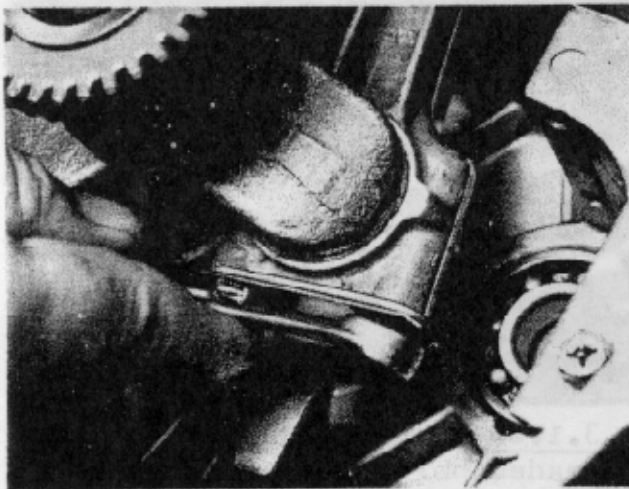

3.3.1.14-Bend lock tab ends away from connecting rod bolt heads. Remove the connecting rod bolts, lock tab, oil splasher and connecting rod lower half. Push piston and connecting rod up through cylinder and remove. Remove crankshaft.

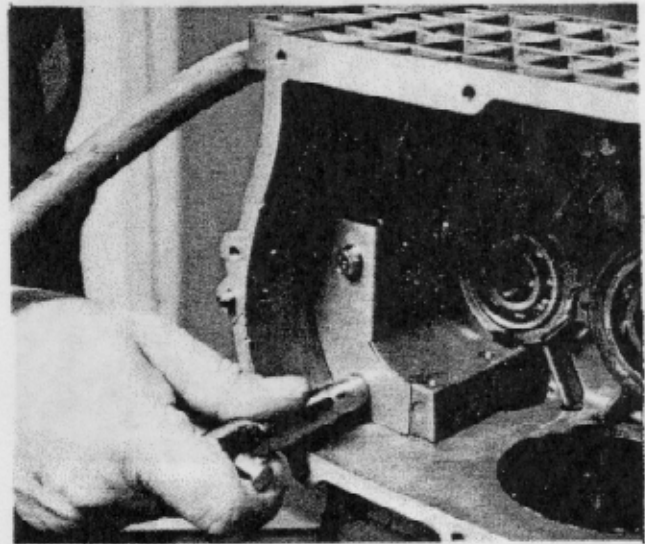

3.3.1.15-Remove oil stopper.

3.3.1.16-It is not necessary to remove bearings unless replacement is necessary. Bearings must be pressed out of cylinder block.

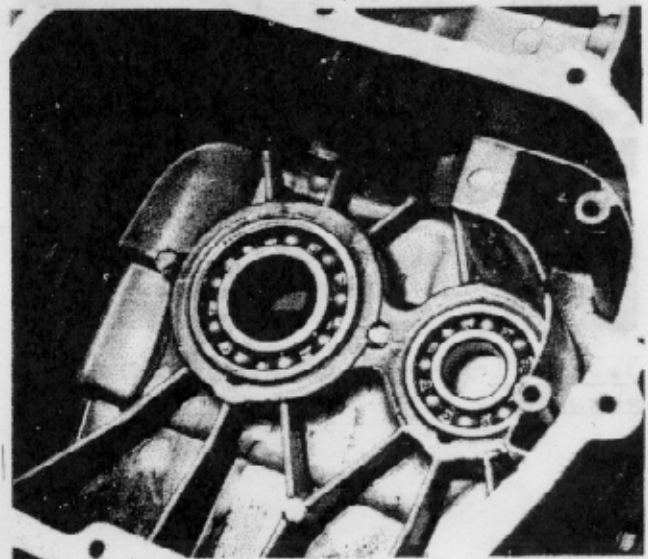

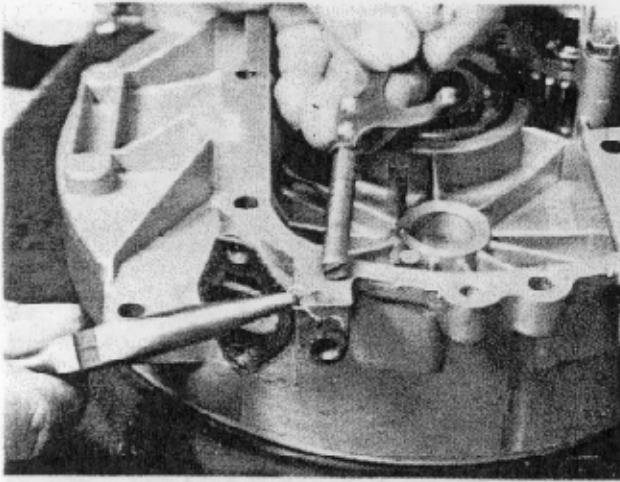

3.3.1.17-Remove governor shaft retaining clip and governor shaft.

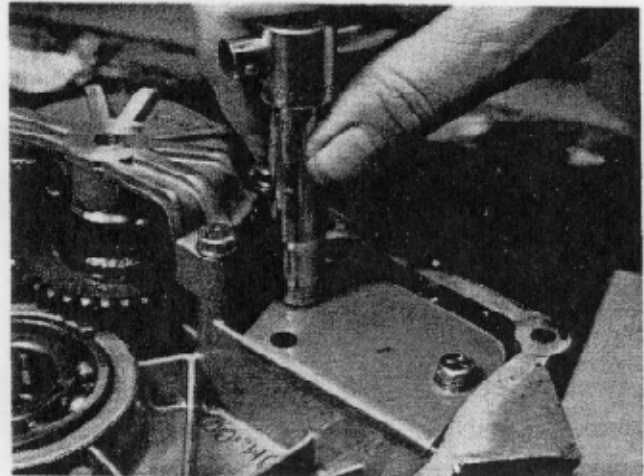

3.3.1.18-Remove oil stopper from engine bearing cover.

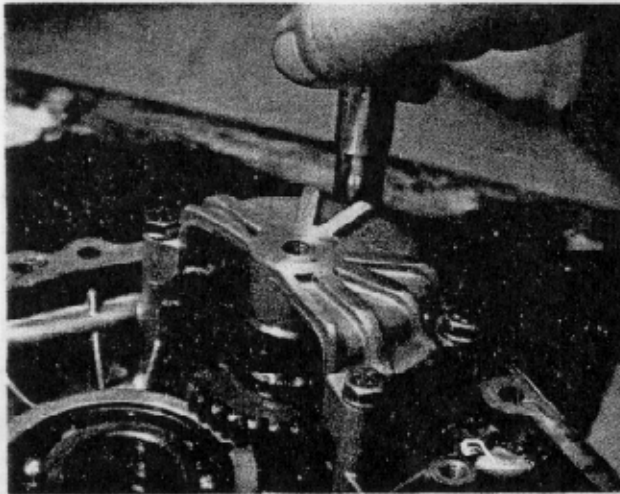

3.3.1.19-Remove bolts that retain counterbalance cover.

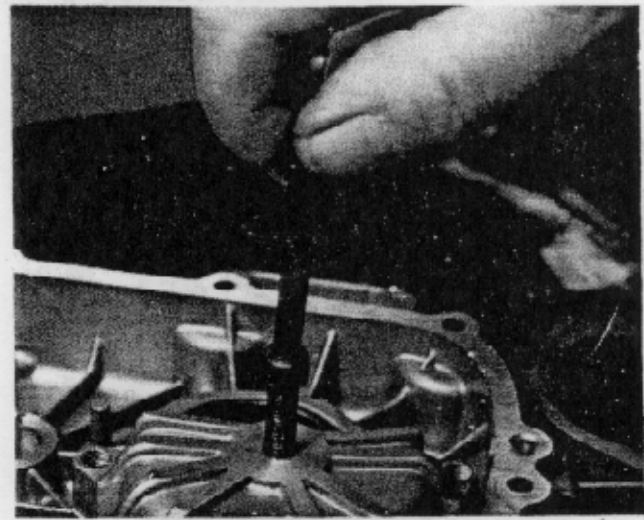

3.3.1.20-Install a bolt into the threaded hole at top of counterbalance cover. Tighten bolt against counterbalance shaft until cover is free of shaft, then remove cover.

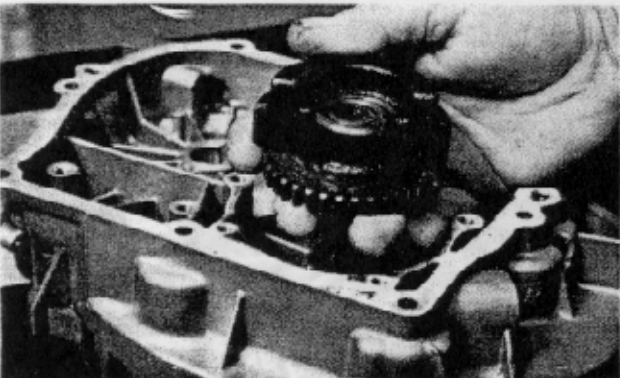

3.3.1.21-Remove counterbalance assembly.



3.3.1.22-Shim washers are used at bearing cover end of crankshaft to establish crankshaft end play. Check number of shims - during re-assembly, the same number of shims must be used.

3.3.2- INSPECTION AND REPAIR

3.3.2.1-CYLINDER BLOCK

Replace cylinder block if:-

- a.)-Fins are broken or cracked
- b.)-Head mounting surface is warped
- c.)-Cylinder inner diameter is greater than 0.5 mm oversize.

If cylinder is to be rebored, first determine whether to bore 0.25 mm or 0.50 mm oversize. Use any standard commercial hone of a suitable size. Chuck the hone in a drill press having about a 600 rpm speed. Use standard boring procedures.

Valve seats require grinding only if pitted or scored. If seats are not pitted or scored, lapping will provide a satisfactory valve seat. Valves must be lapped to seats when seats are reground.

3.3.2.2-ENGINE GEAR COVER

Clean and degrease engine gear cover. Replace if cracked, warped, or damaged.

3.3.2.3- CAMSHAFT

Clean camshaft in non-flammable solvent and blow dry. Replace a camshaft that shows signs of wear or scoring. If a damaged camshaft gear is replaced, also replace the mating crankshaft gear. If keyways are damaged or worn, replace camshaft. Inspect keys, replace any that are damaged or worn excessively. Replace flyweight or governor shaft if damaged.

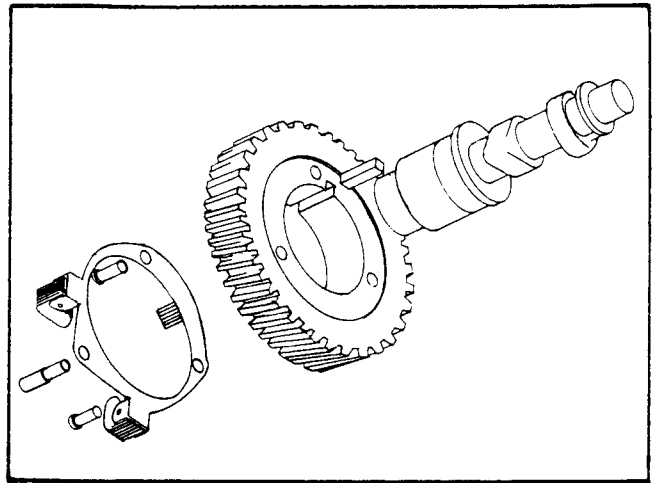

3.3.2.4-CRANK SHAFT

Replace crankshaft if:-

- a.)- Damaged threads can't be dressed
- b.)- Bearing surfaces are worn, scratched or damaged
- c.)- Flat spots have developed
- d.)- Crankshaft is bent - NEVER TRY TO STRAIGHTEN A BENT CRANKSHAFT
- e.)- Crankpin is out-of-round more than 0.002 inch

When installing a crankshaft, always lubricate bearing surfaces. If the camshaft drive gear on crankshaft is replaced, replace the mating camshaft gear as well. The crankshaft must be shimmed during assembly to establish an end play of 0.0039 to 0.0118 inch.

3.3.2.5- PISTON

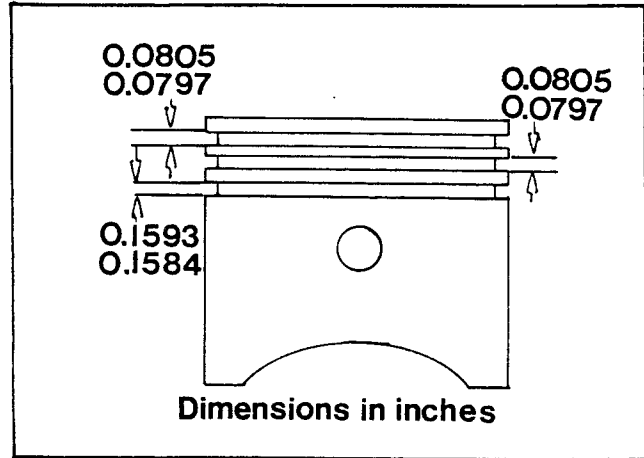
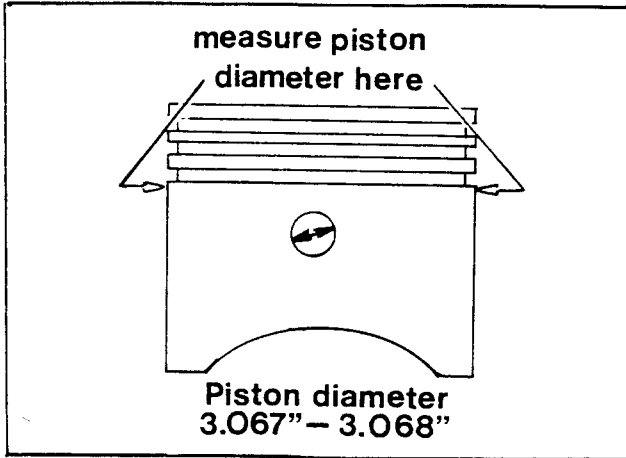

Clean carbon from piston ring grooves, as well as from upper cylinder bore and head. Check piston dimensions, as shown above. Replacement pistons are available in 3 sizes - standard, 0.25 mm oversize and 0.50 mm oversize.

Check for proper width of compression and oil ring grooves on piston. See illustration above.

3.3.2.6- RINGS

Replace rings in sets. During installation ring gaps must be staggered. Before installing new rings, deglaze cylinder walls thoroughly with fine emery cloth and clean thoroughly. Rings are available in standard size, as well as oversize to match the oversize pistons that are available.

Check for proper clearance of compression and oil control rings in piston grooves. See illustration at right.

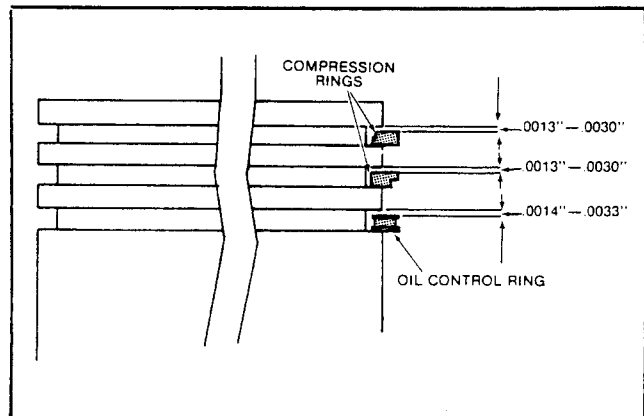

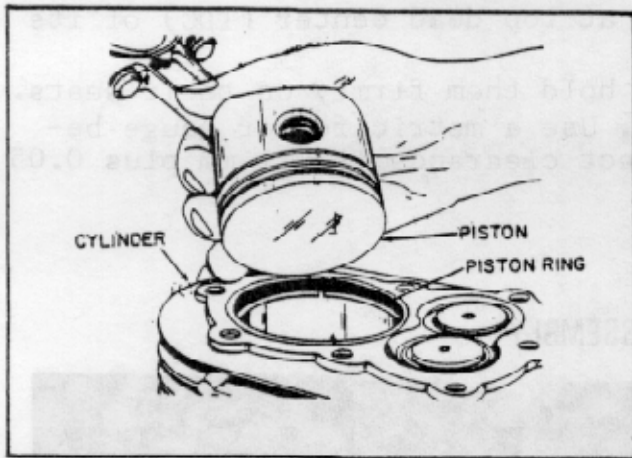

Check ring gaps on worn rings to determine if rings should be replaced. Check gaps on new rings to determine if cylinder should be rebored. To check ring gap, square the ring in the cylinder bore as shown above.

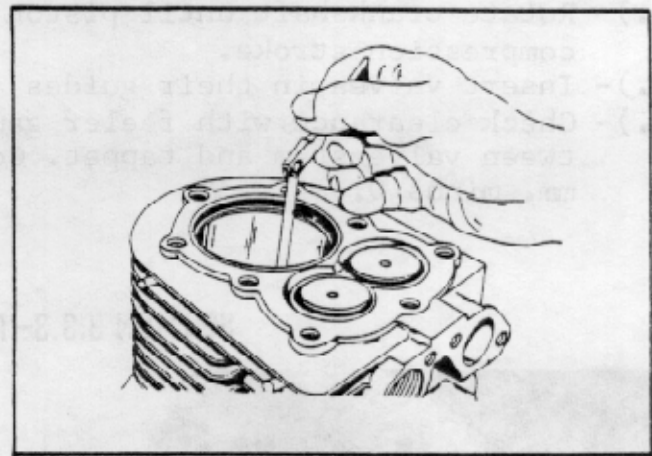

After squaring the ring in bore, use feeler gauge to check ring gap.

3.3.2.7- VALVES

Intake and exhaust valves are NOT identical - intake valves are identified by the letter "I", exhaust valves by an "E".

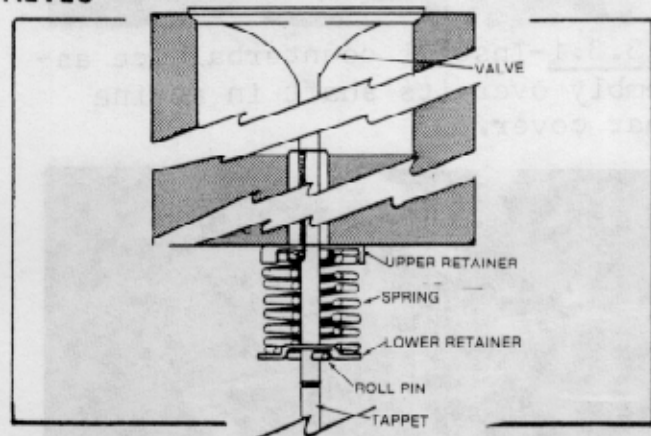

Clean valve parts in non-flammable solvent. Remove carbon from valves. Replace distorted or damaged valves. If valves are useable, they may be ground to a 45 degree angle. When new or re-ground valves are to be installed, lap them to ensue a gas tight fit. Lap valves as follows:-

1. Coat valve face sparingly with a fine grade of valve grinding compound.
2. Rotate valve on valve seat. Lift valve from seat every 8 - 10 strokes to keep compound equalized on surface of valve seat.
3. Continue lapping until both the valve and seat has a smooth surface. Clean thoroughly to remove all traces of lapping compound. Dry thoroughly.

To obtain correct valve tappet clearance, grind ends of valve stems off squarely. Use a V-block to hold valve stem square to grinding wheel. After grinding, check for proper clearance as follows:-

- 1.)- Rotate crankshaft until piston is at top dead center (TDC) of its compression stroke.
- 2.)- Insert valves in their guides and hold them firmly on their seats.
- 3.)- Check clearance with feeler gauge. Use a metric feeler gauge between valve stem and tappet. Correct clearance is 0.1 mm plus 0.05 mm, minus 0.

SECTION 3.3.3- REASSEMBLY



3.3.3.1-Install counterbalance assembly over its shaft in engine gear cover.

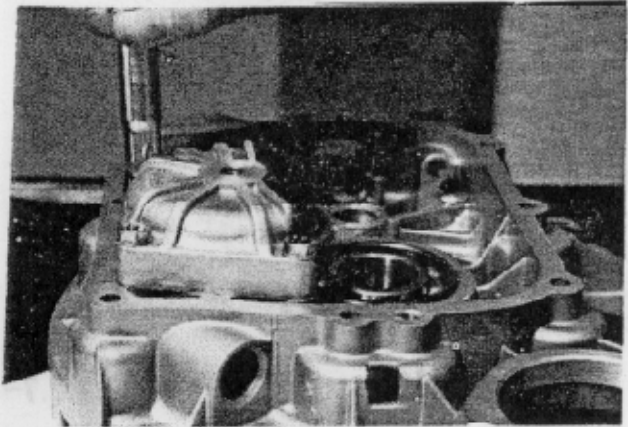

3.3.3.2-Install counterbalance cover. Retain with 4 bolts and lockwashers. Tighten bolts to 90-110 inch-pounds.

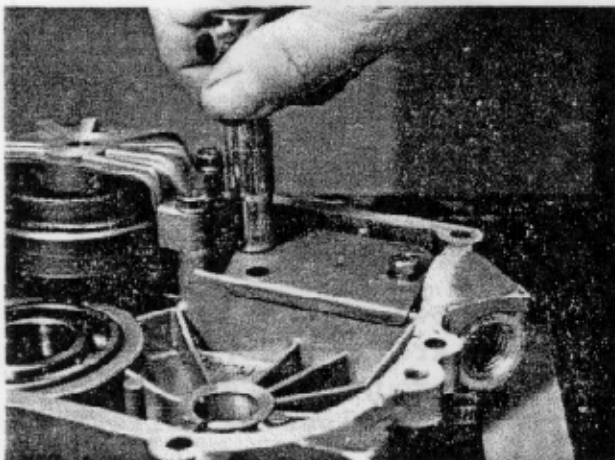

3.3.3.3-Install oil stopper into gear cover. Tighten bolts to 90-110 inch-pounds.

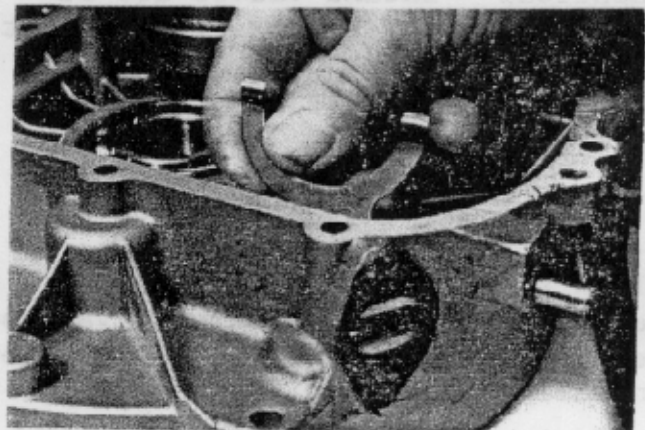

3.3.3.4-Install governor shaft assembly. Retain with spring clip.

3.3.3.5-Install oil stopper into cylinder block. Tighten bolts to 90-110 inch-pounds.



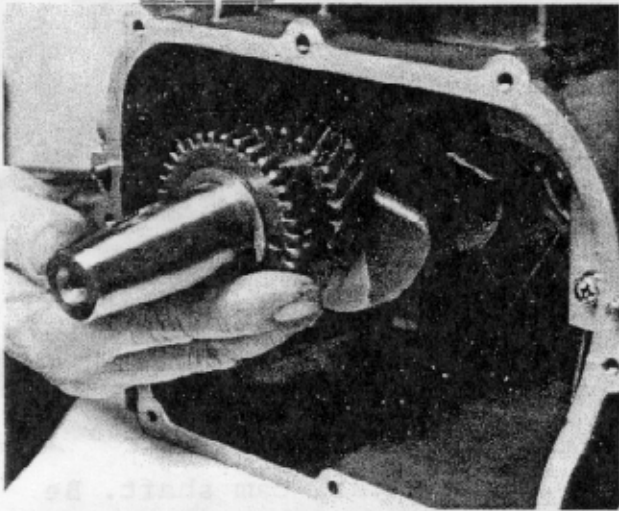

3.3.3.6-Install crankshaft end play shims. Install crankshaft. Use care not to damage oil seal and bearing.

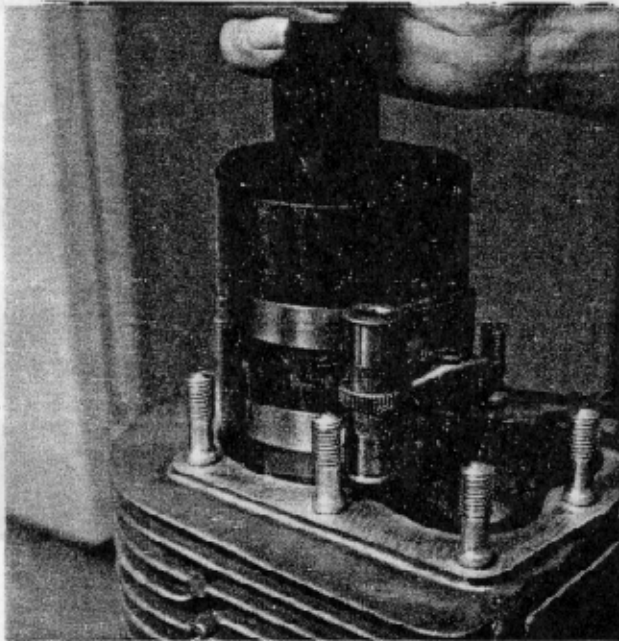

3.3.3.7-Install rings onto piston. Ring end gaps should be staggered. See Section 3.3.2, INSPECTION AND REPAIR, for proper ring locations in piston grooves. Slide connecting rod with piston installed down through cylinder until rings contact top of cylinder block. Then use ring compressor to compress rings into piston grooves. With rings compressed, tap piston into cylinder. While tapping, align connecting rod with crankshaft. When rings are engaged by cylinder, remove ring compressor.

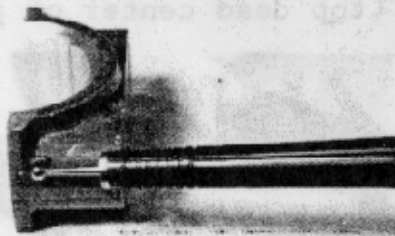

3.3.3.8-Connecting rod and connecting rod cap are a matched set and must be replaced as a set. Mark on cap (see above) must align with identical mark on connecting rod during installation.

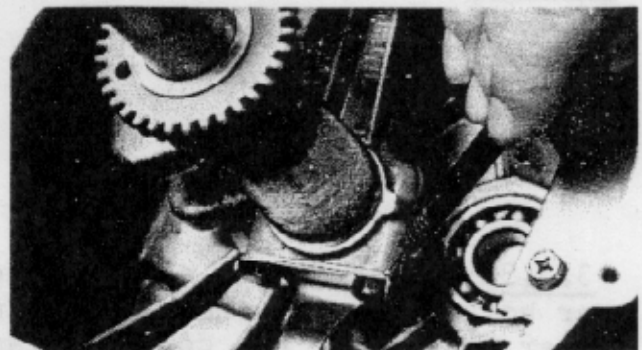

3.3.3.9-Lubricate bearing surfaces of connecting rod and cap. Install connecting rod cap, oil splasher, and lock tab onto connecting rod. Retain with connecting rod bolts. Use torque wrench and tighten bolts to 18 - 22 foot-pounds. Bend ends of lock tab over bolt heads.

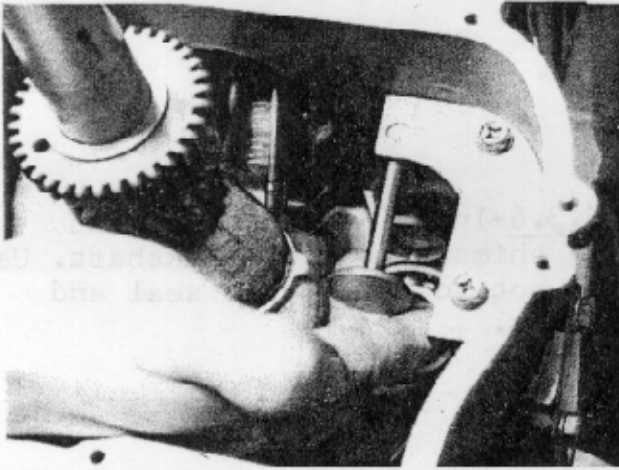

3.3.3.10-Install tappets.

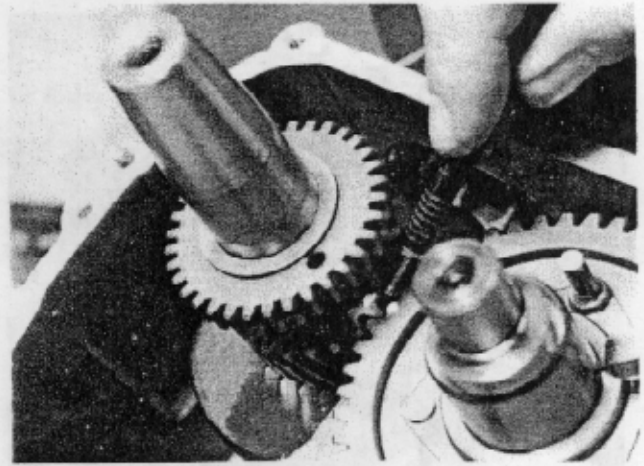

3.3.3.11-Install cam shaft. Be careful not to damage bearing and oil seal. Timing mark on valley of crankshaft gear must align with timing mark on tooth of camshaft gear.

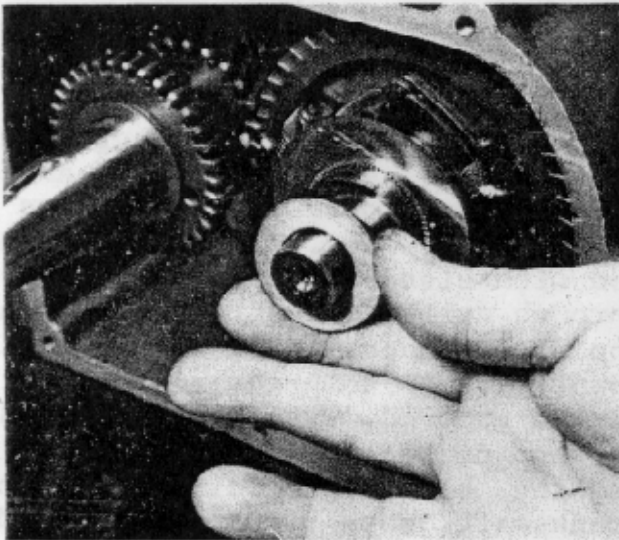

3.3.3.12-Install thrust washer over end of camshaft.

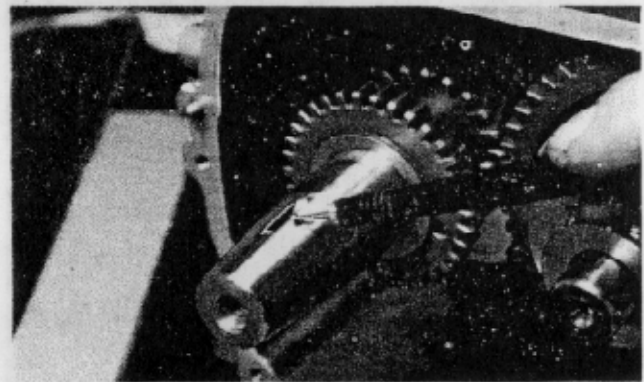

3.3.3.13-Before the engine gear cover can be installed, crankshaft must be turned to place its keyway at 12:00 position (top dead center of piston).

3.3.3.14-Install one of the longer bolts that retained the engine gear cover into the counterbalance alignment hole in gear cover. Rotate counterbalance while threading bolt into alignment hole. When bolt engages hole in counterbalance and counterbalance will not rotate, tighten bolt no further.

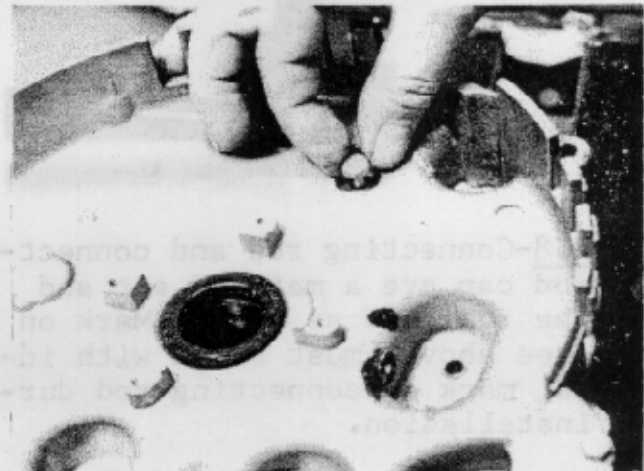

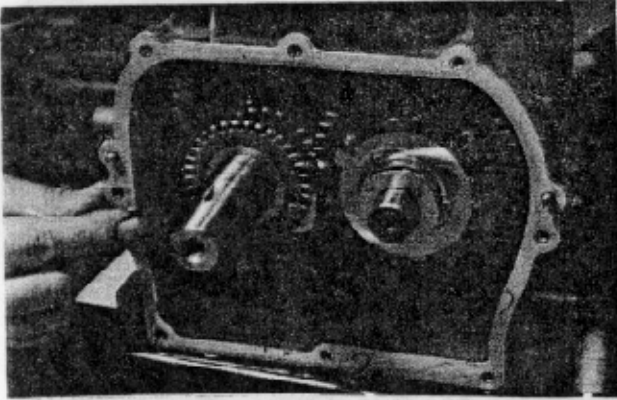

3.3.3.15-Install a new gear cover gasket.

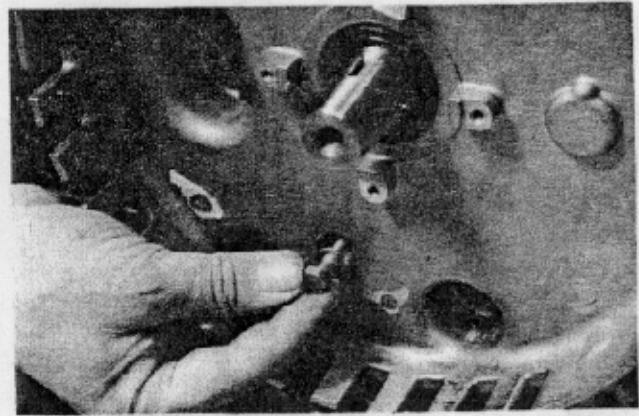

3.3.3.16-Align dowel pin on cylinder block with dowel pin hole on engine gear cover. Install gear cover. When cover is flush against cylinder block, remove bolt from counterbalance alignment hole.

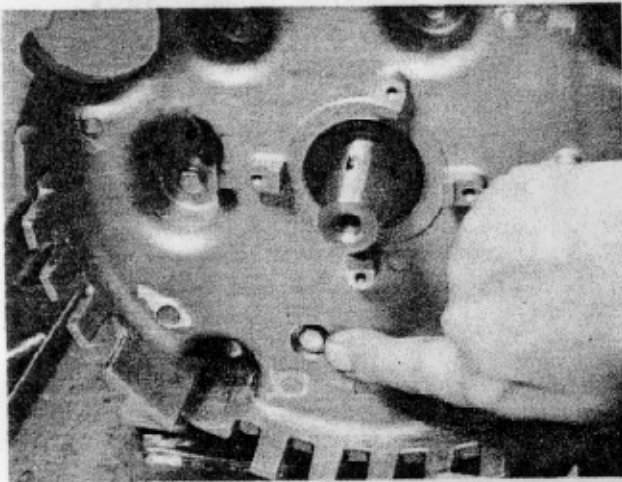

3.3.3.17-Install the correct bolt and flat washer into counterbalance alignment hole. USE THE CORRECT BOLT - if bolt is too long, damage to counterbalance will result.

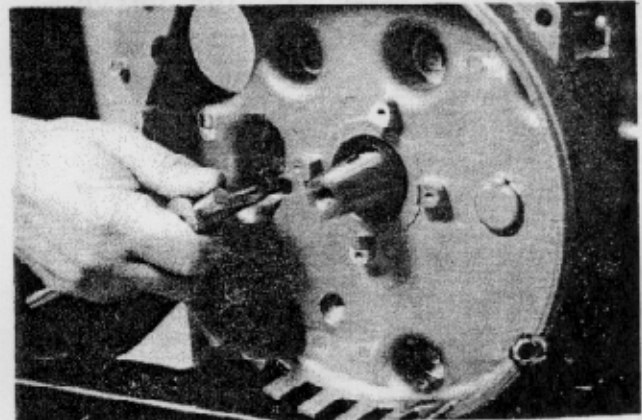

3.3.3.18-Retain engine gear cover to cylinder block with bolts and lockwashers. Tighten all bolts to 90-110 inch-pounds.

3.3.3.19-Install upper and lower valve spring retainers over ends of valve springs. Keep intake and exhaust valve parts together as a set. See illustration for correct retainer locations.

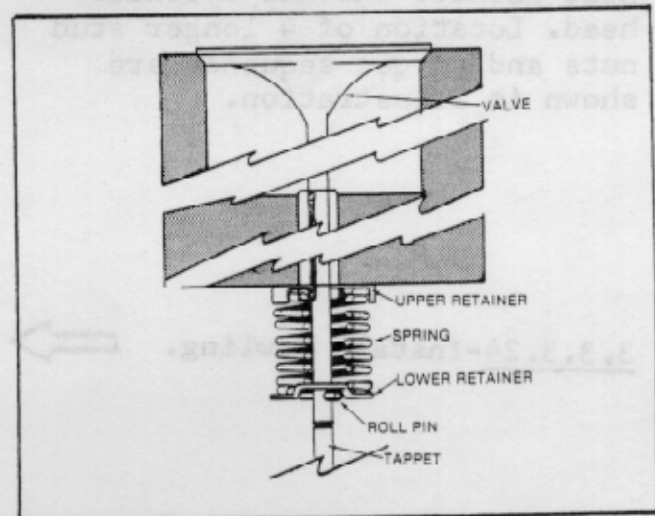

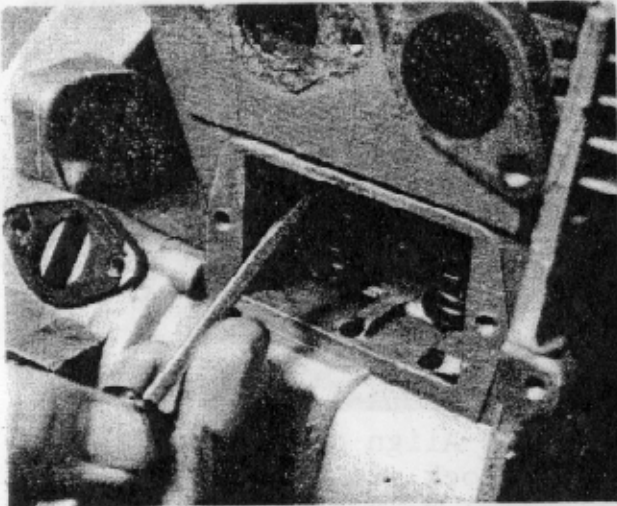

3.3.3.20-Install springs and retainers over tappets. Intake valve is identified by the letter "I", exhaust valve by an "E". Slide both valves down through valve guides, retainers and springs.

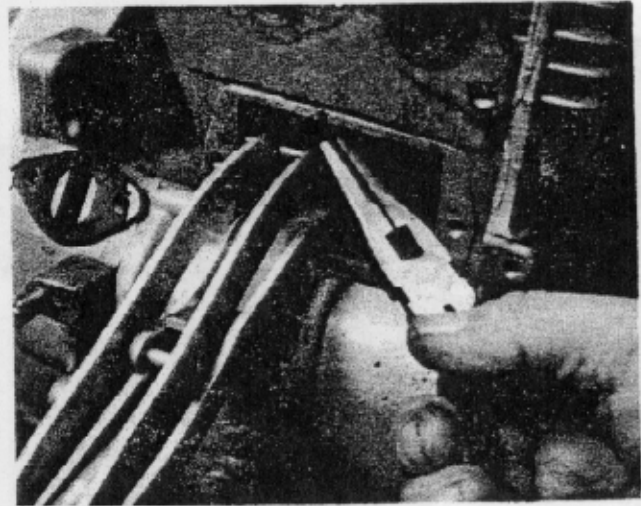

3.3.3.21-Compress valve springs, using a spring compressor. Then install roll pin through hole in valve stem. Remove compressor and make sure roll pin is locked in place by lower valve spring retainer.

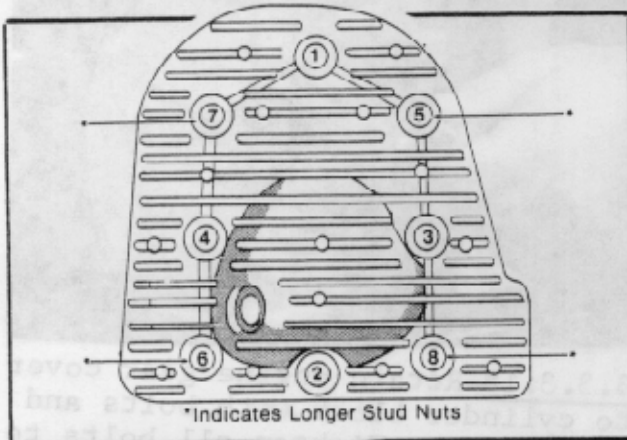

3.3.3.22-Install a new cylinder head gasket. Install cylinder head. Location of 4 longer stud nuts and torque sequence are shown in illustration.

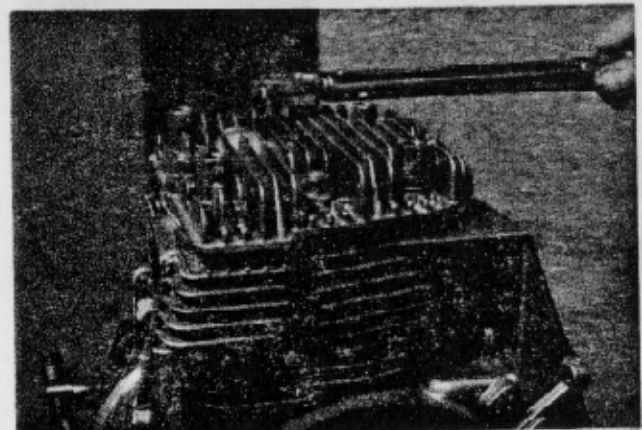

3.3.3.23-Tighten head nuts to 22-29 foot-pounds in sequence shown in previous illustration.

3.3.3.24-Install cowling. →

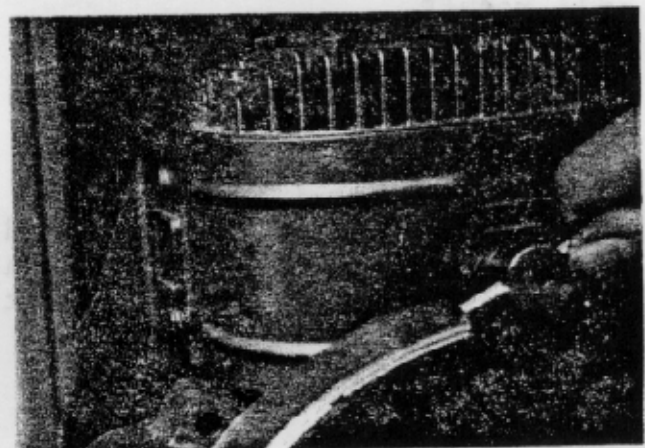

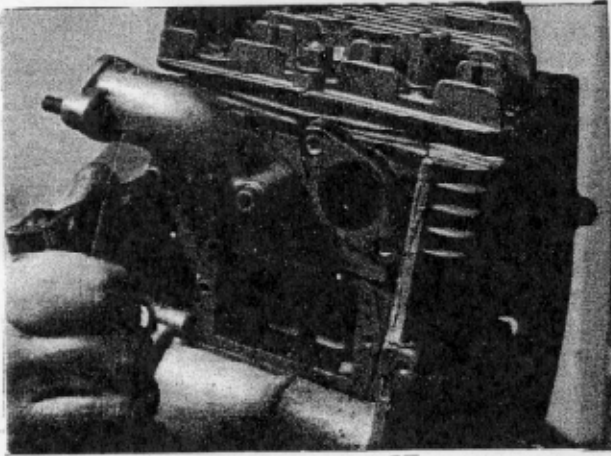

3.3.3.25-Install new intake manifold elbow gasket. Install intake manifold elbow.

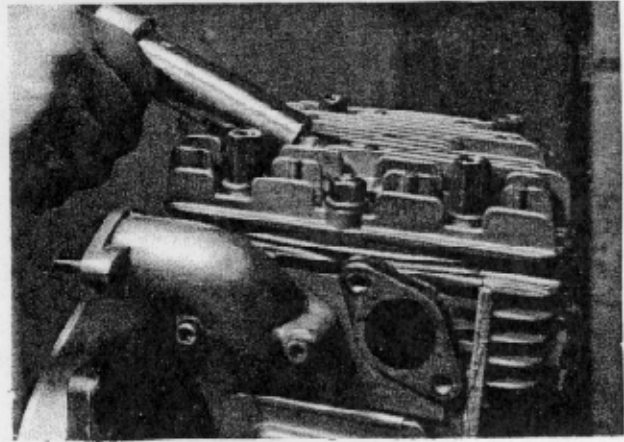

3.3.3.26-Install spark plug. Gap should be set to 0.035 inch. Torque spark plug to 18-22 foot-pounds.

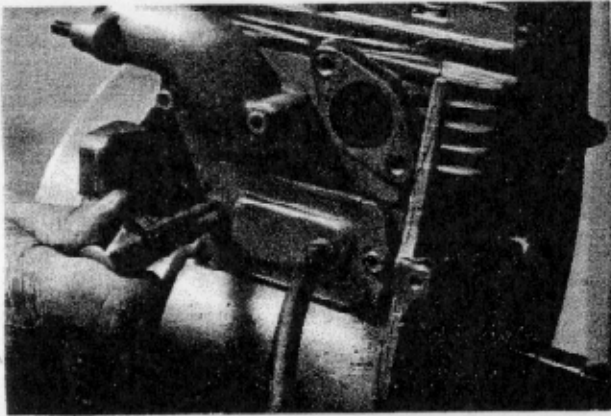

3.3.3.27-Install breather assembly. Tighten bolts to 90-110 inch-pounds.

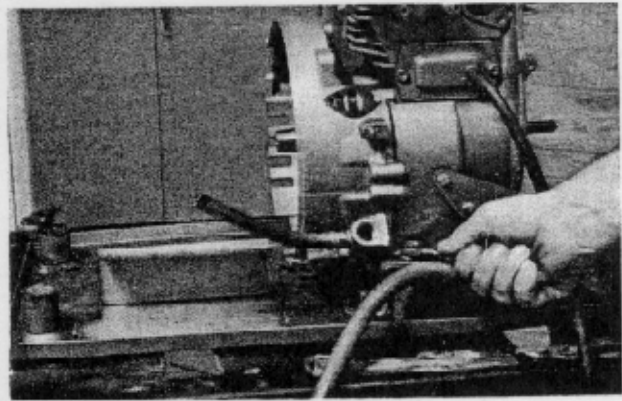

3.3.3.28-Install engine onto alternator slide pan.